

A ELEVATION - EMERGENCY ACCESS GATE @ VIA PRADO

SCALE: 1/2" = 1'-0"

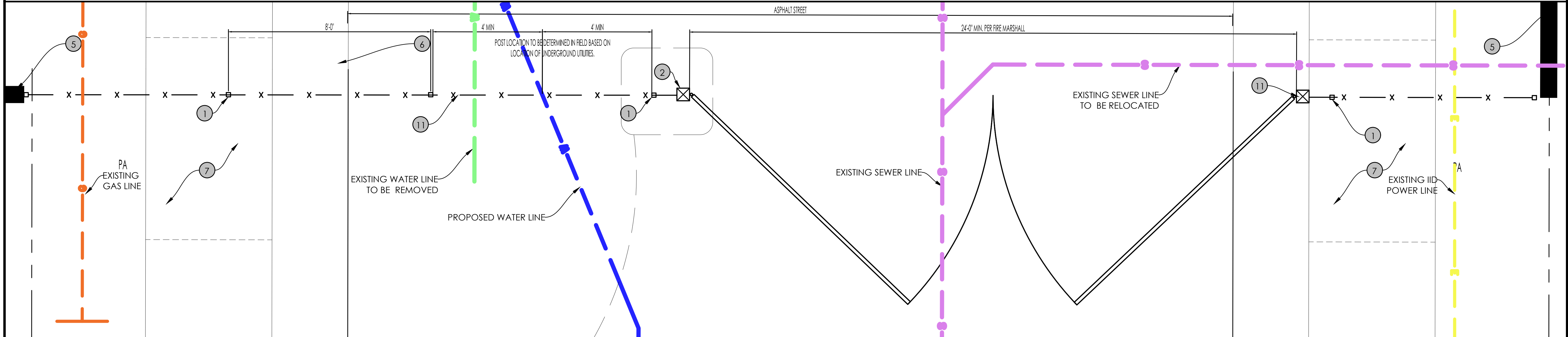

A.1 PLAN VIEW - EMERGENCY ACCESS GATE

SCALE: 1/2" = 1'-0"

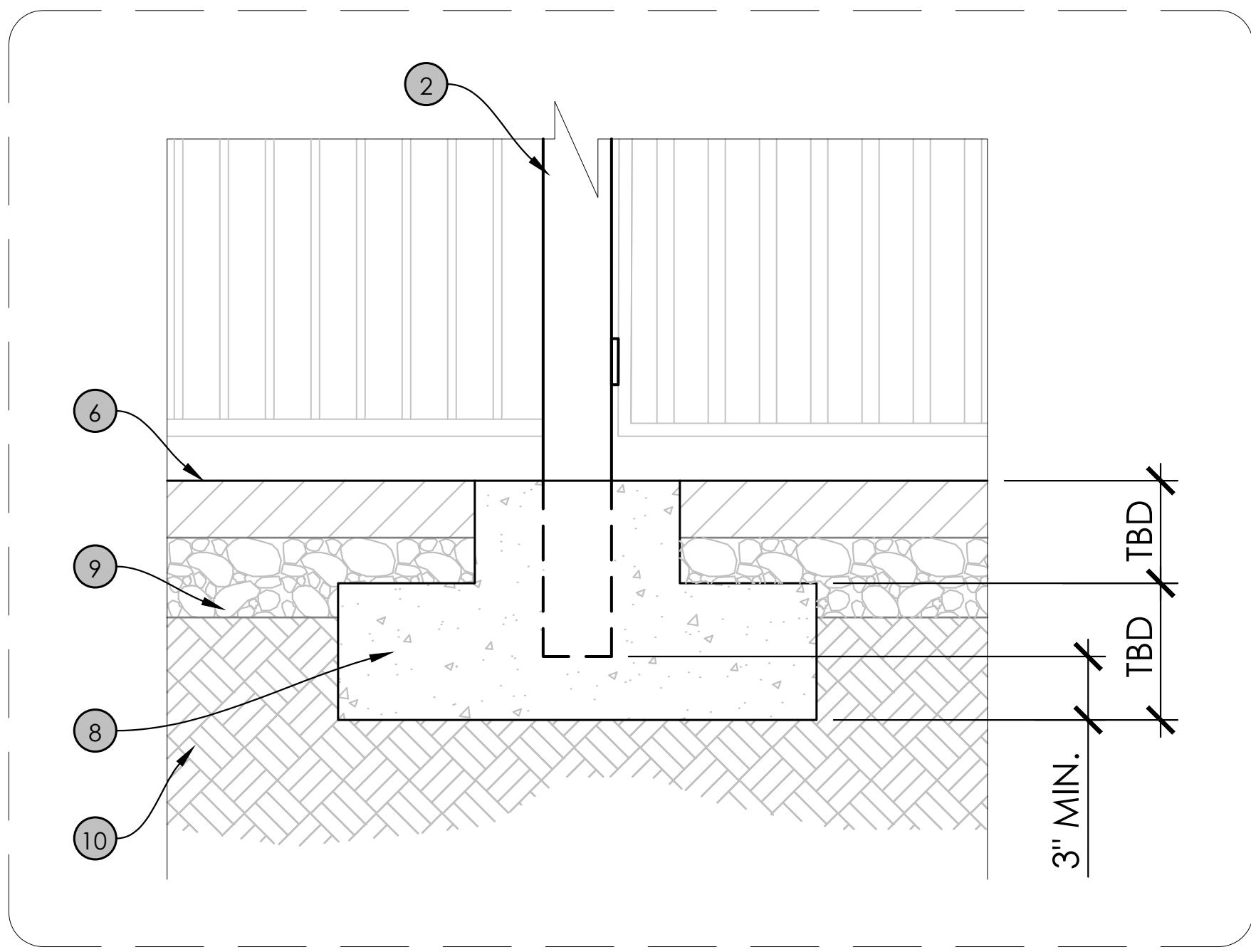

A.2 POST FOOTING ENLARGEMENT

SCALE: 1" = 1'-0"

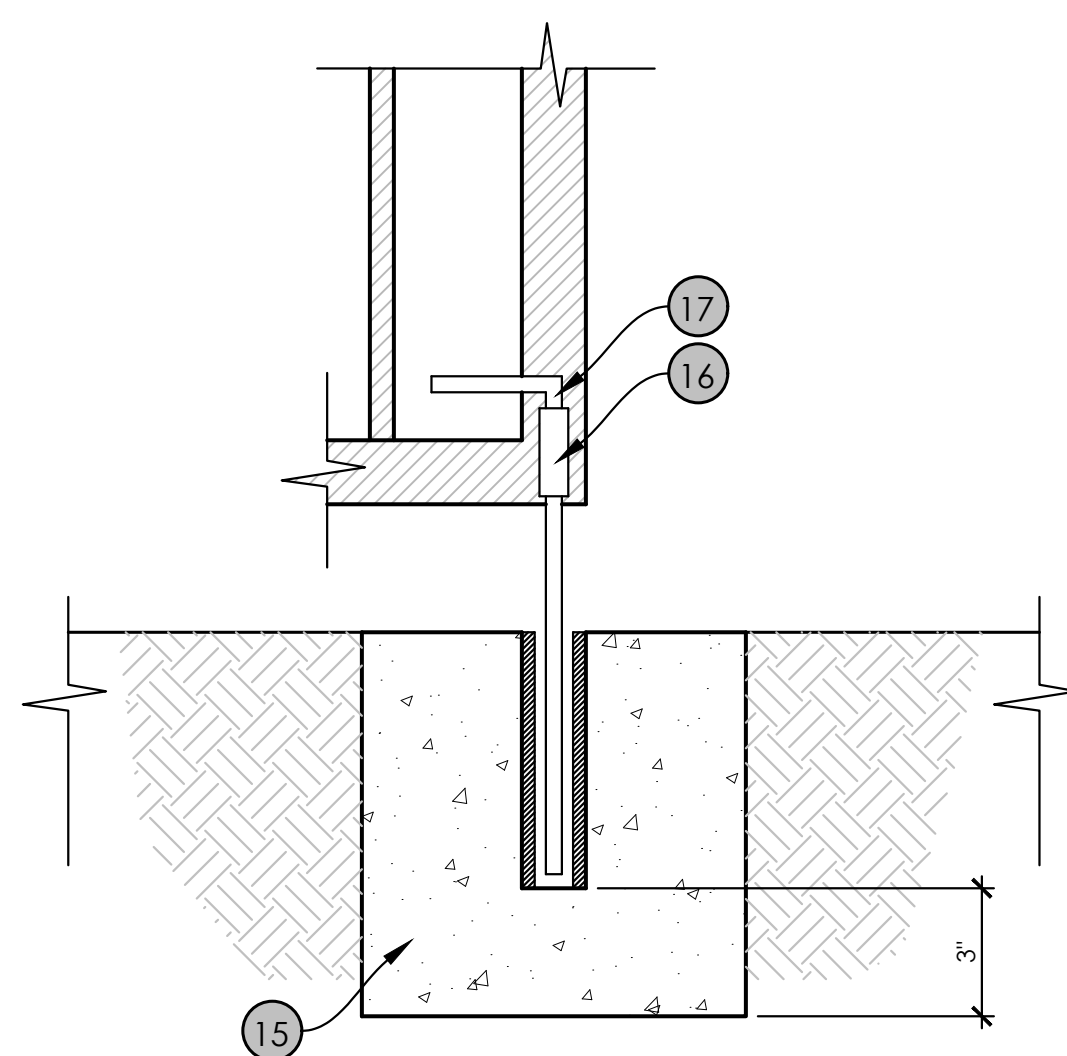

A.3 CANE BOLT ENLARGEMENT

SCALE: 1/2" = 1'-0"

KEYNOTES

- 1 2" FENCE POST
- 2 6" STEEL GATE POST IN ASPHALT
- 3 12" EMERGENCY GATES (24" MIN. WIDTH PER FIRE DEPT.)
- 4 PERFORATED METAL BY MCNICHOLS W/ 51% OPEN AREA
- 5 BLOCK WALL
- 6 ROLLING CURB
- 7 SIDEWALK
- 8 SPREAD FOOTING TO BE DESIGNED BY STRUCTURAL ENGINEER. ENGINEER TO COORDINATE WITH UTILITIES BELOW TO AVOID INSTALLATION CONFLICTS. TBD = TO BE DETERMINED BY STRUCTURAL ENGINEER.
- 9 ROAD BASE
- 10 COMPACTED SUBGRADE
- 11 FENCING
- 12 2" SQ TUBE STEEL FRAME
- 13 1/2" SQ TUBE STEEL PICKETS AT 4" O.C. WITH METAL MESH WELDED TO PROPERTY SIDE OF GATE.
- 14 CANE BOLT:
- 15 8" DIAMETER x 12" DEEP CONCRETE FOOTING
- 16 STEEL SLEEVE/RECEIVER FOR CANE BOLT
- 17 STEEL SLEEVE WELDED TO FRAME TO ACCEPT CANE BOLT

1. WELD ALL CONNECTIONS & GRIND SMOOTH. FINISH ALL METAL SURFACES W/1 COAT OF ZINC-CHROMATE PRIMER & 2 COATS OF EXTERIOR GRADE ENAMEL. CONTRACTOR TO SUBMIT SHOP DRAWINGS TO LANDSCAPE ARCHITECT FOR APPROVAL PRIOR TO FABRICATION.
 2. FENCE COLOR TO MATCH ADJACENT BLOCK WALL

CONSTRUCTION DETAILS

COACHELLA 107
 COACHELLA, CA

SHEET TITLE

PROJECT:

LANDSCAPE ARCHITECT:



PROJECT MANAGER:	TM
DRAWN:	EB
CHECKED:	TM
PROJ. NO.	2629
DATE:	4/19/21
SCALE:	PER DETAIL
REVISIONS:	INIT.
△ -	-
△ -	-
△ -	-
△ -	-
△ -	-
△ -	-
△ -	-
△ -	-
△ -	-

SHEET NO:

L-2.00

KEYNOTES

- 1 2" SQ. STEEL POST @ 8'-0" O.C.
- 2 1 1/2" SQ. STEEL RAIL
- 3 3/4" SQ. STEEL PICKET @ 4 1/2" O.C.
- 4 PERFORATED METAL BY MCNICHOLS W/ 51% OPEN A
- 5 BLOCK WALL
- 6 SIDEWALK

1. WELD ALL CONNECTIONS & GRIND SMOOTH. FINISH ALL METAL SURFACES W/1 COAT OF ZINC-CHROMATE PRIMER & 2 COATS OF EXTERIOR GRADE ENAMEL. CONTRACTOR TO SUBMIT SHOP DRAWINGS TO LANDSCAPE ARCHITECT FOR APPROVAL PRIOR TO FABRICATION.
 2. FENCE COLOR TO MATCH ADJACENT BLOCK WALL

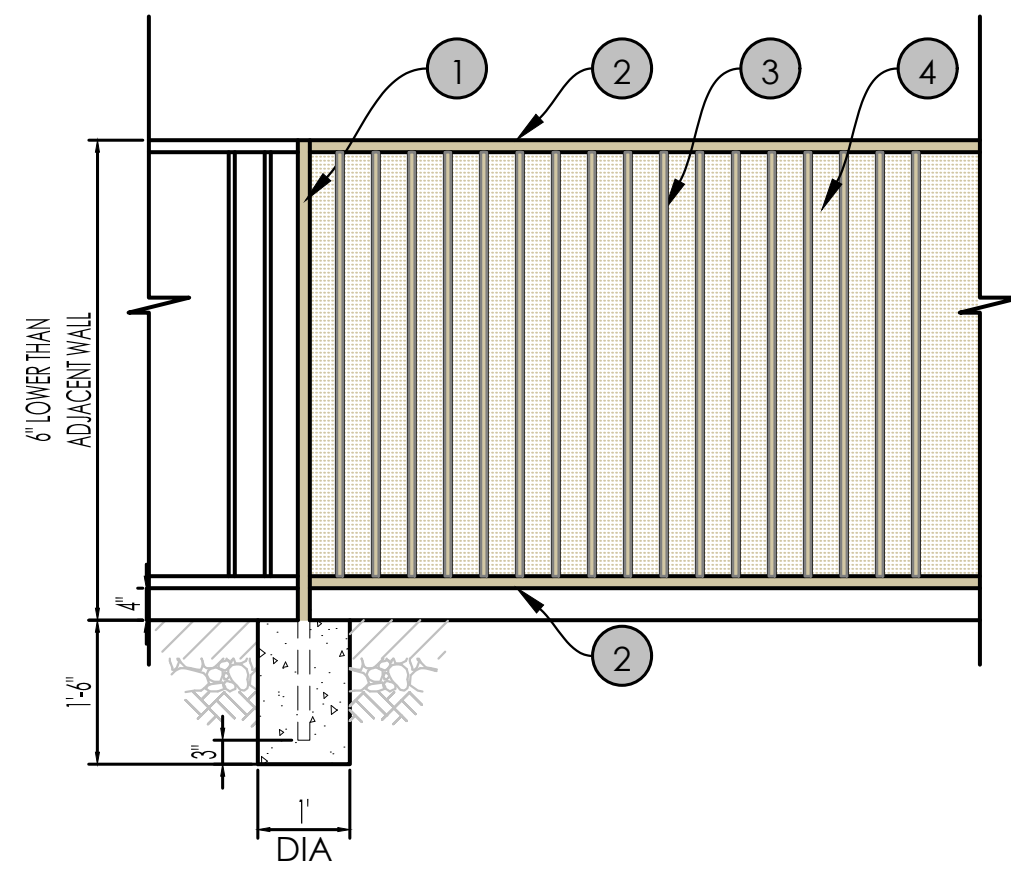

B ELEVATION - STEEL TUBE FENCE @ RIBERA STREET

SCALE: 1/2" = 1'-0"

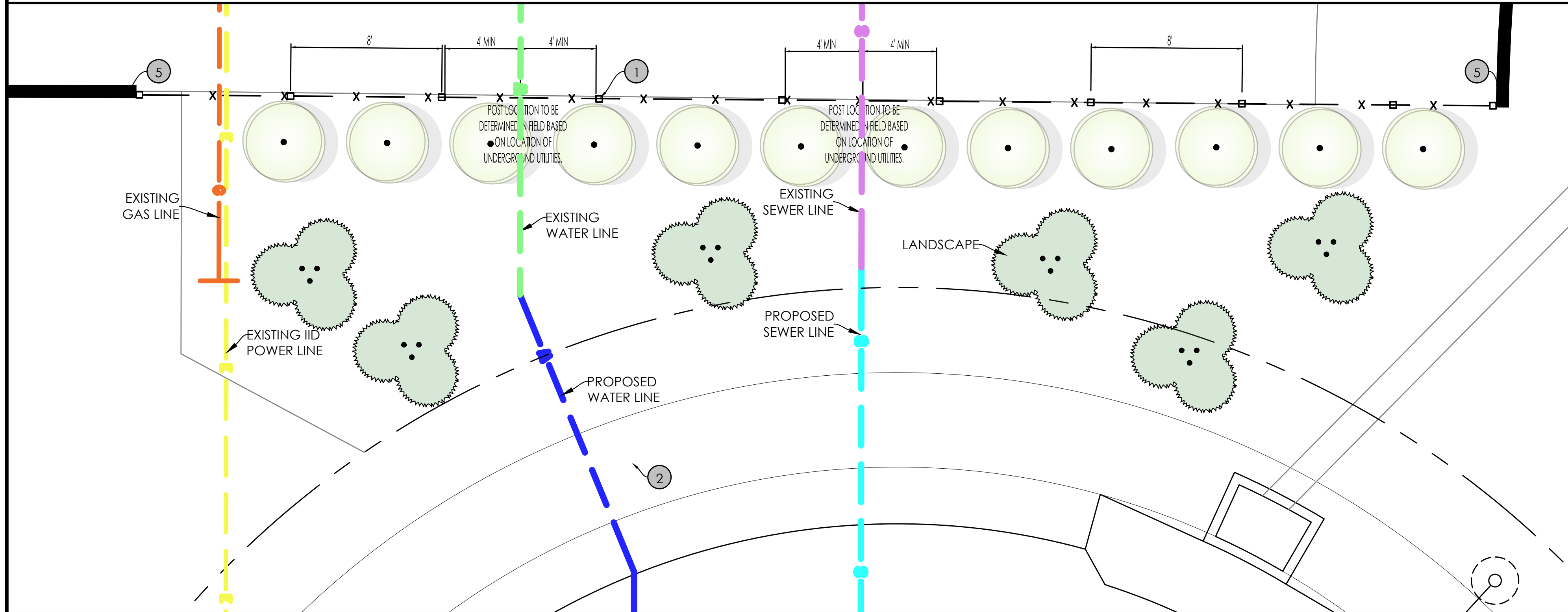

B.1 PLAN VIEW - GATE

SCALE: 1/4" = 1'-0"

CONSTRUCTION DETAILS

COACHELLA 107
 COACHELLA, CA

SHEET TITLE

PROJECT:

LANDSCAPE ARCHITECT:



PROJECT MANAGER: TM

DRAWN: EB

CHECKED: TM

PROJ. NO. 2629

DATE: 4/19/21

SCALE: PER DETAIL

REVISIONS:

NO.	DESCRIPTION	INIT.
1		
2		
3		
4		
5		
6		
7		
8		
9		
10		

SHEET NO:

L-2.01