

**COVALDA
APARTMENTS SIGN
PROGRAM**

51392 Cesar Chavez Street,
Coachella CA 92236

FEB 5, 2024

Refined Signs & Mailboxes

Lic#941692

1980 Peacock Blvd. Suite B

Oceanside, Ca 92056

LANDLORD: TRIPOLI CIC, LP
 6339 PASEO DEL LAGO
 CARLSBAD CA 92011
 760-456-6000

SIGN CONSULTANT: REFINED SIGNS
 1980 PEACOCK BLVD, SUITE B
 OCEANSIDE CA 92056

TABLE OF CONTENTS

DESIGN GUIDELINES1

CONSTRUCTION REQUIREMENTS4

EXHIBITS6

PROJECT SIGN CRITERIA 7

 PROJECT SITE PLAN 8

 BUILDING A FRONTAGE AND ELEVATIONS10

 BUILDING B FRONTAGE AND ELEVATION11

 SECONDARY SITE SIGNAGE13

RETAIL TENANT SIGN CRITERIA 14

 RETAIL TENANT IDENTIFICATION SIGNS15

 RETAIL TENANT WINDOW SIGNS20

 ANCILLARY SIGNS21

 TEMPORARY SIGNAGE22

REQUIRED SUBMITTALS AND APPROVALS 23

INTRODUCTION

The objective of the Sign Program for Tripoli Apartments is to provide comprehensive design standards and specifications that assure consistency in quality, color, size, placement, and configuration for signage and to provide for project identification and retail tenant identification.

DESIGN GUIDELINES

A. Acceptable Sign Treatments

Only those sign types specified in the Sign Program and/or specifically approved in writing by the Owner and the City will be allowed. Sizes and quantities for signs shall be as outlined in the criteria and exhibits for each sign type. See details for each sign type below.

A strong connection shall be maintained between all signage and the project architecture. Elements of color, materials, scale, form and detail shall be reflected in the signage. Signs shall fit comfortably, never crowding the architectural or landscaping elements in immediate vicinity.

B. Lighting

1. Wall signs may be illuminated by providing back-lighting behind individually mounted letters and symbols (halo-lit). Blade Signs are externally illuminated with incorporated spot lights. Lighting shall be directed and shielded to illuminate the sign and not to spill over to other parts of the building or site.
2. All electrical housings and posts for signs shall be painted to match the building background immediately behind and adjacent to the sign.
3. Internally illuminated box signs (where the entire sign backgrounds are illuminated) are prohibited.

C. Colors

Sign colors shall be designed to provide sufficient contrast against background colors. Nationally recognized retail tenants may use their corporate colors subject to Owner's and City's prior written approval.

D. Copy / Typestyles

1. Copy and layout are subject to Owner's prior written approval.

DI. Sizes and Quantities

Sizes and quantities for signs shall be as outlined in the criteria for each sign type. Notwithstanding the maximum square footage specified for copy area allowances, adequate amounts of visual open space shall be provided so that signs appear balanced and in scale in relation to their backgrounds and adjacent signage.

1. Sign area shall be calculated as follows:

Sign Area: The area of that triangle, square, or polygon formed on a plane from the least number of straight lines (not to exceed eight in number) all parts of which are measured at least six (6) inches from, and enclosing, all writing, trade-marks, illustrations, backing lighting and those backing structures except building walls and monument base, columns or architectural supports.

Individual letters: The area of wall or window signs composed of individual letters is considered to be the area within the single continuous perimeter encompassed by a straight-line geometric figure which encloses the extreme limits of the letters or other characters.

DII. Prohibited Signs

1. Any sign not in accordance with this Sign Program and the Specific Plan.
2. Abandoned signs
3. Rotating, revolving, flashing, animated, blinking, gyrating or moving signs.
4. Vehicles, trailers or other signs or devices when used exclusively or primarily as advertising devices or displays.
5. Off-premise signs (other than directional signs) installed for the purpose of advertising a project, event, person or subject not related to the premises upon which said sign is located.
6. Signs that create a safety hazard or resemble or conflict with any traffic control device.
7. Flags, pennants, streamers, spinners, festoons, windsocks, valances or similar displays without prior approval by the Owner and City.
8. Balloons or other inflatable devices.
9. Roof signs
10. Signs promoting immoral or unlawful activities.

11. Billboards or Outdoor Advertising devices and advertising displays.
12. Freestanding "A" frame signs or "human" signs.
13. Internally illuminated box signs (signs where the sign backgrounds are illuminated).
14. Face lit channel letters.
15. Any signs not addressed in this sign plan and specifically prohibited by City of Coachella Zoning and Signage Regulations.

G. Owner's Right to Enforce

The Owner may, at its sole discretion and at the violator's cost, correct, replace or remove any sign that is installed without written approval and/or that is deemed not to be in conformance with the Sign Program, the plans as approved by the Owner, or erected without appropriate governmental agency approval or permits.

H. Abandoned Signs

An abandoned sign is that whose use is discontinued because the premises upon which it is located becomes vacated and unoccupied for a period of more than 30 days. The Owner may, at its sole discretion and at the violator's cost, replace or remove any abandoned sign.

I. Logos

All references to logos are registered trademark logos.

CONSTRUCTION REQUIREMENTS

The following requirements shall be observed:

A. Materials

1. Signs must be made of durable, rust-inhibited materials that are appropriate and complementary to the building architecture. All materials must be new.
2. All ferrous and non-ferrous metals shall be separated with non-conductive gaskets and stainless steel fasteners be used to secure ferrous to non-ferrous metals.
3. All bolts and fastenings shall consist of stainless steel, galvanized steel, anodized aluminum, brass or bronze; or carbon-bearing steel with painted finish. No black iron materials are allowed.

B. Processes and Installation

1. Joining of materials (e.g., seams) shall be finished in such a way as to be unnoticeable. Visible welds shall be continuous, smooth and filled. Rivets, screws, and other fasteners that extend to visible surfaces shall be flush, filled, and finished so as to be unnoticeable. Finished surfaces of metal shall be free from canning, warping and other imperfections.
2. Dimensional letters and plaques shall be affixed without visible means of attachment, unless attachments make an intentional design statement and are shown on approved shop drawings.
3. Penetrations into building walls, where required, shall be made waterproof, subject to Owner's review. Immediately upon abandonment or removal, building walls shall be restored at tenant's expense.
4. In no case shall any manufacturer's label be visible from the street or from normal viewing angles unless required on UL label.
5. Sign permit stickers shall be affixed to the bottom edge of signs, and only that portion of the permit sticker that is legally required to be visible shall be exposed.

6. All logo images and typestyles once approved by Owner, shall be accurately reproduced. Lettering that approximates intended typestyles shall not be acceptable.
7. Threaded rods or anchor bolts shall be used to mount sign letters which are spaced out from background panel or building wall. Angle clips attached to letter sides are not permitted.

C. Paint

1. Color coatings shall exactly match the colors specified on the approved plans. Surfaces with color mixes and hues prone to fading (e.g., pastels, fluorescent, complex mixtures, and intense reds, yellows and purples) shall be coated with ultraviolet-inhibiting clear coat in a matte, gloss, or semi-gloss finish. All finishes shall be free of dust, orange peel, drips, and runs and shall have a uniform surface.
2. All visible finishes shall be semigloss unless otherwise called out on shop drawings and approved by Owner.

EXHIBITS

Note: All maps and figures indicate typical design concepts and locations and are subject to change. Exhibits are not intended to suggest final sign designs or exact locations, depending on final site development and/or entry drive configuration.

PROJECT SIGN CRITERIA

COVALDA APARTMENTS SITE MAP



COVALDA APARTMENTS BUILDING A RETAIL FRONTAGE



COVALDA APARTMENTS BUILDING A RETAIL FRONTAGE

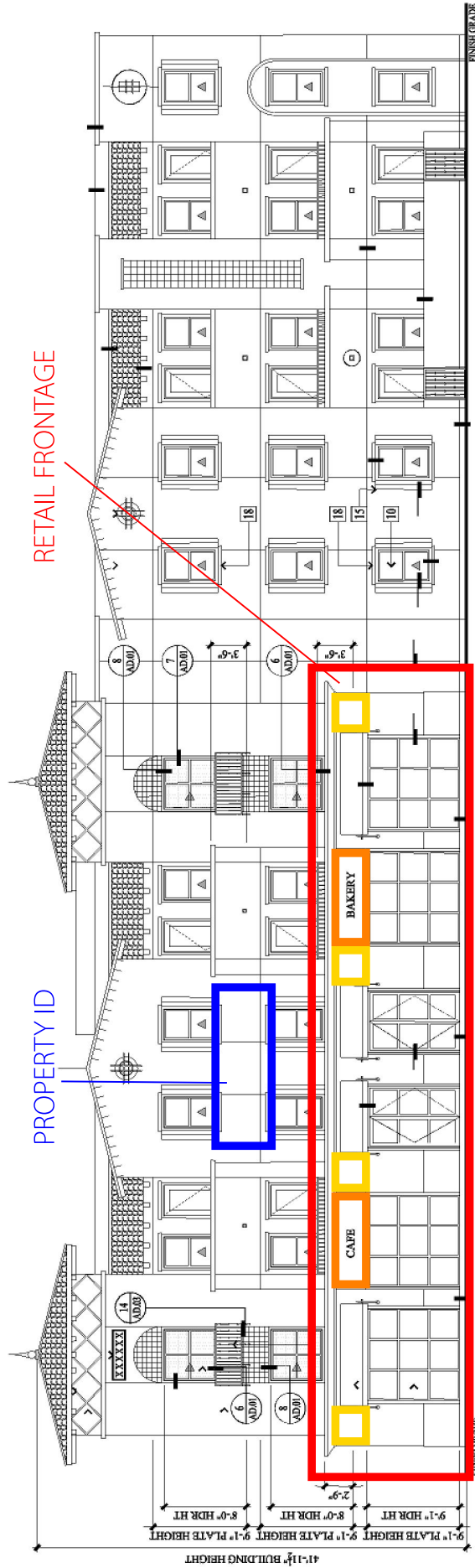

SIXTH STREET ELEVATION

YELLOW: POSSIBLE BLADE SIGN LOCATION
ORANGE: WALL SIGN LOCATION

COVALDA APARTMENTS BUILDING B RETAIL FRONTAGE

COVALDA SIGN PLAN

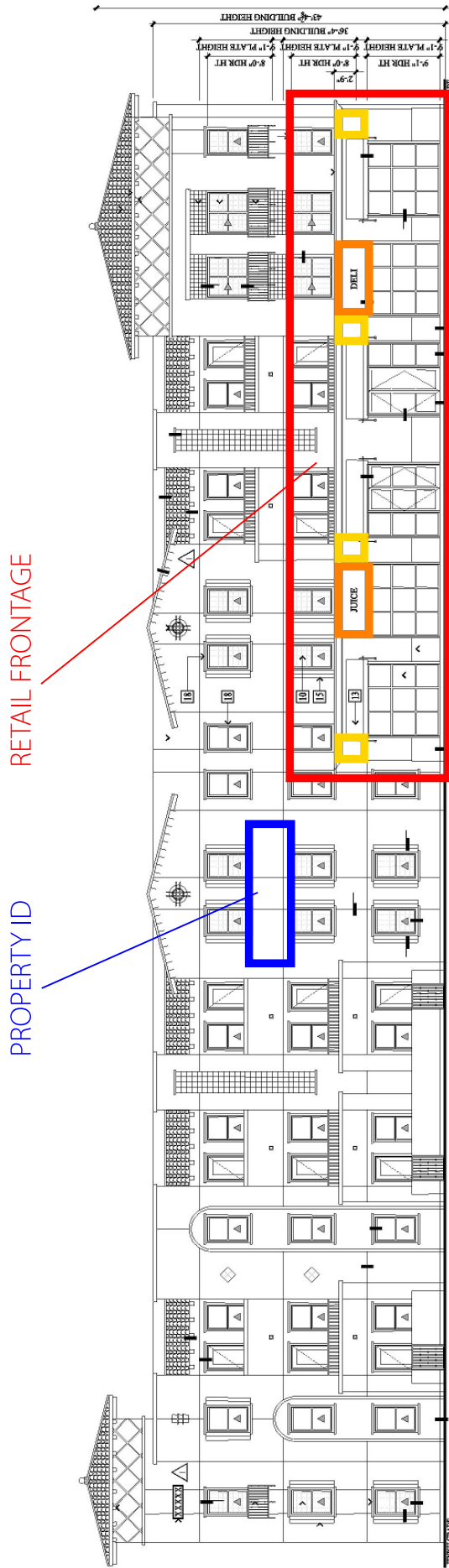

CESAR CHAVEZ AVENUE ELEVATION

YELLOW: POSSIBLE BLADE SIGN LOCATION
ORANGE: WALL SIGN LOCATION

SECONDARY SITE SIGNAGE

Secondary site signage are signs other than the primary project or tenant identification signs and may include:

- address signage
- suite number signs
- other code-required signs

The number and locations of secondary signs shall be subject to city review. Sizes shall not exceed allowances per city code.

RETAIL TENANT SIGN CRITERIA

SIGN TYPE (C) RETAIL TENANT IDENTIFICATION SIGN

QUANTITY	Each tenant occupying a Retail Suite in either Building A, or B shall be limited to a maximum of one (1) wall sign and one (1) blade sign.
LOCATION	May be located on the face of the tenant lease space wall, or projecting from the wall (blade sign), as appropriate.
COPY	Tenant names/ logo.
SIZE	Each tenant is allowed a total aggregate of 2 sq. ft per linear foot of tenant lease frontage, or 50 sq. ft. whichever is less, for all signs except window signs.
MATERIALS	Reverse channel letters; dimensional letters; or other materials compatible with building architecture.
COLORS	Bronze Lettering and Hardware. Custom colors with Owner approval, though Colors shall be compatible with the building architecture.
TYPE FACE	Custom tenant logotype/name with Owner approval.
LIGHTING	Halo lit letters. Externally illuminated Blade Sign.

SAMPLES OF SIGN SIZE/SHAPE FOR ILLUMINATED SIGNS

(NON-ILLUMINATED SIGNS DO NOT REQUIRE A SIGN BACKER)

ALL ILLUMINATED SIGNS MUST HAVE A DIMENSIONAL WEATHERPROOF SIGN BACKER
FABRICATED FROM ALUMINUM OR STAINLESS STEEL
WITH PAINT OR POWDERCOAT FINISH

ALL ELECTRICAL CONNECTIONS TO BE CONTAINED WITHIN WEATHERPROOF BACKER

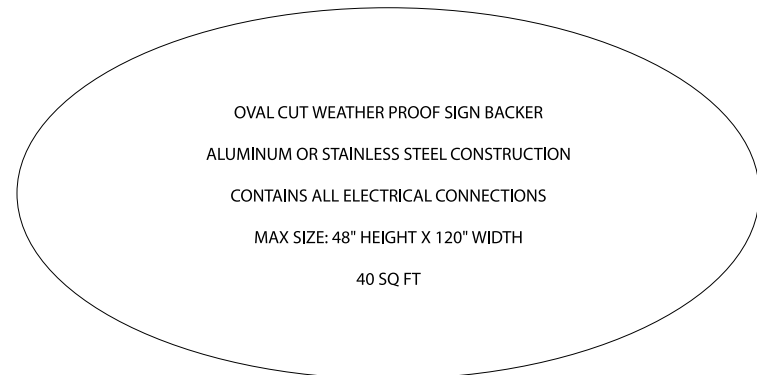
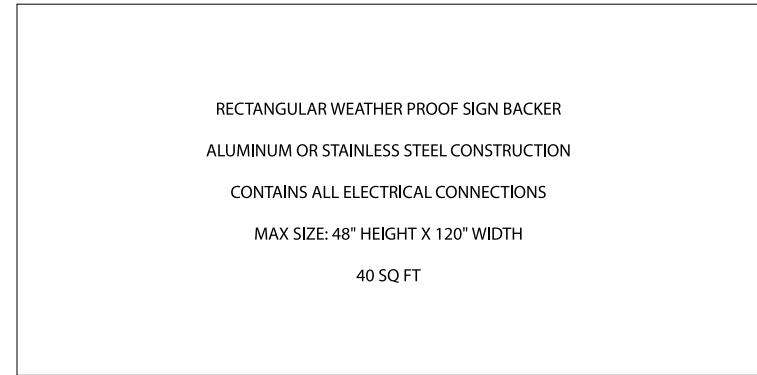

DIMENSIONAL WEATHERPROOF ALUMINUM SIGN BACKGROUND

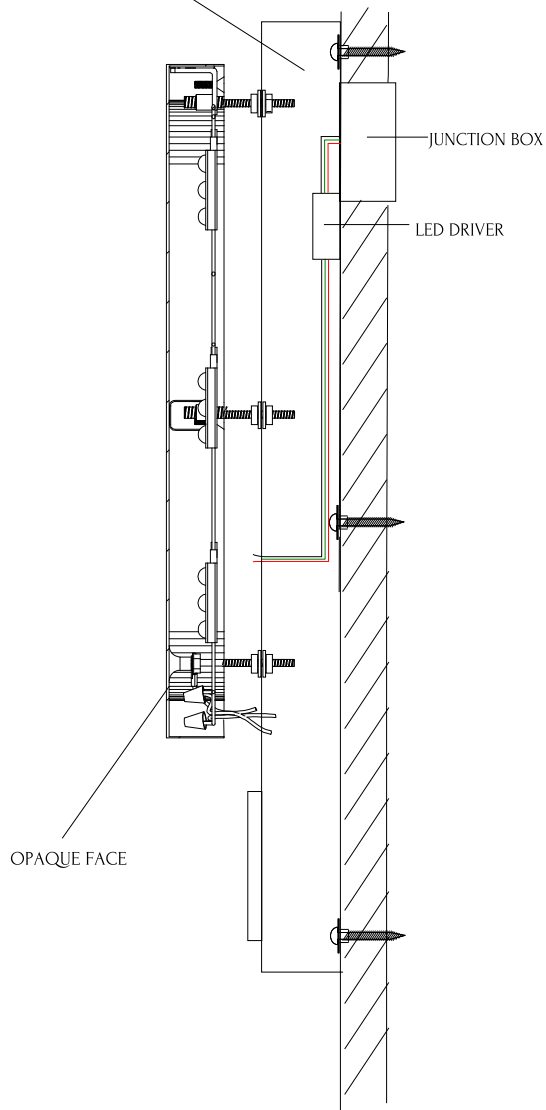

JUNCTION BOX

LED DRIVER

OPAQUE FACE

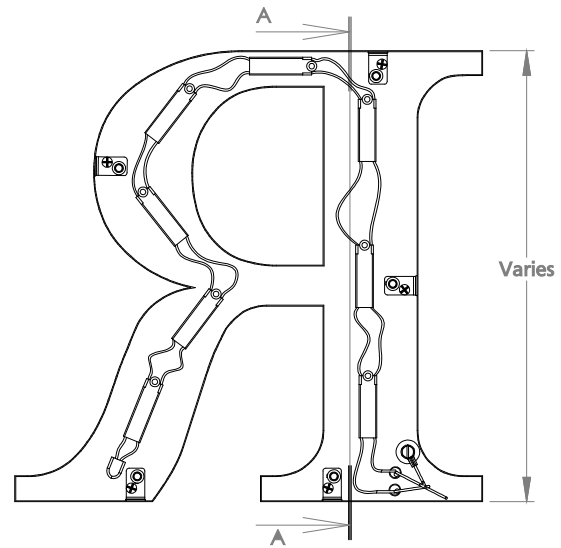

Varies

FRONT VIEW II SCALE

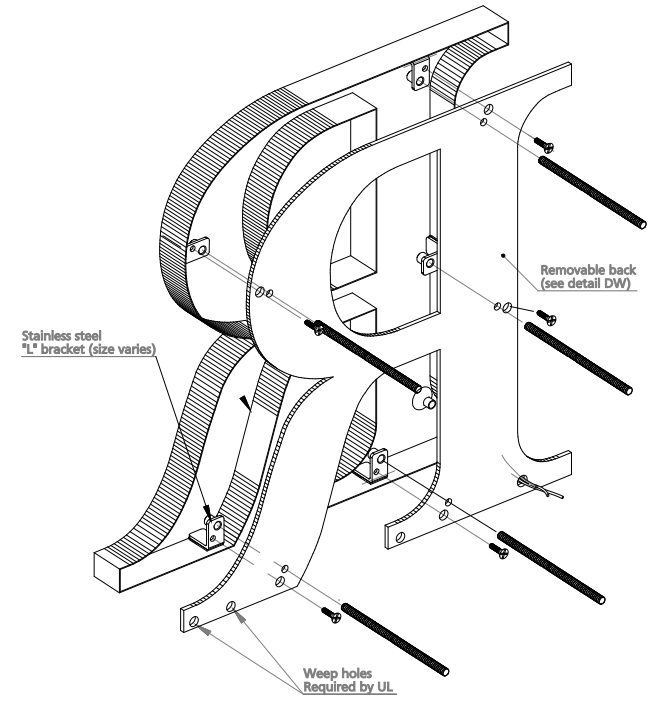

Stainless steel "L" bracket (size varies)

Removable back (see detail DW)

Weep holes Required by UL

"L" bracket secured with high resistance epoxy to return

Flush back secured with stainless steel screw

Threaded Stud Boss Size varies by bracket

Removable clear or light diffused Lexan or stainless steel back.

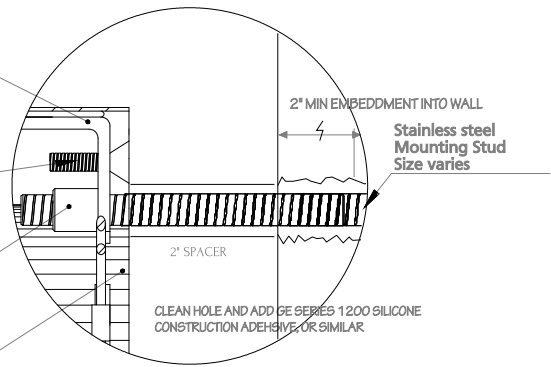

2" MIN EMBEDDMENT INTO WALL

Stainless steel Mounting Stud Size varies

2" SPACER

CLEAN HOLE AND ADD GE SERIES 1200 SILICONE CONSTRUCTION ADHESIVE OR SIMILAR

DETAIL DW II SCALE 1:1

COVALDA APARTMENTS
BLADE SIGN OVERVIEW

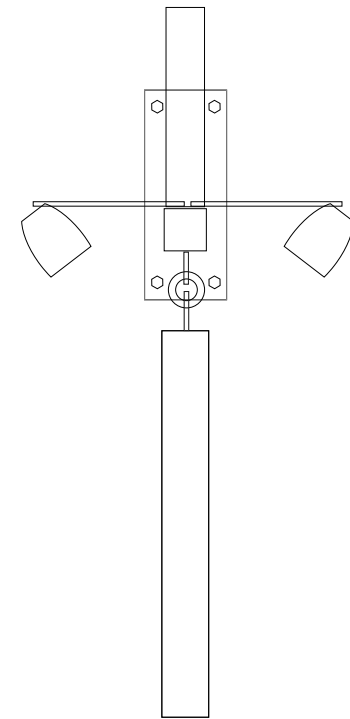
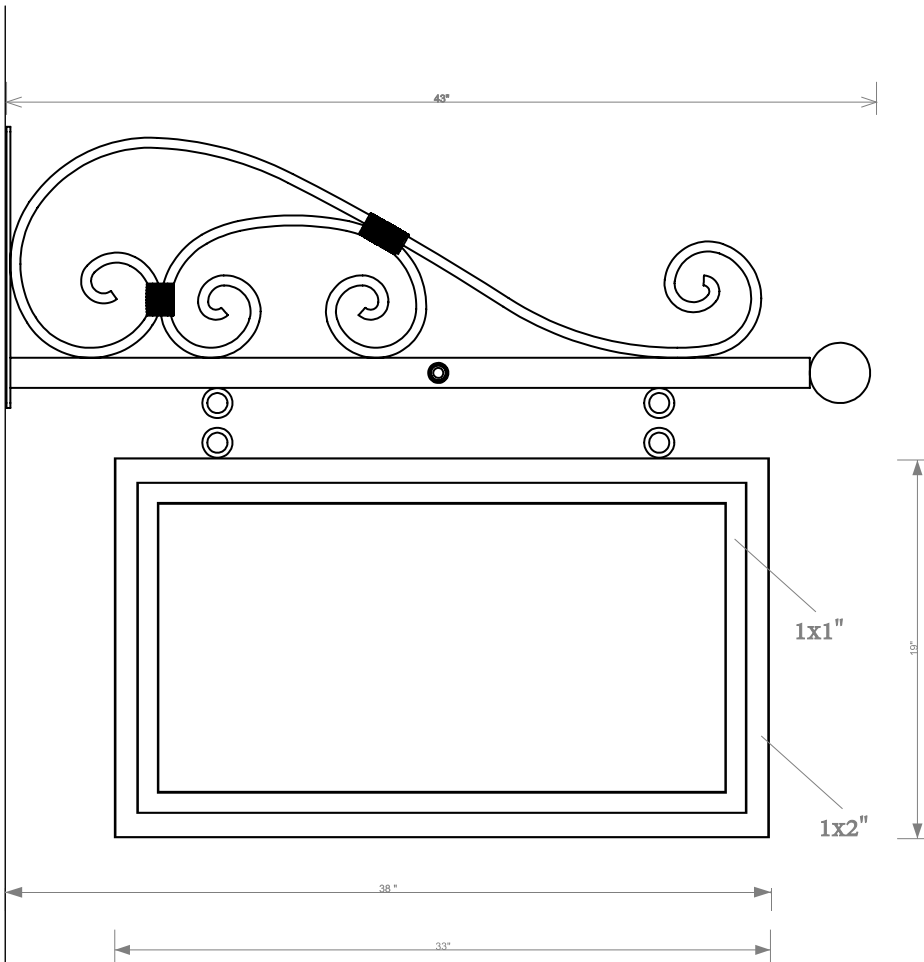

MINIMUM 8" CLEARANCE
FROM FINISHED FLOOR

POWDER COATED STEEL SIGN FRAME
1X2" RECTANGULAR TUBE OUTER FRAME
1X1 SQUARE TUBE INNER FRAME
EYELETS ON TOP WITH 22" O/C SPACING TO MATCH BRACKET
17X31" SIGNS TO ATTACH TO FACE OF 1X1 INNER FRAME WITH 3M VHB TAPE

COVALDA APARTMENTS
 BLADE SIGN BRACKET DETAIL

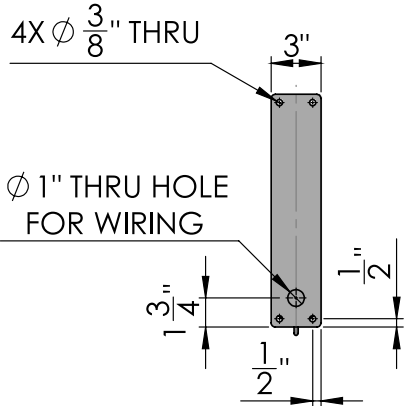
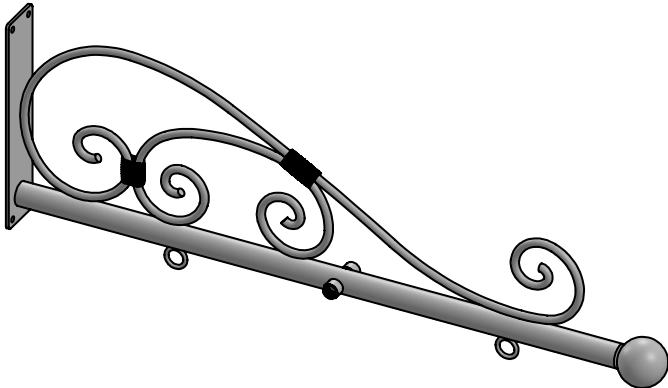

SIDE VIEW

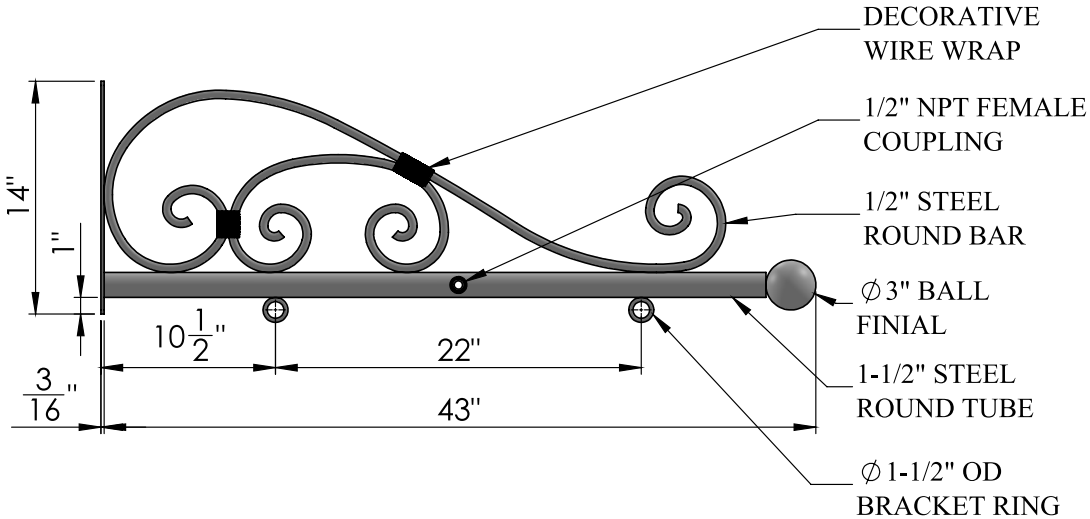

FRONT VIEW

Content: 43" Classic Lighted Sign Bracket
 Color/Finish: Textured Black Powder Coat

Design by Sign Bracket Store. All visual representations and designs are the intellectual property of Sign Bracket Store and protected under copyright law. Any duplication of this design is in direct violation of the law and will result in legal action.

© Copyright 2008-2015

COVALDA APARTMENTS
BLADE SIGN PANEL DETAIL

1/2" THICK LASER CUT ACRYLIC WITH PAINTED DESIGN

ALUMINUM COMPOSITE SUBSTRATE



FLAT HIGH PERFORMANCE VINYL

1/2" THICK LASER CUT ACRYLIC WITH PAINT FINISH

17"x31" SIGN PANEL

TWO PER BLADE SIGN

SIGN TYPE (E) WINDOW SIGNS

QUANTITY	Not limited provided total sign area square footage allowance is not exceeded. May be used in combination with other tenant identification sign types.
LOCATION	On tenant storefront window. Window signs shall only be used on windows for non-residential uses.
COPY	Tenant names/ logo. Window signs include posters for advertisements and sales, product merchandise posters, open and closed signs. and painted or etched business names and logos.
SIZE	All window signs combined shall not occupy more than one-third (1/3) the area of window frontage.
MATERIALS	Permanent window signs shall be created with permanent or fade resistant materials, paint, gold leaf lettering, vinyl or glass etching.
COLORS	Custom colors with Owner approval. Colors Shall be compatible with the building architecture.
TYPE FACE	Custom tenant logotype/ name with Owner approval.
LIGHTING	Direct or indirect

ANCILLARY SIGNS

Ancillary signs are signs other than primary tenant identification signs, and are not included in maximum tenant signage area. Typical ancillary signage includes:

Tenant Door Signs

Each Tenant will be permitted to place upon the main entrance to its premises not more than 3 sq. ft. aggregate area of lettering indicating hours of business, emergency phone numbers, accepted credit cards, etc. Letter height shall be limited to 1-1/2 inches.

Delivery Entrance Identification Signs

Tenants may identify their rear service door for delivery and emergency purposes. Copy shall be limited to identification of the tenant, service or building operation.

TEMPORARY SIGNAGE

Project Leasing / Construction / Future Facilities

Temporary signs are permitted for various activities during and after completion of the development phase:

- may be ground mounted.
- may be internally or externally illuminated at Owner's discretion and approval.
- size and quantity per city zoning ordinances

Temporary Identification / Coming Soon

Temporary signs may be allowed at individual lease spaces for displaying "for lease", "coming soon" and similar messages subject to Owner and City's approval. Tenant is responsible for City approvals or permits if applicable.

Tenants may be allowed use of a temporary identification banner for a period of time not to exceed 30 consecutive days:

- one sign per street frontage
- (2) signs maximum not to exceed a combined total of 60 sq. ft.
- placed below roof eave line

REQUIRED SUBMITTALS AND APPROVALS

A. Submittals and Approvals

There is a formal process for the creation, review and approval of all signage at the project. Prior to submittal to the City, plans for all proposed signage shall be submitted to the Owner or his Authorized Agent who will review plans for conformance with the sign program. **The Owner shall have the discretionary authority to deny approval for any submittal.**

- I. For signage approval, such submissions shall include (4) sets of the following:
 - a. Name, address and phone number of tenant / user
 - b. Name, address and phone number of Sign Contractor
 - c. Elevation of structure showing all proposed signs indicating sign type, design, location, size and layout of sign drawn to scale and indicating dimensions, attachment devices and construction details, colors, materials and lighting details.
 - d. Section detail of letters and/or sign element showing the dimensioned projection of the face of letters, method and intensity of illumination.
 - e. Color board with actual sample colors (8-1/2" x 11" format).
- II. Requests to establish signs that vary from the provisions of this sign program shall be submitted to the Owner in writing for approval prior to being submitted to the City. All proposed variances in an application to the Owner must be clearly identified as such.
- III. Following approval of proposed signage by the Owner, applications for all permits for fabrication and installation by Sign Contractor may be submitted to the City for approval, along with applicable sign permit applications.
- IV. Fabrication and installation of all signs shall be performed in accordance with the standards and specifications outlined in these guidelines and in the final approved plans and working drawings. No sign shall be fabricated prior to approval.

B. Required Insurance and Permits

Prior to installation, the tenant shall provide to the Owner an original certificate of insurance from his sign contractor naming the Owner as an additional insured for liability coverage and a copy of the sign permits issued by the City.