



PRELIMINARY TECHNICAL INFORMATION REPORT

NE 13th Street Site Plan City of Camas, Washington

Prepared by:

**PLS Engineering
Consulting Engineers and Planners
604 W Evergreen Blvd
Vancouver, WA 98660
(360) 944-6519
pm@plsengineering.com**

Prepared for:

**Taz Khan
3993 NW Currawong Court
Camas, WA 98607**

Prepared: November of 2023

TABLE OF CONTENTS

CERTIFICATE OF ENGINEER.....	1
SECTION A – PROJECT OVERVIEW	2
SECTION B – MINIMUM REQUIREMENTS.....	3
SECTION C – SOILS EVALUATION.....	5
SECTION D – SOURCE CONTROL.....	5
SECTION E – ON-SITE STORMWATER MANAGEMENT BMPS	6
SECTION F – RUNOFF TREATMENT ANALYSIS AND DESIGN.....	7
SECTION G - FLOW CONTROL ANALYSIS AND DESIGN.....	8
SECTION H – WETLAND PROTECTION.....	8
SECTION I – OTHER PERMITS	8
SECTION J – CONVEYANCE SYSTEMS ANALYSIS AND DESIGN	8
SECTION K – SPECIAL REPORTS AND STUDIES	8
SECTION L –OPERATIONS AND MAINTENANCE MANUAL	8

Technical Appendices:

Appendix A: Maps

- Vicinity Map
- Soils Map
- Critical Areas Map
- Basin Maps

Appendix B: Design Calculations & Modeling

Appendix C: Geotechnical Report

Appendix D: Operations and Maintenance Manual

Appendix E: Construction Stormwater Pollution Prevention Plan (SWPPP)

Appendix F: Environmental Documentation

CERTIFICATE OF ENGINEER

***NE 13th Street Gas Station Site Plan
Technical Information Report***

The technical information and data contained in this report was prepared under the direction and supervision of the undersigned, whose seal, as a professional engineer licensed to practice as such, is affixed below.



This document was prepared by:

Scott W. Gilliland, PE

Section A – Project Overview

Section A.1 – Site Information

This project will comply with current City of Camas Standards for Stormwater and Erosion Control per CMC Title 14. The Final Grading / Erosion Control / Drainage Plans have been prepared by the project civil engineer, PLS Engineering, Inc. The site will be served by public sewer and water provided by the City of Camas. This project proposes construction of a gas station along with associated structures, access, paved areas, sewer, water, and storm drain connections. Access to the site is from NE 13th Street.

The physical address of the site is currently 20101 NE 13th Street, but the postal office may change that prior to the completion of this project. The parcel serial number is 176148000. The property is located in the Northwest quarter of Section 29, T2N, R3E of the Willamette Meridian. The property is bordered by NE 13th Street on the north side, 1 acre single family lots to the West, NW Friberg-Strunk Street to the East, and Business Park to the South. The cumulative property area contains a total of 42,257 square feet (0.97 acres), with 1,832 square feet (.04 acres) of right of way dedication, resulting in 40,425 square feet (0.93 acres) of developed area. This technical information report will address the stormwater runoff associated with the construction which will take place.

The topography of the site is set below the bordering roadways by approximately 2' and slightly sloped from the high point at the NW corner of the site towards the SW and SE corners of the site. Elevations range from approximately 249' to 244'. Slopes are generally between 1% and 7%, while the slopes at the edge of the Northern and Eastern boundary roads are around 33%. The site contains a 1,600 square-foot house and a 150 square-foot shop. These structures are planned to be removed. The remainder of the site is filled with grass, landscaping, and a variety of trees. There are potential wetlands mapped on Clark County Maps South of the site. There is a White Oak located on the South edge of the site. Otherwise, there are no known water courses, areas prone to flooding, floodplains, shoreline areas, water bodies, unstable slopes, landslide hazard areas, habitat, critical areas, or historic sites located on the site. Site drainage follows the slope of the land going from the NW corner to the SE/SW corners. There are also some isolated low points on site. The site runoff currently flows to the South, but that is clearly not the historical flow from the site. It appears that when NE 13th Street, and NW Friberg-Strunk Street were created, they were raised above the property and effectively dammed off the site. Historically, the flow from this site traveled to the NE towards Lacamas Creek.

Site runoff from PGIS surfaces will be routed to a cartridge vault for treatment. The treated runoff and any other runoff not routed to the vault will flow to an underground detention system. The detention system was modeled using WWHM software to discharge flows in compliance with the SWMMWW. The detention system discharges to an existing MH in NE 13th Street where it will be routed to a roadside ditch located on the North side of NE Goodwin road where it will eventually reach Lacamas creek, returning the site flows to their historical flow path.

Existing frontage on NE 13th Street is currently flowing in two different directions. The North side of the street is routed to the East where it eventually flows into Lacamas Creek. The South side of the street is routed to the South where it is treated and discharged as part of a City road project. The discharge appears to flow to a Wetland located East of NW Friberg-Strunk Street. The site discharge

historically followed the flow path of the North side of the road and is being discharged to that storm system. Consequently, this project has two TDA's. Runoff from the South side of 13th is identified as TDA 1, and will only include the existing and proposed frontage improvements along 13th. TDA 2 will include the roadway improvements on the North side of 13th, as well as the site improvements.

Section B – Minimum Requirements

Section B.2 – Determination of Applicable Minimum Requirements

After site development, disturbed impervious surfaces will cover approximately 49,280 square feet, resulting in more than 5,000 square foot of hard surface area. Consequently, this site must meet all nine Minimum Requirements of the stormwater manual. The site area and the North side of 13th will discharge to TDA 2, and the frontage improvements on the South side of 13th will discharge to TDA 1. The minimum requirements for the TDA's will be different. The areas for each TDA are summarized below. The stormwater system is designed to comply with all City requirements for stormwater treatment and quantity control. The treatment regulations require treatment of 91% of the total runoff volume from pollution generating impervious surfaces while the quantity control regulations require that post-development discharges shall match pre-developed durations for the range of pre-developed discharge rates from 50% of the 2-year peak flow up to the full 50-year peak flow.

Total Site Area:

Existing hard surface	12,106 ft ²
New hard surface	35,442 ft ²
Replaced hard	7,566 ft ²
Native vegetation converted to lawn or landscaping	9,829 ft ²
Native vegetation converted to pasture	0 ft ²
Total land-disturbing activity	1.21 acre
Pollution-generating hard surface	30,977 ft ²
Pollution-generating pervious surface	0 ft ²
New Pollution-generating hard surface	23,634 f t ²
Total pollution-generating surfaces	31,200 ft ²
Total non-pollution-generating surfaces	20,078 ft ²

TDA 1:

Existing hard surface	7,566 ft ²
New hard surface	3,091 ft ²
Replaced hard	7,566 ft ²
Native vegetation converted to lawn or landscaping	895 ft ²
Native vegetation converted to pasture	0 ft ²
Total land-disturbing activity	0.26 acre
Pollution-generating hard surface	8,875 ft ²
Pollution-generating pervious surface	0 ft ²
New Pollution-generating hard surface	1,532 f t ²
Total pollution-generating surfaces	9,098 ft ²
Total non-pollution-generating surfaces	895 ft ²

TDA 2:

Existing hard surface	4,540 ft ²
New hard surface	32,351 ft ²
Replaced hard	0 ft ²
Native vegetation converted to lawn or landscaping	8,934 ft ²
Native vegetation converted to pasture	0 ft ²
Total land-disturbing activity	0.95 acre
Pollution-generating hard surface	22,102 ft ²
Pollution-generating pervious surface	0 ft ²
New Pollution-generating hard surface	22,102 ft ²
Total pollution-generating surfaces	22,102 ft ²
Total non-pollution-generating surfaces	19,183 ft ²

MR #1) Preparation of Stormwater Site Plans

All Stormwater System designs meet City of Camas Requirements for conveyance, quality control and quantity. See final construction documents for more details.

MR #2) Construction Stormwater Pollution Prevention

A Stormwater Pollution Prevention Plan is being included with this report and will be onsite for the duration of the project's construction.

MR #3) Source Control of Pollution

See Section D

MR #4) Preservation of Natural Drainage Systems and Outfalls

The historic flow path from the site was to the NE. The South side of 13th was artificially routed to away from the historic flow path and to the South. This flow path will remain unchanged. The North side of 13th is currently following the historic flow path to the NE and will remain unchanged. The site runoff was dammed off by the roadways located North and East of the site, and its historic flow path was changed to the South. This project will restore the site to its historic flow path. This will maintain and preserve the natural drainage systems.

MR #5) Onsite Stormwater Management

See Section E

MR #6) Runoff Treatment

See Section F

MR #7) Flow Control

See Section G

MR #8) Wetland Protection

Clark County maps show the potential for a Wetland located South of the site. See Appendix F for documentation showing that there are not any wetlands on the site.

MR #9) Operations and Maintenance
See Appendix D

Section C – Soils Evaluation

The soils are mapped by the NRCS as Wind River gravelly loam (WrB) for the majority of the site, and Cove silty clay loam (CwA) at the SW corner and Eastern edge of the site.

Earth Engineering Inc. investigated the site on August 4, 2023, and provided a Geotechnical report for the site on August 31, 2023. The geotechnical investigation identified the subsurface soils on site as hard silty clay soils. Consequently, the site was modeled assuming soil type SG4. The geotechnical report has been included in Appendix C and a soil map is included in Appendix A.

Section D – Source Control

The pollution risks involved with this project mainly include the sediment accumulation involved with construction. The Stormwater Pollution Prevention Plan is a document that notes our certain Best Management Practice's (BMP's) that will help prevent sediment laden water from leaving the site during construction. The Erosion Control Plan located in the final construction drawings will provide protection measures involved with minimizing the chance that sediment from the site could enter downstream waterways. The SWPPP is provided in Appendix E.

After construction is complete, this site will be a Gas Station, with special source control measures required. The following Source Control BMPs should be implemented after construction to meet the MR# 3 requirements:

- **BMP S409: BMP's for Fueling at Dedicated Stations.**
- **BMP S412: BMP's for Loading and Unloading Areas of Liquid or Solid Materials.**
- **BMP S426: BMP's for Spills of Oil and Hazardous Substances.**
- **BMP S455: BMP's for Spill Prevention and Cleanup.**

Section E – On-site Stormwater Management BMPs

Minimum Requirement 5 requires the applicant to employ On-site Stormwater Management BMPs in accordance with the following project thresholds, standards, and lists to infiltrate, disperse, and retain stormwater runoff on-site to the maximum extent feasible without causing flooding or erosion impacts. Based on section I-2.5.1 of the Western Washington Stormwater Manual the development is within the UGA on a parcel that is less than 5 acres therefore Low Impact Development Performance Standards and BMP T5.13; or List #2 will apply (applicant option). Due to negligible infiltration rates, this project will apply List #2. If certain BMP's are infeasible; infeasibility criteria per the 2019 Stormwater Management Manual for Western Washington are also noted.

List #2:

Lawn and Landscape areas:

BMP T5.13 Post-Construction Soil Quality and Depth:

This requirement will be met during final design and shown on final construction drawings.

Roofs:

BMPT5.30A or T5.30B Full Dispersion:

There is insufficient area and length to provide a 100' flow path to meet the requirements of full dispersion while still maintaining sufficient spacing to prevent overlap.

BMPT5.14A or BMPT5.14B Rain Gardens and Bioretention:

The soil permeability factor above groundwater is less than 0.3 inches per. Because the site soils don't accommodate infiltration, this is not a feasible infiltration BMP as part of Minimum requirement #5.

BMPT5.10C Downspout Dispersion Systems:

There is insufficient space to meet the required dispersion lengths and setbacks from the structures and the property lines.

BMP T5.10D Perforated Stub-out Connections

There is insufficient space to meet the required setback of 10' away from the structures and property lines, and infiltration rates are less than 0.3 inches per hour.

Other Hard Surfaces:

BMPT5.30A or T5.30B Full Dispersion:

There is insufficient area and length to provide a 100' flow path to meet the requirements of full dispersion while still maintaining sufficient spacing to prevent overlap.

BMPT5.15 Permeable Pavement:

Permeable pavement is insufficient due to soil infiltration above the groundwater table being less than 0.3 in/hr.

BMPT5.14A or BMPT5.14B Rain Gardens and Bioretention:

The soil permeability factor above groundwater is less than 0.3 inches per hour. Because the site soils don't accommodate infiltration, this is not a feasible infiltration BMP as part of Minimum requirement #5.

BMPT5.12 Sheet Flow Dispersion:

There is insufficient area and length to provide a 100' flow path to meet the requirements of full dispersion while still maintaining sufficient spacing to prevent overlap.

None of the List 2 requirements can be met by this project. Consequently, site stormwater runoff from this project will be treated and detained prior to discharge as described in Sections F and G of this report.

The following BMPs will be implemented to meet the MR# 5 requirements:

- **BMP T5.13: Post-Construction Soil Quality and Depth** for lawn and landscaped areas.
- **BMP D.2: Detention Tanks** for runoff from the site.
- **BMP V10.0: Manufactured Treatment Devices** for runoff from the site.
- **BMP T11.11: Coalescing Plate (CP) Separator** for treatment of fuel station spills, mini-mart grease, and car wash oils.

Section F – Runoff Treatment Analysis and Design

Treatment for the site will be accomplished with Contech treatment cartridges. Preliminary stormwater analysis with a WWHM model (see appendix B) identifies the water quality storm event for the site as 0.1213. This volume includes roof, landscape, and frontage runoff, which will not all be treated as part of the final design. The Contech sizing table below identifies treatment flow rates for different cartridges. For example, the 18" ZPG cartridges will each treat 0.028 cfs. Based on this preliminary analysis, there will be 5 or less 18" cartridges needed to treat the stormwater runoff from the site. Due to elevation issues it might be necessary to use low drop cartridges which would result in 7 or less ZPG cartridges. This site is very tight vertically, so the preliminary rim elevations and pipe IE's were sent to Contech who verified that their treatment cartridges will operate properly under the proposed backwater conditions.

Table 1-Contech Sizing Chart

StormFilter	2 GPM/ft ²			1 GPM/ft ²			1.67 GPM/ft ²		
	Flow (GPM)	Flow (CFS)	Color	Flow (GPM)	Flow (CFS)	Color	Flow (GPM)	Flow (CFS)	Color
LowDrop	10	0.022	Gray (GRY)	5.00	0.011	Blue (BLU)	8.35	0.019	Yellow (YLW)
18"	15	0.033	Black (BLK)	7.50	0.017	Blue (BLU)	12.53	0.028	Red (RED)
27"	22.5	0.05	Gold (GLD)	11.50	0.025	Pink (PNK)	18.79	0.042	White (WHT)

Section G - Flow Control Analysis and Design

The stormwater quantity control system for this site has been designed based on the current stormwater quantity control requirements of the City of Camas. The quantity control standards require that stormwater discharges shall match developed discharge durations to pre-developed durations for the range of pre-developed discharge rates from 50% of the 2-year peak flow up to the full 50-year peak flow.

The runoff from this site will be detained in an underground detention facility. The preliminary design assumes 6 x 136' 24" CMP pipes placed in gravel. The gravel has a porosity of 0.40. Underground storage was modelled in WWHM using a trench. In order to properly model the 24" CMP in the underground storage, the porosity for the rock was calculated and averaged out to be 0.7326. The WWHM model shows that it passed and meets the discharge requirements of the SWMMWW.

See Appendix B for calculations.

Section H – Wetland Protection

There are not any wetlands on the site. See appendix F.

Section I – Other Permits

The project will be required to obtain preliminary site plan approval, final site plan approval, construction drawing approval, an NPDES construction stormwater permit, and building permit approval prior to construction.

Section J – Conveyance Systems Analysis and Design

Conveyance will be provided with the Final TIR.

Section K – Special Reports and Studies

A Geotechnical Report for the site is included in Appendix C. A Critical Areas report and a Mitigation plan are included in Appendix F. No other special studies are anticipated to be needed.

Section L –Operations and Maintenance Manual

The stormwater facility located on-site will be maintained by the site owner. An Operations and Maintenance Manual is included as Appendix D of this report.

SEPARATOR SHEET

APPENDIX A

Maps



Soils Map

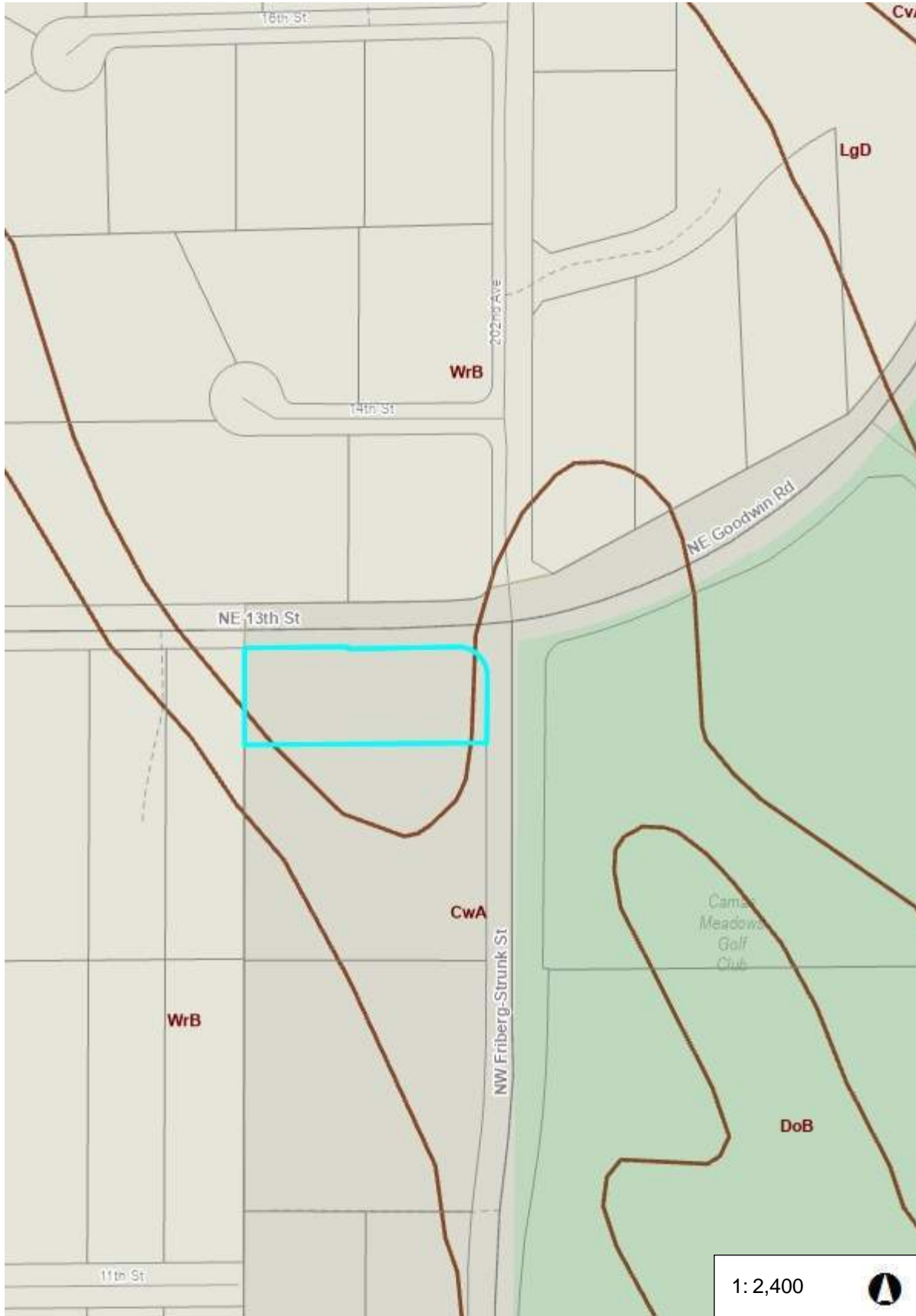

Legend

- Taxlots
- Soil Type

Notes:

1:2,400

400.0 0 200.00 400.0Feet



Critical Areas Map

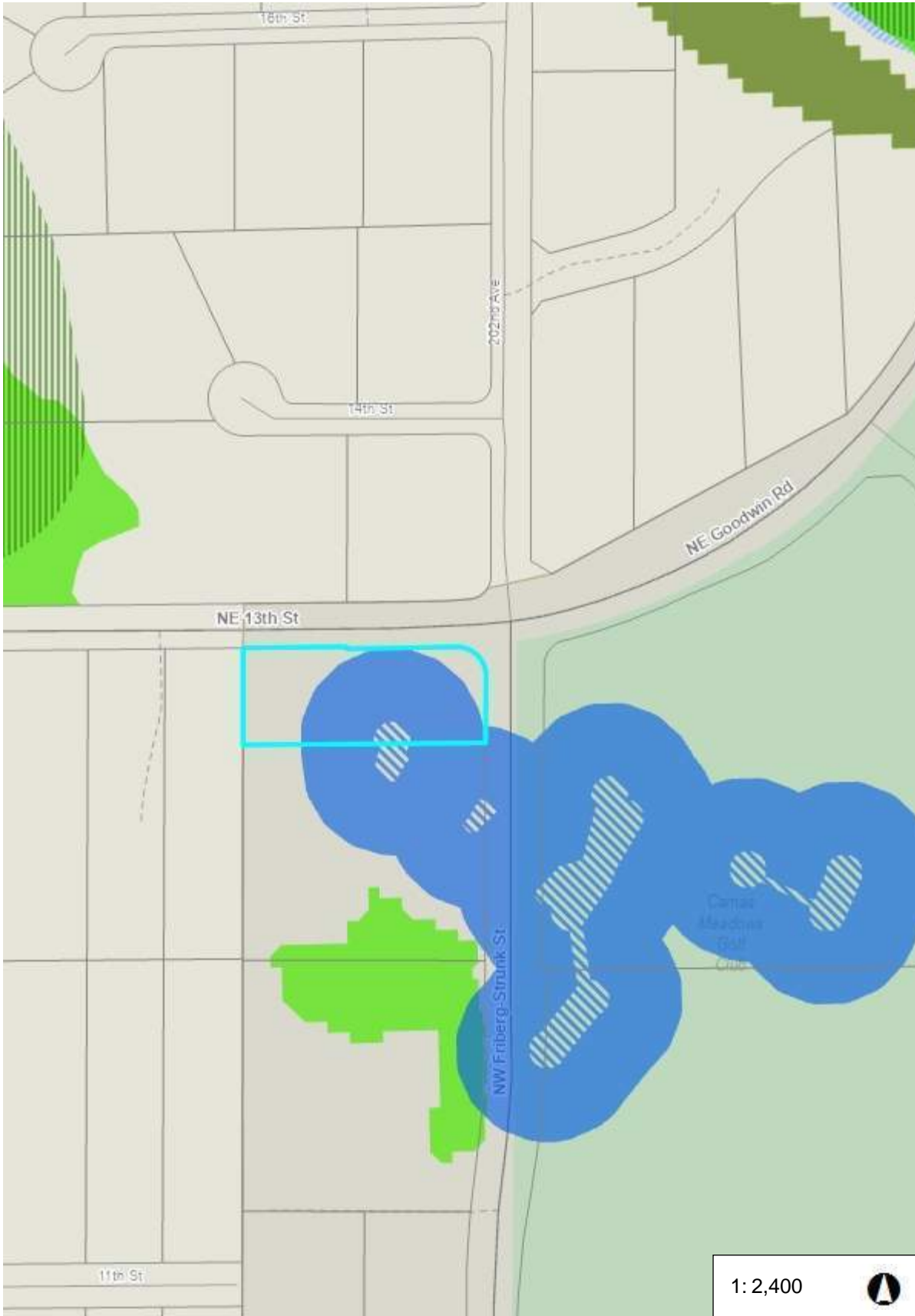

Legend

- Taxlots
- Species**
 - Species Area
 - Adjacent to Species Area
- Habitat**
 - Habitat Area
 - Adjacent to Habitat Area
- Riparian Habitat
- Severe Erosion Hazard Areas
- Steep Slopes and Landslide H:**
 - Areas of Historic or Active Landslides
 - Areas of Potential Instability
 - Areas of Older Landslide Debris
 - Slopes > 15%
 - Slopes > 25%
- Potential Wetlands Presence
- Flood Zone Designation**
 - Floodway
 - Floodway Fringe
 - 500 Year Flood Area
 - Area Not Studied
- Shoreline Designations**
 - Aquatic
 - Natural
 - Urban Conservancy
 - Medium Intensity
 - High Intensity
 - Rural Conservancy Residential
 - Rural Conservancy Resource Land
- Critical Aquifer Recharge Area

Notes:

1: 2,400

400.0 0 200.00 400.0 Feet

13th Street Site Plan

Located in the NW ¼ of Section 29, T2N, R3E, W.M.
City of Camas, Washington

Sheet Index	
1.	Predevelopment Basin Map
2.	Postdevelopment Basin Map

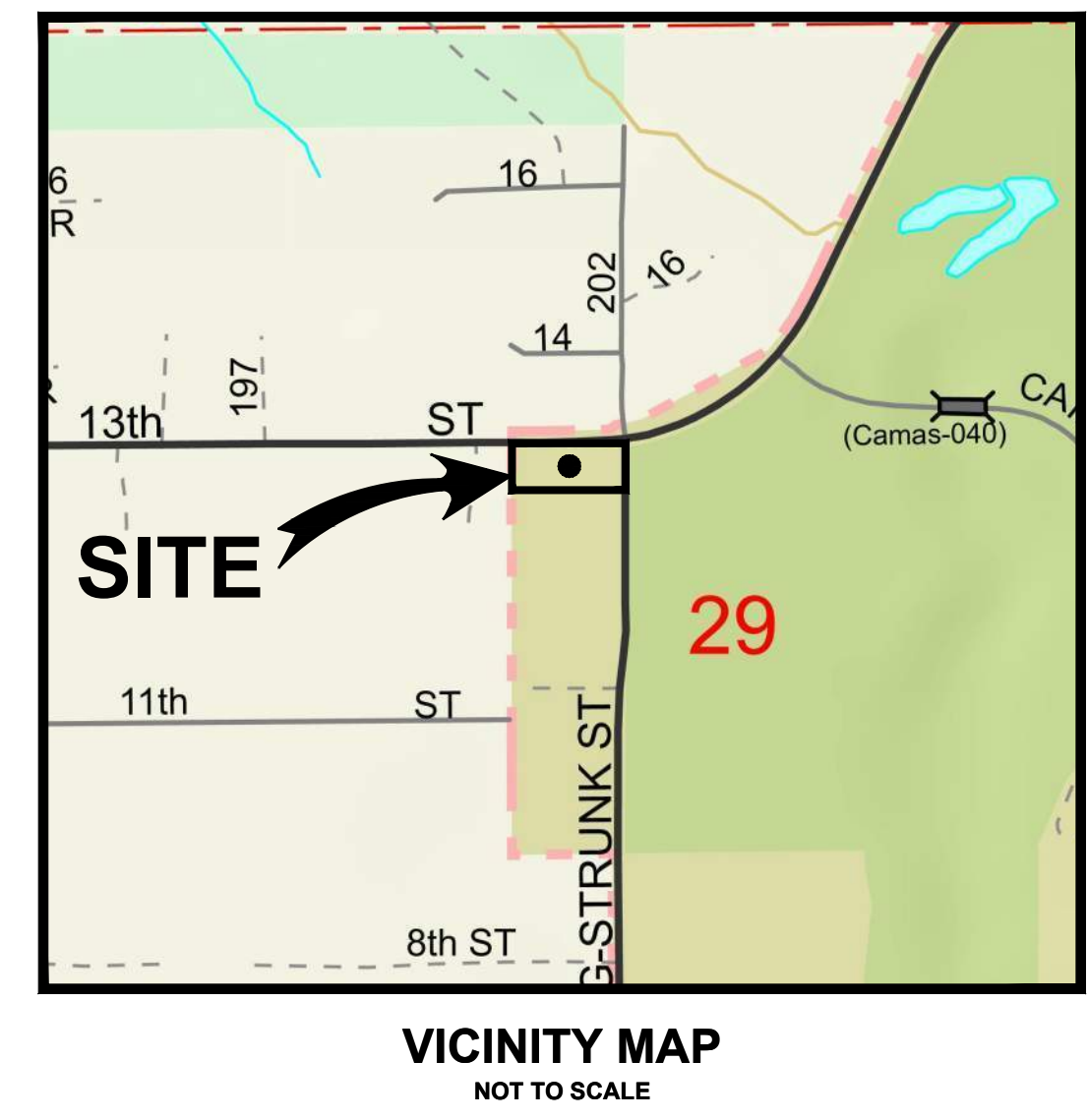

Extg TDA Totals		
	sqft	acre
TDA 1 Area	11,551.38	0.2652
Frontage Road	7,565.86	0.1737
Frontage Landscape	3,985.52	0.0915
TDA 2 Area	41,285.00	0.9478
Site Driveway	2,449.31	0.0562
Site Sidewalk	154.38	0.0035
Site Roof	1,936.36	0.0445
Site Landscape	36,744.94	0.8435
Existing Site Area Modeled as Forested	41,285.00	0.9478

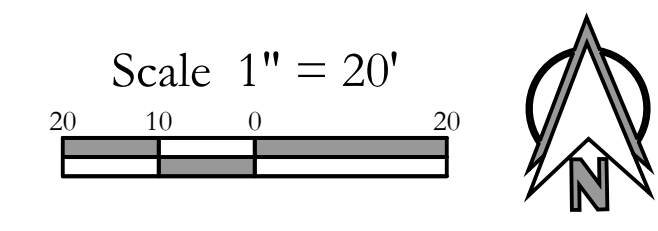

Drainage Basin Legend	
POC Line	— — — — —
Basin Line	- - - - -
Subcatchment Area ID	#

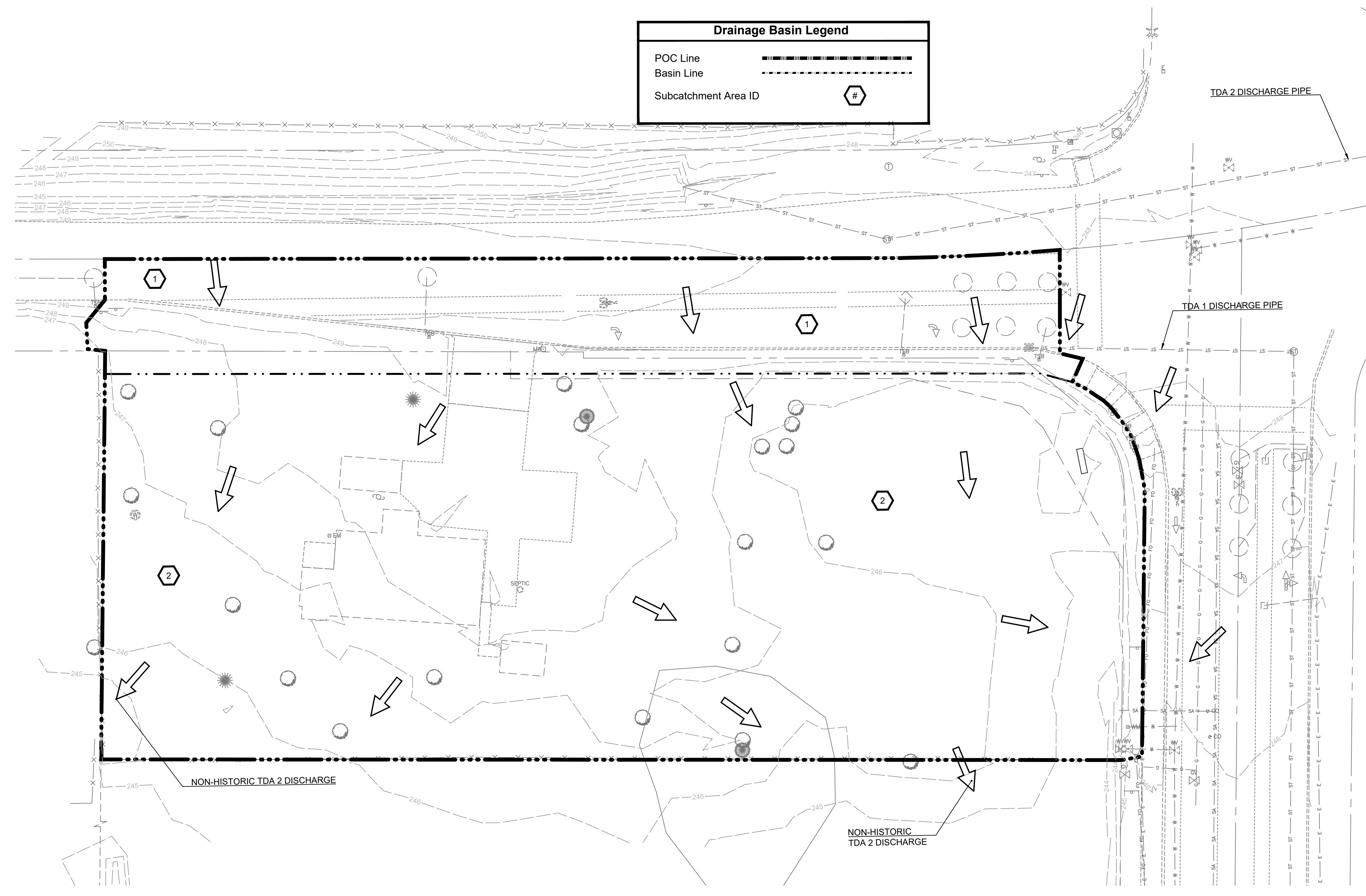

GENERAL NOTES

APPLICANT:
Taz Kahn
3993 NW Currawong Court
Camas, WA 98607
TKahnusa@gmail.com

OWNER:
Pak USA Camas LLC
20107 NE 13th Street
Camas, WA 98607

CIVIL ENGINEER:
PLS Engineering
Contact: Travis Johnson, PE
604 W Evergreen Blvd
Vancouver, WA 98660
PH: (360) 944-6519
pm@plsengineering.com

SITE ADDRESS:
Parcel # 176148-000
20101 NE 13TH ST
Camas, WA 98607

SITE STATISTICS:
Existing Site Area: 42,257 SF (0.97 Acre)
ROW Dedication: 1,832 SF (0.04 Acre)
Developed Site: 42,257 SF (0.93 Acre)

Predevelopment Basin Map For:
13th Street Site Plan
A Subdivision Located In The City Of Camas, Washington

Revisions	
No.	Description
1	
2	
3	
4	
5	
6	

Project No. 3632
SCALE: H: 1" = 50' V: N/A
DESIGNED BY: SWG
DRAFTED BY: JSV
REVIEWED BY: TGJ

13th Street Site Plan

Located in the NW ¼ of Section 29, T2N, R3E, W.M.
City of Camas, Washington

Sheet Index	
1.	Predevelopment Basin Map
2.	Postdevelopment Basin Map

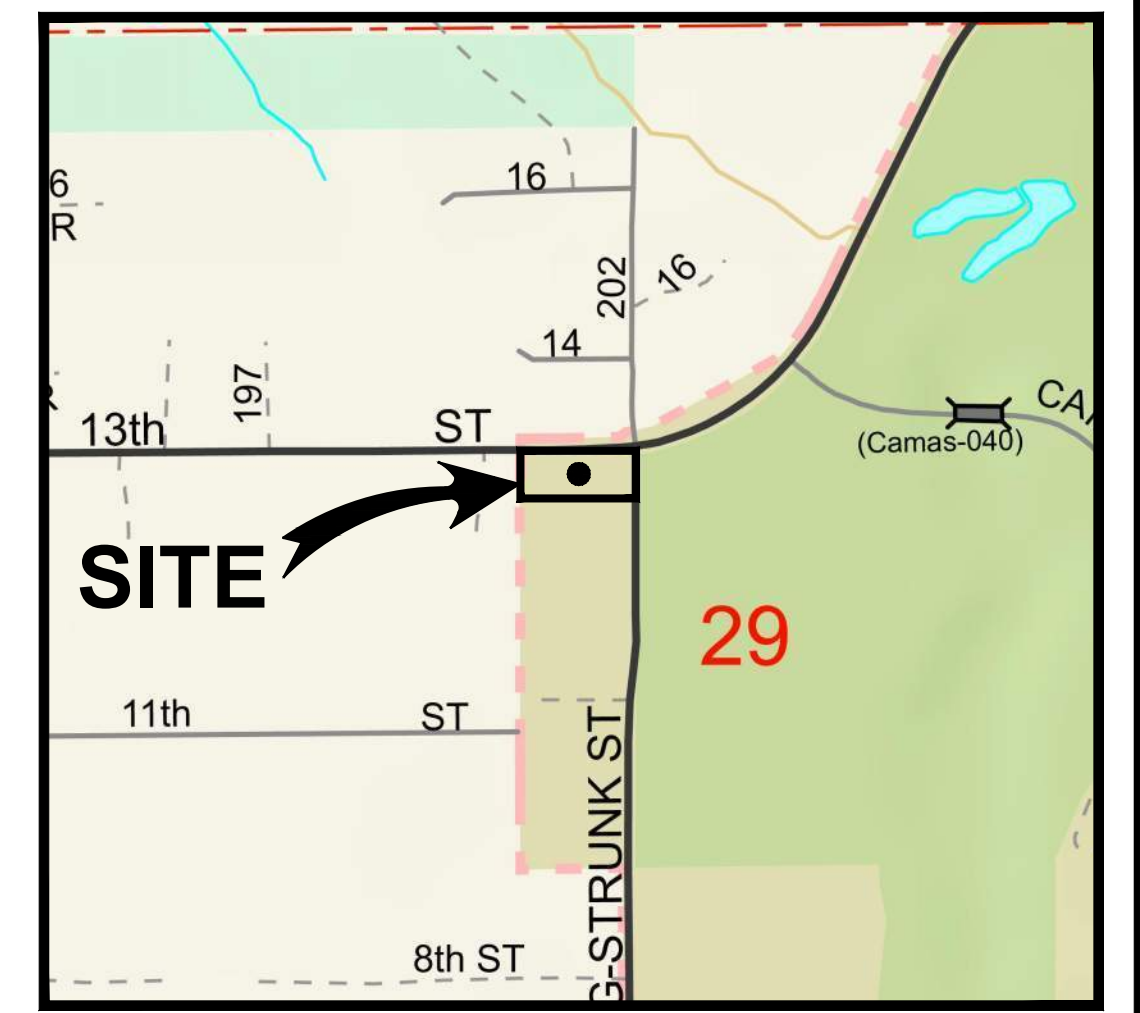

VICINITY MAP
NOT TO SCALE

Basin Areas (sqft)							
	Basin	Road	SW	Roof	Field	Landscape	Total
1	TDA 1 Basin 1 Frontage	9,097.51	1,559.09	-	-	894.78	11,551.38
2	TDA 2 Basin 3 Site	22,101.84	2,490.08	7,759.05	-	8,934.03	41,285.00
Total		31,199.36	4,049.16	7,759.05	-	9,828.81	52,836.38

Basin Areas (acre)							
	Basin	Road	SW	Roof	Field	Landscape	Total
1	TDA 1 Basin 1 Frontage	0.2089	0.0358	-	-	0.0205	0.2652
2	TDA 2 Basin 3 Site	0.5074	0.0572	0.1781	-	0.2051	0.9478
Total		0.7162	0.0930	0.1781	-	0.2256	1.2130

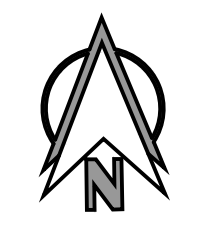
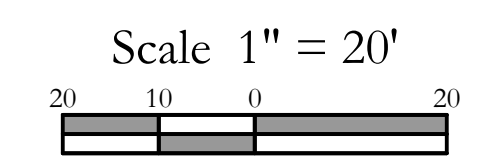

Drainage Basin Legend	
POC Line	— — — — —
Basin Line	- - - - -
Subcatchment Area ID	#

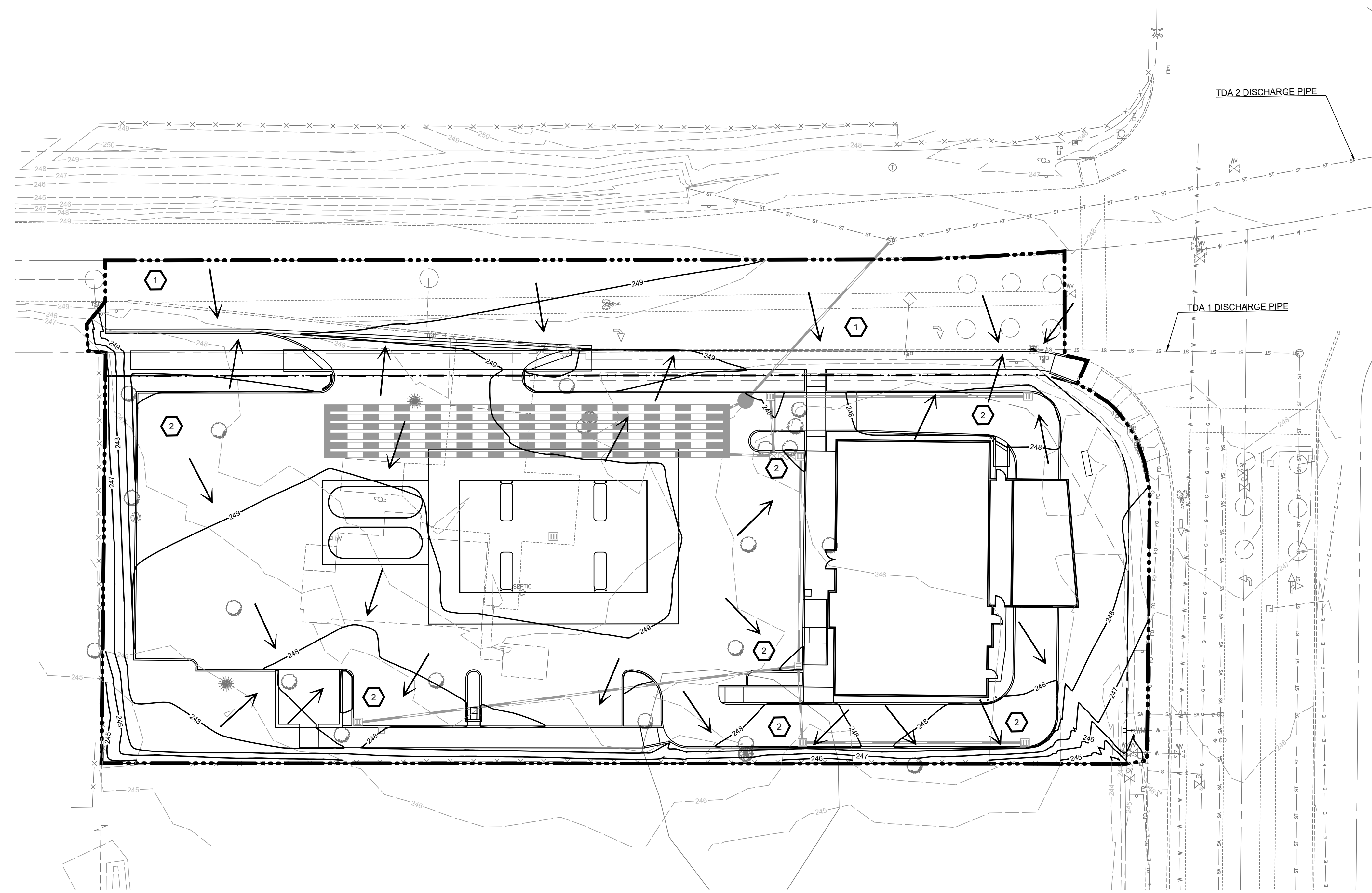

GENERAL NOTES

APPLICANT:
Taz Kahn
3993 NW Currawong Court
Camas, WA 98607
TKahnusa@gmail.com

OWNER:
Pak USA Camas LLC
20107 NE 13th Street
Camas, WA 98607

CIVIL ENGINEER:
PLS Engineering
Contact: Travis Johnson, PE
604 W Evergreen Blvd
Vancouver, WA 98660
PH: (360) 944-6519
pm@plsengineering.com

SITE ADDRESS:
Parcel # 176148-000
20101 NE 13TH ST
Camas, WA 98607

SITE STATISTICS:
Existing Site Area: 42,257 SF (0.97 Acre)
ROW Dedication: 1,832 SF (0.04 Acre)
Developed Site: 42,257 SF (0.93 Acre)

Post-Development Basin Map For:
13th Street Site Plan
A Subdivision Located In The City Of Camas, Washington

Revisions	
1	
2	
3	
4	
5	
6	

Project No.	3632
SCALE:	H: 1" = 50' V: N/A
DESIGNED BY:	SWG
DRAFTED BY:	JSV
REVIEWED BY:	TGJ

SEPARATOR SHEET

APPENDIX B

Design Calculations and Modeling

Proposed TDA Totals		
	sqft	acre
Total Development	52,836.38	1.2130
Road	31,199.36	0.7162
Sidewalk	4,049.16	0.0930
Roof	7,759.05	0.1781
Landscape	9,828.81	0.2256
Impervious Area	43,007.57	0.9873
Pervious Area	9,828.81	0.2256
Pollution Generating Impervious Surface Area (PGIS)	31,199.36	0.7162
TDA 1	11,551.38	0.2652
Road	9,097.51	0.2089
Sidewalk	1,559.09	0.0358
Landscape	894.78	0.0205
TDA 1 New Impervious	3,090.74	0.0710
TDA 1 Replaced Impervious	7,565.86	0.1737
TDA 1 New PGIS	1,531.66	0.0352
TDA 1 Replaced PGIS	7,565.86	0.1737
TDA 2	41,285.00	0.9478
Road	22,101.84	0.5074
Sidewalk	2,490.08	0.0572
Roof	7,759.05	0.1781
Landscape	8,934.03	0.2051
TDA 2 New Impervious	32,350.97	0.7427
TDA 2 Replaced Impervious	-	-
TDA 2 New PGIS	22,101.84	0.5074
TDA 2 Replaced PGIS	-	-

Extg TDA Totals		
	sqft	acre
TDA 1 Area	11,551.38	0.2652
Frontage Road	7,565.86	0.1737
Frontage Landscape	3,985.52	0.0915
TDA 2 Area	41,285.00	0.9478
Site Driveway	2,449.31	0.0562
Site Sidewalk	154.38	0.0035
Site Roof	1,936.36	0.0445
Site Landscape	36,744.94	0.8435
Existing Site Area Modeled as Forested	41,285.00	0.9478

Basin Areas (sqft)						
Basin	Road	SW	Roof	Field	Landscape	Total
TDA 1 Basin 1 Frontage	9,097.51	1,559.09	-	-	894.78	11,551.38
TDA 2 Basin 3 Site	22,101.84	2,490.08	7,759.05	-	8,934.03	41,285.00
Total	31,199.36	4,049.16	7,759.05	-	9,828.81	52,836.38

Basin Areas (acre)						
Basin	Road	SW	Roof	Field	Landscape	Total
TDA 1 Basin 1 Frontage	0.2089	0.0358	-	-	0.0205	0.2652
TDA 2 Basin 3 Site	0.5074	0.0572	0.1781	-	0.2051	0.9478
Total	0.7162	0.0930	0.1781	-	0.2256	1.2130

WWHM Basin Treatment Flow Analysis (cfs)						
	WQ	2-yr	10-yr	25-yr	50-yr	100-yr
Total Site Treatment	0.1213	0.568841	0.844412	0.987932	1.097315	1.208959

Underground Storage Calculations		
17' Wide x 2' Tall is	34.0000	SF
6x24" CMP is	18.8496	SF
Rock Storage @ 40% Porosity	6.0602	SF
Total Storage	24.9097	SF
Porosity Tweaked to match	73.26%	
Facility Length	130.0000	LF
Total Facility Volume	4,420.0000	CF
Facility Storage	3,238.2654	CF

SEPARATOR SHEET

WWHM2012
PROJECT REPORT

General Model Information

WWHM2012 Project Name: 13thPrelimStormAnalysis

Site Name: 13th Gas Station

Site Address:

City:

Report Date: 11/3/2023

Gage: Lacamas

Data Start: 1948/10/01

Data End: 2008/09/30

Timestep: 15 Minute

Precip Scale: 1.300

Version Date: 2023/01/27

Version: 4.2.19

POC Thresholds

Low Flow Threshold for POC1: 50 Percent of the 2 Year

High Flow Threshold for POC1: 50 Year

Landuse Basin Data

Predeveloped Land Use

TDA 2 EXTG

Bypass:	No
GroundWater:	No
Pervious Land Use	acre
SG4, Forest, Flat	0.9478
Pervious Total	0.9478
Impervious Land Use	acre
Impervious Total	0
Basin Total	0.9478

*Mitigated Land Use***TDA 2 Basin 3 Site**

Bypass:	No
GroundWater:	No
Pervious Land Use	acre
SG4, Lawn, Flat	0.2051
Pervious Total	0.2051
Impervious Land Use	acre
ROADS FLAT	0.5074
ROOF TOPS FLAT	0.1781
SIDEWALKS FLAT	0.0572
Impervious Total	0.7427
Basin Total	0.9478

Routing Elements
Predeveloped Routing

Mitigated Routing

Underground Detention

Bottom Length: 136.00 ft.
 Bottom Width: 17.00 ft.
 Trench bottom slope 1: 0 To 1
 Trench Left side slope 0: 0 To 1
 Trench right side slope 2: 0 To 1
 Material thickness of first layer: 2
 Pour Space of material for first layer: 0.7326
 Material thickness of second layer: 0
 Pour Space of material for second layer: 0
 Material thickness of third layer: 0
 Pour Space of material for third layer: 0
 Discharge Structure
 Riser Height: 2 ft.
 Riser Diameter: 10 in.
 Notch Type: Rectangular
 Notch Width: 0.270 ft.
 Notch Height: 0.400 ft.
 Orifice 1 Diameter: 1.900 in. Elevation:0 ft.
 Element Flows To:
 Outlet 1 Outlet 2

Gravel Trench Bed Hydraulic Table

Stage(feet)	Area(ac.)	Volume(ac-ft.)	Discharge(cfs)	Infilt(cfs)
0.0000	0.053	0.000	0.000	0.000
0.0222	0.053	0.000	0.014	0.000
0.0444	0.053	0.001	0.020	0.000
0.0667	0.053	0.002	0.025	0.000
0.0889	0.053	0.003	0.029	0.000
0.1111	0.053	0.004	0.032	0.000
0.1333	0.053	0.005	0.035	0.000
0.1556	0.053	0.006	0.038	0.000
0.1778	0.053	0.006	0.041	0.000
0.2000	0.053	0.007	0.043	0.000
0.2222	0.053	0.008	0.046	0.000
0.2444	0.053	0.009	0.048	0.000
0.2667	0.053	0.010	0.050	0.000
0.2889	0.053	0.011	0.052	0.000
0.3111	0.053	0.012	0.054	0.000
0.3333	0.053	0.013	0.056	0.000
0.3556	0.053	0.013	0.058	0.000
0.3778	0.053	0.014	0.060	0.000
0.4000	0.053	0.015	0.062	0.000
0.4222	0.053	0.016	0.063	0.000
0.4444	0.053	0.017	0.065	0.000
0.4667	0.053	0.018	0.066	0.000
0.4889	0.053	0.019	0.068	0.000
0.5111	0.053	0.019	0.070	0.000
0.5333	0.053	0.020	0.071	0.000
0.5556	0.053	0.021	0.073	0.000
0.5778	0.053	0.022	0.074	0.000
0.6000	0.053	0.023	0.075	0.000
0.6222	0.053	0.024	0.077	0.000

0.6444	0.053	0.025	0.078	0.000
0.6667	0.053	0.025	0.080	0.000
0.6889	0.053	0.026	0.081	0.000
0.7111	0.053	0.027	0.082	0.000
0.7333	0.053	0.028	0.083	0.000
0.7556	0.053	0.029	0.085	0.000
0.7778	0.053	0.030	0.086	0.000
0.8000	0.053	0.031	0.087	0.000
0.8222	0.053	0.032	0.088	0.000
0.8444	0.053	0.032	0.090	0.000
0.8667	0.053	0.033	0.091	0.000
0.8889	0.053	0.034	0.092	0.000
0.9111	0.053	0.035	0.093	0.000
0.9333	0.053	0.036	0.094	0.000
0.9556	0.053	0.037	0.095	0.000
0.9778	0.053	0.038	0.096	0.000
1.0000	0.053	0.038	0.098	0.000
1.0222	0.053	0.039	0.099	0.000
1.0444	0.053	0.040	0.100	0.000
1.0667	0.053	0.041	0.101	0.000
1.0889	0.053	0.042	0.102	0.000
1.1111	0.053	0.043	0.103	0.000
1.1333	0.053	0.044	0.104	0.000
1.1556	0.053	0.044	0.105	0.000
1.1778	0.053	0.045	0.106	0.000
1.2000	0.053	0.046	0.107	0.000
1.2222	0.053	0.047	0.108	0.000
1.2444	0.053	0.048	0.109	0.000
1.2667	0.053	0.049	0.110	0.000
1.2889	0.053	0.050	0.111	0.000
1.3111	0.053	0.051	0.112	0.000
1.3333	0.053	0.051	0.113	0.000
1.3556	0.053	0.052	0.114	0.000
1.3778	0.053	0.053	0.115	0.000
1.4000	0.053	0.054	0.115	0.000
1.4222	0.053	0.055	0.116	0.000
1.4444	0.053	0.056	0.117	0.000
1.4667	0.053	0.057	0.118	0.000
1.4889	0.053	0.057	0.119	0.000
1.5111	0.053	0.058	0.120	0.000
1.5333	0.053	0.059	0.121	0.000
1.5556	0.053	0.060	0.122	0.000
1.5778	0.053	0.061	0.123	0.000
1.6000	0.053	0.062	0.123	0.000
1.6222	0.053	0.063	0.127	0.000
1.6444	0.053	0.063	0.134	0.000
1.6667	0.053	0.064	0.141	0.000
1.6889	0.053	0.065	0.151	0.000
1.7111	0.053	0.066	0.161	0.000
1.7333	0.053	0.067	0.172	0.000
1.7556	0.053	0.068	0.185	0.000
1.7778	0.053	0.069	0.198	0.000
1.8000	0.053	0.070	0.211	0.000
1.8222	0.053	0.070	0.226	0.000
1.8444	0.053	0.071	0.241	0.000
1.8667	0.053	0.072	0.257	0.000
1.8889	0.053	0.073	0.274	0.000
1.9111	0.053	0.074	0.291	0.000

1.9333	0.053	0.075	0.309	0.000
1.9556	0.053	0.076	0.327	0.000
1.9778	0.053	0.076	0.346	0.000
2.0000	0.053	0.077	0.366	0.000

Analysis Results

POC 1

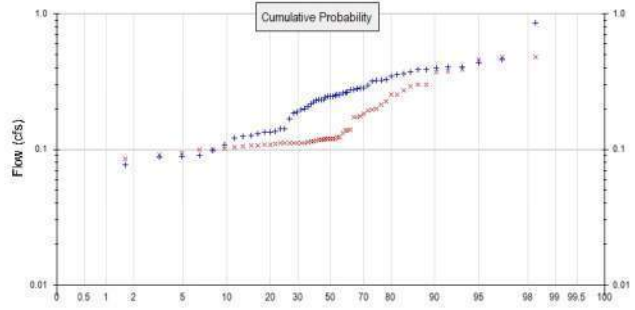
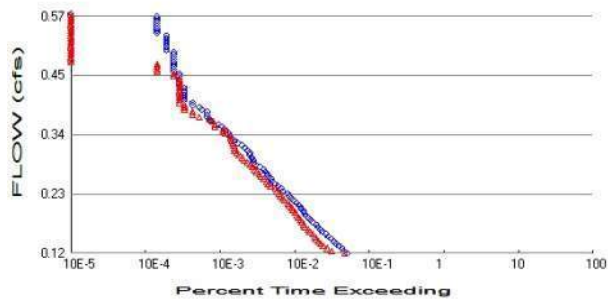

+ Predeveloped x Mitigated

Predeveloped Landuse Totals for POC #1

Total Pervious Area: 0.9478
 Total Impervious Area: 0

Mitigated Landuse Totals for POC #1

Total Pervious Area: 0.2051
 Total Impervious Area: 0.7427

Flow Frequency Method: Log Pearson Type III 17B

Flow Frequency Return Periods for Predeveloped. POC #1

Return Period	Flow(cfs)
2 year	0.237792
5 year	0.372265
10 year	0.445639
25 year	0.520497
50 year	0.565063
100 year	0.601747

Flow Frequency Return Periods for Mitigated. POC #1

Return Period	Flow(cfs)
2 year	0.143408
5 year	0.220762
10 year	0.285903
25 year	0.386617
50 year	0.47677
100 year	0.581482

Annual Peaks

Annual Peaks for Predeveloped and Mitigated. POC #1

Year	Predeveloped	Mitigated
1949	0.186	0.173
1950	0.243	0.118
1951	0.322	0.120
1952	0.189	0.184
1953	0.254	0.109
1954	0.354	0.113
1955	0.197	0.109
1956	0.387	0.374
1957	0.294	0.118
1958	0.218	0.302

1959	0.127	0.091
1960	0.125	0.123
1961	0.349	0.196
1962	0.234	0.111
1963	0.260	0.119
1964	0.248	0.112
1965	0.222	0.175
1966	0.284	0.118
1967	0.248	0.116
1968	0.324	0.119
1969	0.264	0.461
1970	0.862	0.476
1971	0.136	0.100
1972	0.232	0.111
1973	0.231	0.133
1974	0.364	0.388
1975	0.198	0.109
1976	0.285	0.123
1977	0.008	0.094
1978	0.406	0.254
1979	0.275	0.215
1980	0.168	0.104
1981	0.386	0.293
1982	0.260	0.274
1983	0.432	0.172
1984	0.141	0.107
1985	0.109	0.138
1986	0.134	0.114
1987	0.234	0.137
1988	0.090	0.106
1989	0.098	0.105
1990	0.089	0.100
1991	0.253	0.111
1992	0.278	0.099
1993	0.327	0.255
1994	0.250	0.193
1995	0.207	0.299
1996	0.397	0.477
1997	0.459	0.376
1998	0.371	0.120
1999	0.278	0.198
2000	0.134	0.085
2001	0.077	0.082
2002	0.405	0.114
2003	0.319	0.139
2004	0.087	0.112
2005	0.131	0.111
2006	0.245	0.111
2007	0.121	0.228
2008	0.142	0.120

Ranked Annual Peaks

Ranked Annual Peaks for Predeveloped and Mitigated. POC #1

Rank	Predeveloped	Mitigated
1	0.8622	0.4771
2	0.4595	0.4763
3	0.4322	0.4607
4	0.4060	0.3879

5	0.4054	0.3757
6	0.3967	0.3738
7	0.3870	0.3017
8	0.3860	0.2990
9	0.3714	0.2929
10	0.3637	0.2735
11	0.3544	0.2551
12	0.3485	0.2545
13	0.3270	0.2277
14	0.3237	0.2153
15	0.3216	0.1982
16	0.3187	0.1964
17	0.2943	0.1925
18	0.2848	0.1841
19	0.2841	0.1745
20	0.2782	0.1725
21	0.2776	0.1716
22	0.2748	0.1394
23	0.2638	0.1383
24	0.2598	0.1370
25	0.2598	0.1327
26	0.2543	0.1230
27	0.2529	0.1228
28	0.2500	0.1202
29	0.2480	0.1200
30	0.2476	0.1196
31	0.2446	0.1193
32	0.2435	0.1189
33	0.2343	0.1184
34	0.2338	0.1176
35	0.2319	0.1175
36	0.2309	0.1161
37	0.2223	0.1142
38	0.2183	0.1140
39	0.2075	0.1130
40	0.1982	0.1121
41	0.1973	0.1121
42	0.1885	0.1113
43	0.1857	0.1110
44	0.1681	0.1108
45	0.1421	0.1107
46	0.1410	0.1106
47	0.1364	0.1090
48	0.1344	0.1086
49	0.1343	0.1086
50	0.1308	0.1073
51	0.1269	0.1065
52	0.1254	0.1052
53	0.1211	0.1038
54	0.1087	0.1003
55	0.0983	0.0999
56	0.0905	0.0990
57	0.0892	0.0936
58	0.0875	0.0913
59	0.0775	0.0851
60	0.0078	0.0822

Duration Flows

The Facility PASSED

Flow(cfs)	Predev	Mit	Percentage	Pass/Fail
0.1189	1055	983	93	Pass
0.1234	965	655	67	Pass
0.1279	904	571	63	Pass
0.1324	818	507	61	Pass
0.1369	757	463	61	Pass
0.1414	699	434	62	Pass
0.1459	647	404	62	Pass
0.1504	587	388	66	Pass
0.1549	549	364	66	Pass
0.1595	490	333	67	Pass
0.1640	458	319	69	Pass
0.1685	429	291	67	Pass
0.1730	410	278	67	Pass
0.1775	367	263	71	Pass
0.1820	342	250	73	Pass
0.1865	317	236	74	Pass
0.1910	298	222	74	Pass
0.1955	281	213	75	Pass
0.2000	265	199	75	Pass
0.2045	254	192	75	Pass
0.2090	238	180	75	Pass
0.2135	225	169	75	Pass
0.2180	201	153	76	Pass
0.2226	187	146	78	Pass
0.2271	175	135	77	Pass
0.2316	169	129	76	Pass
0.2361	145	122	84	Pass
0.2406	139	115	82	Pass
0.2451	126	100	79	Pass
0.2496	114	92	80	Pass
0.2541	104	89	85	Pass
0.2586	101	80	79	Pass
0.2631	95	74	77	Pass
0.2676	90	71	78	Pass
0.2721	85	66	77	Pass
0.2766	81	61	75	Pass
0.2811	71	57	80	Pass
0.2856	62	53	85	Pass
0.2902	59	49	83	Pass
0.2947	58	44	75	Pass
0.2992	56	42	75	Pass
0.3037	53	38	71	Pass
0.3082	52	35	67	Pass
0.3127	49	33	67	Pass
0.3172	45	33	73	Pass
0.3217	41	32	78	Pass
0.3262	36	31	86	Pass
0.3307	33	30	90	Pass
0.3352	30	29	96	Pass
0.3397	28	29	103	Pass
0.3442	27	25	92	Pass
0.3487	25	23	92	Pass
0.3532	24	23	95	Pass

0.3578	22	18	81	Pass
0.3623	20	18	90	Pass
0.3668	16	17	106	Pass
0.3713	15	15	100	Pass
0.3758	14	11	78	Pass
0.3803	14	9	64	Pass
0.3848	14	9	64	Pass
0.3893	12	7	58	Pass
0.3938	11	7	63	Pass
0.3983	9	7	77	Pass
0.4028	9	6	66	Pass
0.4073	7	6	85	Pass
0.4118	7	6	85	Pass
0.4163	7	6	85	Pass
0.4208	7	6	85	Pass
0.4254	7	6	85	Pass
0.4299	7	6	85	Pass
0.4344	6	6	100	Pass
0.4389	6	6	100	Pass
0.4434	6	6	100	Pass
0.4479	6	6	100	Pass
0.4524	6	5	83	Pass
0.4569	6	5	83	Pass
0.4614	5	3	60	Pass
0.4659	5	3	60	Pass
0.4704	5	3	60	Pass
0.4749	5	3	60	Pass
0.4794	5	0	0	Pass
0.4839	5	0	0	Pass
0.4884	5	0	0	Pass
0.4930	5	0	0	Pass
0.4975	5	0	0	Pass
0.5020	4	0	0	Pass
0.5065	4	0	0	Pass
0.5110	4	0	0	Pass
0.5155	4	0	0	Pass
0.5200	4	0	0	Pass
0.5245	4	0	0	Pass
0.5290	4	0	0	Pass
0.5335	3	0	0	Pass
0.5380	3	0	0	Pass
0.5425	3	0	0	Pass
0.5470	3	0	0	Pass
0.5515	3	0	0	Pass
0.5560	3	0	0	Pass
0.5606	3	0	0	Pass
0.5651	3	0	0	Pass

Water Quality

Water Quality BMP Flow and Volume for POC #1

On-line facility volume: 0 acre-feet

On-line facility target flow: 0 cfs.

Adjusted for 15 min: 0 cfs.

Off-line facility target flow: 0 cfs.

Adjusted for 15 min: 0 cfs.

LID Report

LID Technique	Used for Treatment ?	Total Volume Needs Treatment (ac-ft)	Volume Through Facility (ac-ft)	Infiltration Volume (ac-ft)	Cumulative Volume Infiltration Credit	Percent Volume Infiltrated	Water Quality	Percent Water Quality Treated	Comment
Underground Detention POC	<input type="checkbox"/>	154.69			<input type="checkbox"/>	0.00			
Total Volume Infiltrated		154.69	0.00	0.00		0.00	0.00	0%	No Treat. Credit
Compliance with LID Standard 8% of 2-yr to 50% of 2-yr									Duration Analysis Result = Passed

Model Default Modifications

Total of 0 changes have been made.

PERLND Changes

No PERLND changes have been made.

IMPLND Changes

No IMPLND changes have been made.

Appendix
Predeveloped Schematic

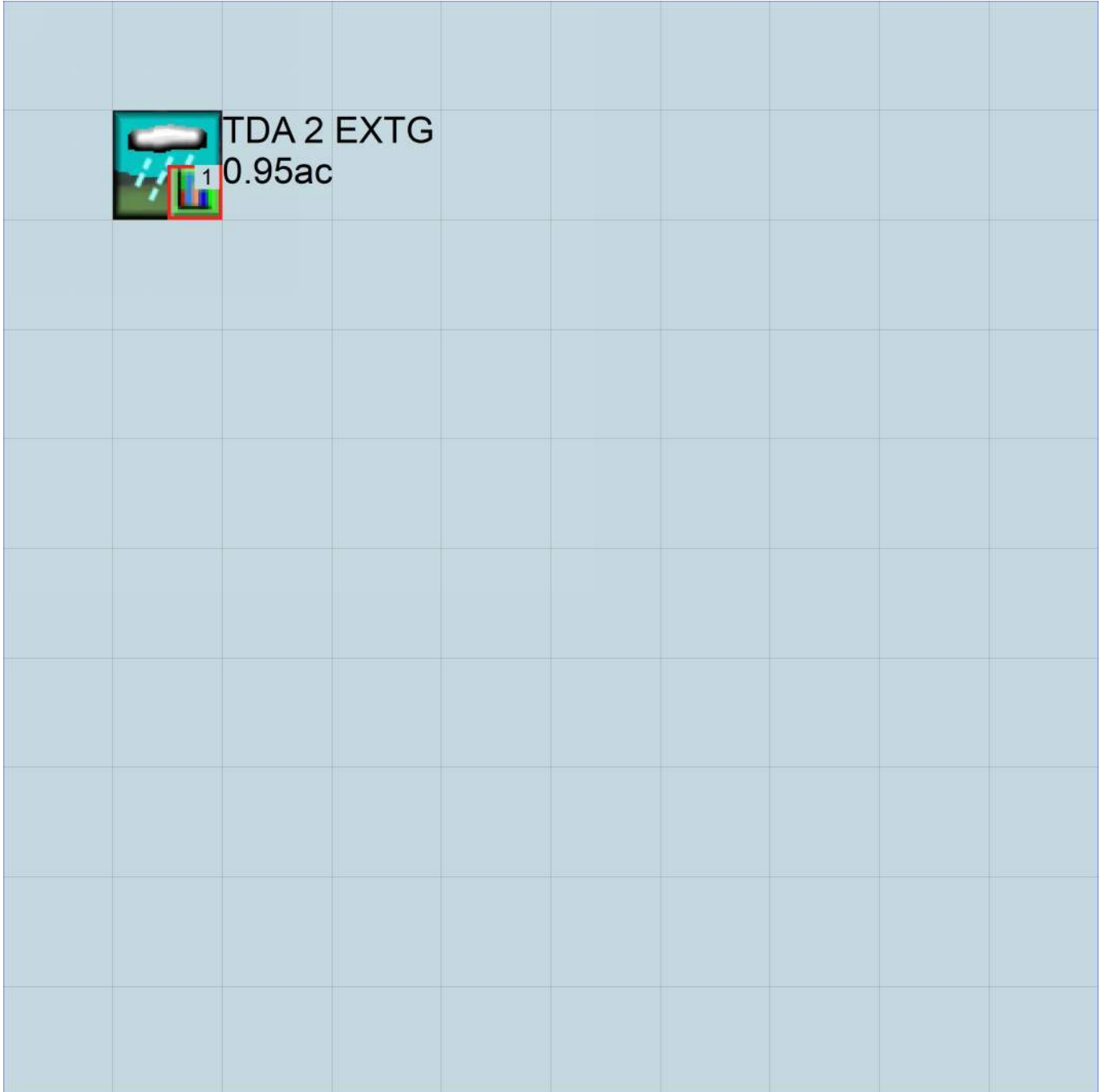

Mitigated Schematic

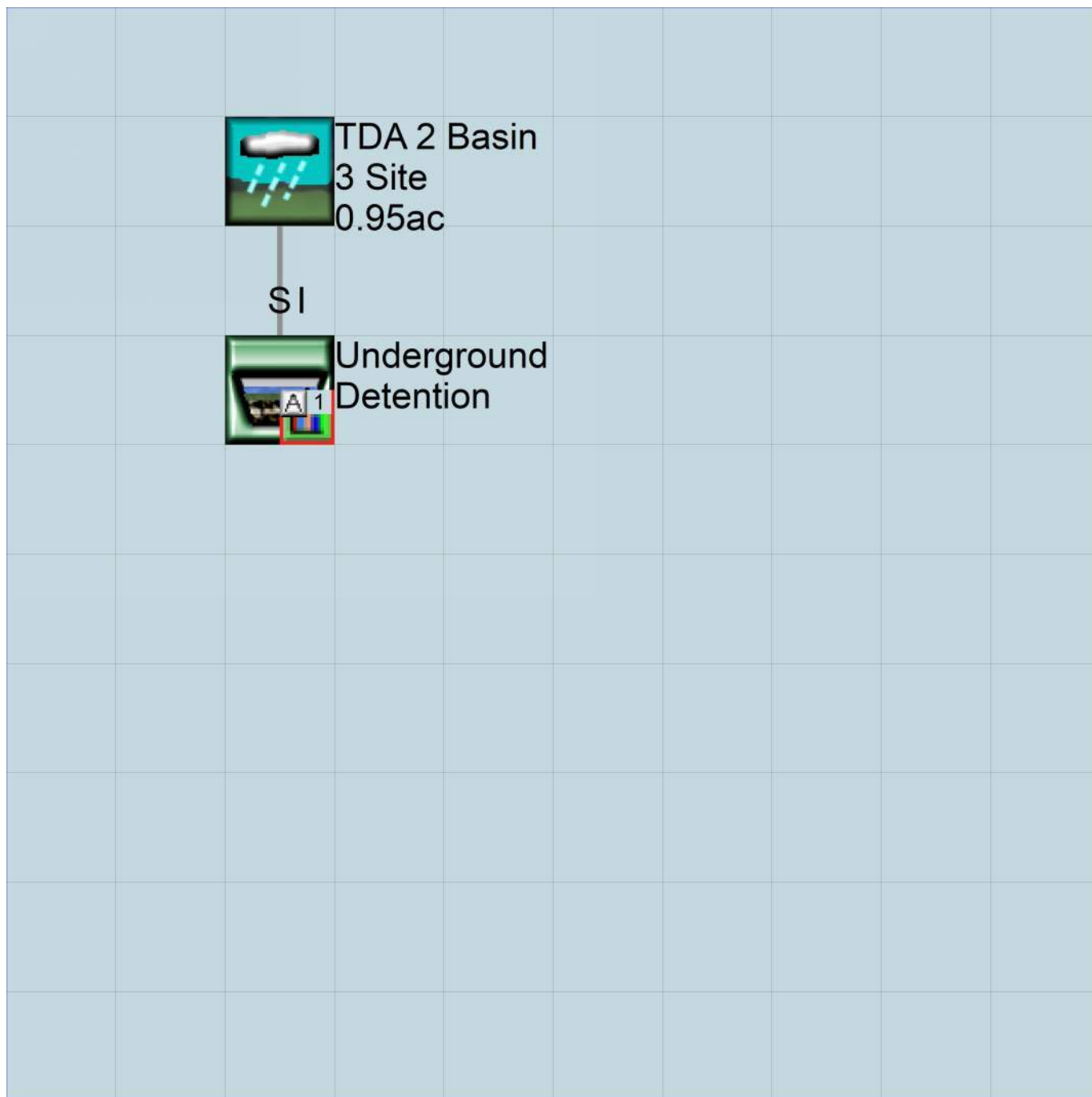

Predeveloped UCI File

RUN

GLOBAL

```

WVHM4 model simulation
START      1948 10 01      END      2008 09 30
RUN INTERP OUTPUT LEVEL   3      0
RESUME     0 RUN         1
UNIT SYSTEM                1
END GLOBAL

```

FILES

```

<File> <Un#> <-----File Name----->***
<-ID->                                     ***
WDM      26      13thPrelimStormAnalysis.wdm
MESSU    25      Prel3thPrelimStormAnalysis.MES
          27      Prel3thPrelimStormAnalysis.L61
          28      Prel3thPrelimStormAnalysis.L62
          30      POC13thPrelimStormAnalysis1.dat

```

END FILES

OPN SEQUENCE

```

INGRP                INDELT 00:15
  PERLND              28
  COPY                501
  DISPLY              1

```

END INGRP

END OPN SEQUENCE

DISPLY

DISPLY-INFO1

```

# - #<-----Title----->***TRAN PIVL DIG1 FIL1  PYR DIG2 FIL2 YRND
1      TDA 2 EXTG                MAX                1    2    30    9

```

END DISPLY-INFO1

END DISPLY

COPY

TIMESERIES

```

# - # NPT NMN ***
1      1    1
501    1    1

```

END TIMESERIES

END COPY

GENER

OPCODE

```

#      # OPCD ***

```

END OPCODE

PARM

```

#      #          K ***

```

END PARM

END GENER

PERLND

GEN-INFO

```

<PLS ><-----Name----->NBLKS  Unit-systems  Printer ***
# - #                               User  t-series  Engl Metr ***
                               in  out      ***

```

```

28      SG4, Forest, Flat      1    1    1    1    27    0

```

END GEN-INFO

```

*** Section PWATER***

```

ACTIVITY

```

<PLS > ***** Active Sections *****
# - # ATMP SNOW PWAT  SED  PST  PWG  PQAL MSTL PEST NITR PHOS TRAC ***
28      0    0    1    0    0    0    0    0    0    0    0    0

```

END ACTIVITY

PRINT-INFO

```

<PLS > ***** Print-flags ***** PIVL  PYR
# - # ATMP SNOW PWAT  SED  PST  PWG  PQAL MSTL PEST NITR PHOS TRAC *****
28      0    0    4    0    0    0    0    0    0    0    0    0    1    9

```

END PRINT-INFO

```

PWAT-PARM1
<PLS > PWATER variable monthly parameter value flags ***
# - # CSNO RTOP UZFG VCS VUZ VNN VIFW VIRC VLE INFC HWT ***
28 0 0 0 0 0 0 0 0 0 0 0
END PWAT-PARM1

PWAT-PARM2
<PLS > PWATER input info: Part 2 ***
# - # ***FOREST LZSN INFILF LSUR SLSUR KVARY AGWRC
28 0 6 0.04 400 0.05 0 0.96
END PWAT-PARM2

PWAT-PARM3
<PLS > PWATER input info: Part 3 ***
# - # ***PETMAX PETMIN INFEXP INFILD DEEPFR BASETP AGWETP
28 0 0 3 2 0 0 0
END PWAT-PARM3

PWAT-PARM4
<PLS > PWATER input info: Part 4 ***
# - # CEPSC UZSN NSUR INTFW IRC LZETP ***
28 0.2 0.4 0.35 2 0.4 0.7
END PWAT-PARM4

PWAT-STATE1
<PLS > *** Initial conditions at start of simulation
ran from 1990 to end of 1992 (pat 1-11-95) RUN 21 ***
# - # *** CEPS SURS UZS IFWS LZS AGWS GWVS
28 0 0 0 0 2.5 1 0
END PWAT-STATE1

END PERLND

IMPLND
GEN-INFO
<PLS ><-----Name-----> Unit-systems Printer ***
# - # User t-series Engl Metr ***
in out ***
END GEN-INFO
*** Section IWATER***

ACTIVITY
<PLS > ***** Active Sections *****
# - # ATMP SNOW IWAT SLD IWG IQAL ***
END ACTIVITY

PRINT-INFO
<ILS > ***** Print-flags ***** PIVL PYR
# - # ATMP SNOW IWAT SLD IWG IQAL *****
END PRINT-INFO

IWAT-PARM1
<PLS > IWATER variable monthly parameter value flags ***
# - # CSNO RTOP VRS VNN RTLI ***
END IWAT-PARM1

IWAT-PARM2
<PLS > IWATER input info: Part 2 ***
# - # *** LSUR SLSUR NSUR RETSC
END IWAT-PARM2

IWAT-PARM3
<PLS > IWATER input info: Part 3 ***
# - # ***PETMAX PETMIN
END IWAT-PARM3

IWAT-STATE1
<PLS > *** Initial conditions at start of simulation
# - # *** RETS SURS
END IWAT-STATE1

```



```

WDM      1 EVAP      ENGL      0.8          PERLND   1 999 EXTNL  PETINP
WDM      1 EVAP      ENGL      0.8          IMPLND   1 999 EXTNL  PETINP

```

END EXT SOURCES

EXT TARGETS

```

<-Volume-> <-Grp> <-Member-><--Mult-->Tran <-Volume-> <Member> Tsys Tgap Amd ***
<Name>      #      <Name> # #<-factor->strg <Name>      # <Name>      tem strg strg***
COPY  501 OUTPUT MEAN  1 1      48.4      WDM  501 FLOW      ENGL      REPL
END EXT TARGETS

```

MASS-LINK

```

<Volume>   <-Grp> <-Member-><--Mult-->      <Target>      <-Grp> <-Member->***
<Name>     #      <Name> # #<-factor->      <Name>      <Name> # #***
MASS-LINK  12
PERLND     PWATER SURO      0.083333      COPY      INPUT  MEAN
END MASS-LINK  12

```

```

MASS-LINK  13
PERLND     PWATER IFWO      0.083333      COPY      INPUT  MEAN
END MASS-LINK  13

```

END MASS-LINK

END RUN

Mitigated UCI File

RUN

GLOBAL

```

WVHM4 model simulation
START      1948 10 01      END      2008 09 30
RUN INTERP OUTPUT LEVEL   3      0
RESUME     0 RUN          1
UNIT SYSTEM                1
END GLOBAL

```

FILES

```

<File>  <Un#>  <-----File Name----->***
<-ID->                                     ***
WDM      26     13thPrelimStormAnalysis.wdm
MESSU    25     Mit13thPrelimStormAnalysis.MES
          27     Mit13thPrelimStormAnalysis.L61
          28     Mit13thPrelimStormAnalysis.L62
          30     POC13thPrelimStormAnalysis1.dat

```

END FILES

OPN SEQUENCE

```

INGRP          INDELT 00:15
  PERLND       34
  IMPLND        1
  IMPLND        4
  IMPLND        8
  RCHRES        1
  COPY          1
  COPY         501
  DISPLY        1

```

END INGRP

END OPN SEQUENCE

DISPLY

DISPLY-INF01

```

# - #<-----Title----->***TRAN PIVL DIG1 FIL1  PYR DIG2 FIL2 YRND
1      Underground Detention      MAX      1      2      30      9

```

END DISPLY-INF01

END DISPLY

COPY

TIMESERIES

```

# - # NPT NMN ***
1      1      1
501    1      1

```

END TIMESERIES

END COPY

GENER

OPCODE

```

#      # OPCD ***

```

END OPCODE

PARM

```

#      #          K ***

```

END PARM

END GENER

PERLND

GEN-INFO

```

<PLS ><-----Name----->NBLKS  Unit-systems  Printer ***
# - #          User  t-series  Engl Metr ***
          in  out          ***
34      SG4, Lawn, Flat      1      1      1      1      27      0

```

END GEN-INFO

*** Section PWATER***

ACTIVITY

```

<PLS > ***** Active Sections *****
# - # ATMP SNOW PWAT  SED  PST  PWG  PQAL MSTL  PEST  NITR  PHOS  TRAC ***
34      0      0      1      0      0      0      0      0      0      0      0      0

```

END ACTIVITY

PRINT-INFO

```

<PLS > ***** Print-flags ***** PIVL  PYR
# - # ATMP SNOW PWAT  SED  PST  PWG  PQAL MSTL PEST NITR PHOS TRAC  *****
34  0  0  4  0  0  0  0  0  0  0  0  0  0  1  9
END PRINT-INFO

```

```

PWAT-PARM1
<PLS > PWATER variable monthly parameter value flags ***
# - # CSNO RTOP UZFG  VCS  VUZ  VNN VIFW VIRG  VLE INFC  HWT ***
34  0  0  0  0  0  0  0  0  0  0  0  0
END PWAT-PARM1

```

```

PWAT-PARM2
<PLS > PWATER input info: Part 2 *****
# - # ***FOREST  LZSN  INFILT  LSUR  SLSUR  KVARY  AGWRC
34  0  6  0.02  400  0.05  0  0.96
END PWAT-PARM2

```

```

PWAT-PARM3
<PLS > PWATER input info: Part 3 *****
# - # ***PETMAX  PETMIN  INFEXP  INFILD  DEEPFR  BASETP  AGWETP
34  0  0  3  2  0  0  0
END PWAT-PARM3

```

```

PWAT-PARM4
<PLS > PWATER input info: Part 4 *****
# - # CEPSC  UZSN  NSUR  INTFW  IRC  LZETP ***
34  0.1  0.2  0.25  2  0.4  0.25
END PWAT-PARM4

```

```

PWAT-STATE1
<PLS > *** Initial conditions at start of simulation
ran from 1990 to end of 1992 (pat 1-11-95) RUN 21 ***
# - # *** CEPS  SURS  UZS  IFWS  LZS  AGWS  GWVS
34  0  0  0  0  2.5  1  0
END PWAT-STATE1

```

END PERLND

IMPLND

```

GEN-INFO
<PLS ><-----Name----->  Unit-systems  Printer ***
# - #  User t-series Engl Metr ***
      in out ***
1  ROADS/FLAT  1  1  1  27  0
4  ROOF TOPS/FLAT  1  1  1  27  0
8  SIDEWALKS/FLAT  1  1  1  27  0
END GEN-INFO
*** Section IWATER***

```

```

ACTIVITY
<PLS > ***** Active Sections *****
# - # ATMP SNOW IWAT  SLD  IWG IQAL  ***
1  0  0  1  0  0  0
4  0  0  1  0  0  0
8  0  0  1  0  0  0
END ACTIVITY

```

```

PRINT-INFO
<ILS > ***** Print-flags ***** PIVL  PYR
# - # ATMP SNOW IWAT  SLD  IWG IQAL  *****
1  0  0  4  0  0  4  1  9
4  0  0  4  0  0  0  1  9
8  0  0  4  0  0  0  1  9
END PRINT-INFO

```

```

IWAT-PARM1
<PLS > IWATER variable monthly parameter value flags ***
# - # CSNO RTOP VRS  VNN RTLI  ***
1  0  0  0  0  0
4  0  0  0  0  0
8  0  0  0  0  0

```

END IWAT-PARM1

IWAT-PARM2

```
<PLS > IWATER input info: Part 2 ***
# - # *** LSUR SLSUR NSUR RETSC
1 400 0.01 0.1 0.1
4 400 0.01 0.1 0.1
8 400 0.01 0.1 0.1
```

END IWAT-PARM2

IWAT-PARM3

```
<PLS > IWATER input info: Part 3 ***
# - # ***PETMAX PETMIN
1 0 0
4 0 0
8 0 0
```

END IWAT-PARM3

IWAT-STATE1

```
<PLS > *** Initial conditions at start of simulation
# - # *** RETS SURS
1 0 0
4 0 0
8 0 0
```

END IWAT-STATE1

END IMPLND

SCHEMATIC

<-Source->	<--Area-->	<-Target->	MBLK	***
<Name> #	<-factor->	<Name> #	Tbl#	***
TDA 2 Basin 3 Site***				
PERLND 34	0.2051	RCHRES 1	2	
PERLND 34	0.2051	RCHRES 1	3	
IMPLND 1	0.5074	RCHRES 1	5	
IMPLND 4	0.1781	RCHRES 1	5	
IMPLND 8	0.0572	RCHRES 1	5	

*****Routing*****

PERLND 34	0.2051	COPY 1	12
IMPLND 1	0.5074	COPY 1	15
IMPLND 4	0.1781	COPY 1	15
IMPLND 8	0.0572	COPY 1	15
PERLND 34	0.2051	COPY 1	13
RCHRES 1	1	COPY 501	16

END SCHEMATIC

NETWORK

```
<-Volume-> <-Grp> <-Member-><--Mult-->Tran <-Target vols> <-Grp> <-Member-> ***
<Name> # <Name> # #<-factor->strg <Name> # # <Name> # # ***
COPY 501 OUTPUT MEAN 1 1 48.4 DISPLY 1 INPUT TIMSER 1
```

```
<-Volume-> <-Grp> <-Member-><--Mult-->Tran <-Target vols> <-Grp> <-Member-> ***
<Name> # <Name> # #<-factor->strg <Name> # # <Name> # # ***
END NETWORK
```

RCHRES

GEN-INFO

RCHRES	Name	Nexits	Unit	Systems	Printer	***
# - #	<-----><----->	User	T-series	Engl Metr	LKFG	***
			in out			***
1	Underground Dete-016	1	1	1 1	28 0	1

END GEN-INFO

*** Section RCHRES***

ACTIVITY

```
<PLS > ***** Active Sections *****
# - # HYFG ADFG CNFG HTFG SDFG GQFG OXFG NUFG PKFG PHFG ***
```



```

0.711111 0.053076 0.027651 0.082610
0.733333 0.053076 0.028515 0.083891
0.755556 0.053076 0.029379 0.085153
0.777778 0.053076 0.030243 0.086396
0.800000 0.053076 0.031107 0.087622
0.822222 0.053076 0.031971 0.088830
0.844444 0.053076 0.032835 0.090023
0.866667 0.053076 0.033699 0.091199
0.888889 0.053076 0.034563 0.092361
0.911111 0.053076 0.035427 0.093509
0.933333 0.053076 0.036291 0.094642
0.955556 0.053076 0.037155 0.095762
0.977778 0.053076 0.038020 0.096869
1.000000 0.053076 0.038884 0.097964
1.022222 0.053076 0.039748 0.099046
1.044444 0.053076 0.040612 0.100117
1.066667 0.053076 0.041476 0.101177
1.088889 0.053076 0.042340 0.102225
1.111111 0.053076 0.043204 0.103263
1.133333 0.053076 0.044068 0.104291
1.155556 0.053076 0.044932 0.105308
1.177778 0.053076 0.045796 0.106316
1.200000 0.053076 0.046660 0.107314
1.222222 0.053076 0.047524 0.108303
1.244444 0.053076 0.048389 0.109283
1.266667 0.053076 0.049253 0.110255
1.288889 0.053076 0.050117 0.111218
1.311111 0.053076 0.050981 0.112172
1.333333 0.053076 0.051845 0.113119
1.355556 0.053076 0.052709 0.114058
1.377778 0.053076 0.053573 0.114989
1.400000 0.053076 0.054437 0.115912
1.422222 0.053076 0.055301 0.116829
1.444444 0.053076 0.056165 0.117738
1.466667 0.053076 0.057029 0.118640
1.488889 0.053076 0.057893 0.119536
1.511111 0.053076 0.058757 0.120424
1.533333 0.053076 0.059622 0.121307
1.555556 0.053076 0.060486 0.122182
1.577778 0.053076 0.061350 0.123052
1.600000 0.053076 0.062214 0.123916
1.622222 0.053076 0.063078 0.124782
1.644444 0.053076 0.063942 0.125649
1.666667 0.053076 0.064806 0.126516
1.688889 0.053076 0.065670 0.127382
1.711111 0.053076 0.066534 0.128249
1.733333 0.053076 0.067398 0.129116
1.755556 0.053076 0.068262 0.130000
1.777778 0.053076 0.069126 0.130867
1.800000 0.053076 0.069991 0.131734
1.822222 0.053076 0.070855 0.132600
1.844444 0.053076 0.071719 0.133467
1.866667 0.053076 0.072583 0.134334
1.888889 0.053076 0.073447 0.135200
1.911111 0.053076 0.074311 0.136067
1.933333 0.053076 0.075175 0.136934
1.955556 0.053076 0.076039 0.137800
1.977778 0.053076 0.076903 0.138667
2.000000 0.053076 0.077767 0.139534
2.022222 0.053076 0.078631 0.140400

```

```

END FTABLE 1
END FTABLES

```

EXT SOURCES

```

<-Volume-> <Member> SsysSgap<--Mult-->Tran <-Target vols> <-Grp> <-Member-> ***
<Name> # <Name> # tem strg<-factor->strg <Name> # # <Name> # # ***
WDM 2 PREC ENGL 1.3 PERLND 1 999 EXTNL PREC
WDM 2 PREC ENGL 1.3 IMPLND 1 999 EXTNL PREC
WDM 1 EVAP ENGL 0.8 PERLND 1 999 EXTNL PETINP
WDM 1 EVAP ENGL 0.8 IMPLND 1 999 EXTNL PETINP

```

END EXT SOURCES

EXT TARGETS

<-Volume->	<-Grp>	<-Member->	<--Mult-->	Tran	<-Volume->	<Member>	Tsys	Tgap	Amd	***	
<Name>	#	<Name>	#	#<-factor-->	strg	<Name>	#	<Name>	tem	strg	strg***
RCHRES	1	HYDR	RO	1 1	1	WDM	1000	FLOW	ENGL		REPL
RCHRES	1	HYDR	STAGE	1 1	1	WDM	1001	STAG	ENGL		REPL
COPY	1	OUTPUT	MEAN	1 1	48.4	WDM	701	FLOW	ENGL		REPL
COPY	501	OUTPUT	MEAN	1 1	48.4	WDM	801	FLOW	ENGL		REPL

END EXT TARGETS

MASS-LINK

<Volume>	<-Grp>	<-Member->	<--Mult-->	<Target>	<-Grp>	<-Member->	***
<Name>	#	<Name>	#	#<-factor-->	<Name>	#	#***
MASS-LINK		2					
PERLND	PWATER	SURO		0.083333	RCHRES	INFLOW	IVOL
END MASS-LINK		2					
MASS-LINK		3					
PERLND	PWATER	IFWO		0.083333	RCHRES	INFLOW	IVOL
END MASS-LINK		3					
MASS-LINK		5					
IMPLND	IWATER	SURO		0.083333	RCHRES	INFLOW	IVOL
END MASS-LINK		5					
MASS-LINK		12					
PERLND	PWATER	SURO		0.083333	COPY	INPUT	MEAN
END MASS-LINK		12					
MASS-LINK		13					
PERLND	PWATER	IFWO		0.083333	COPY	INPUT	MEAN
END MASS-LINK		13					
MASS-LINK		15					
IMPLND	IWATER	SURO		0.083333	COPY	INPUT	MEAN
END MASS-LINK		15					
MASS-LINK		16					
RCHRES	ROFLOW				COPY	INPUT	MEAN
END MASS-LINK		16					

END MASS-LINK

END RUN

Predeveloped HSPF Message File

Mitigated HSPF Message File

ERROR/WARNING ID: 341 6

DATE/TIME: 1969/ 9/17 21:30

RCHRES: 1

The volume of water in this reach/mixed reservoir is greater than the value in the "volume" column of the last row of RCHTAB(). To continue the simulation the table has been extrapolated, based on information contained in the last two rows. This will usually result in some loss of accuracy. If depth is being calculated it will also cause an error condition. Relevant data are:

NROWS	V1	V2	VOL
92 3387.5	3438.9	3471.8	

ERROR/WARNING ID: 341 5

DATE/TIME: 1969/ 9/17 21:30

RCHRES: 1

Calculation of relative depth, using Newton's method of successive approximations, converged to an invalid value (not in range 0.0 to 1.0). Probably ftable was extrapolated. If extrapolation was small, no problem. Remedy; extend ftable. Relevant data are:

A	B	C	RDEP1	RDEP2	COUNT
0.0000E+00	4624.0	-7.584E+03	1.6401	1.6401E+00	2

ERROR/WARNING ID: 341 6

DATE/TIME: 1969/ 9/17 21:45

RCHRES: 1

The volume of water in this reach/mixed reservoir is greater than the value in the "volume" column of the last row of RCHTAB(). To continue the simulation the table has been extrapolated, based on information contained in the last two rows. This will usually result in some loss of accuracy. If depth is being calculated it will also cause an error condition. Relevant data are:

NROWS	V1	V2	VOL
92 3.3875E+03	3438.9	3616.7	

ERROR/WARNING ID: 341 5

DATE/TIME: 1969/ 9/17 21:45

RCHRES: 1

Calculation of relative depth, using Newton's method of successive approximations, converged to an invalid value (not in range 0.0 to 1.0). Probably ftable was extrapolated. If extrapolation was small, no problem. Remedy; extend ftable. Relevant data are:

A	B	C	RDEP1	RDEP2	COUNT
0.0000E+00	4624.0	-2.061E+04	4.4577	4.4577E+00	2

ERROR/WARNING ID: 341 6

DATE/TIME: 1969/ 9/17 22: 0

RCHRES: 1

The volume of water in this reach/mixed reservoir is greater than the value in the "volume" column of the last row of RCHTAB(). To continue the simulation the table has been extrapolated, based on information contained in the last two rows. This will usually result in some loss of accuracy. If depth is being calculated it will also cause an error condition.
Relevant data are:

NROWS	V1	V2	VOL
92	3.3875E+03	3438.9	3482.2

ERROR/WARNING ID: 341 5

DATE/TIME: 1969/ 9/17 22: 0

RCHRES: 1

Calculation of relative depth, using Newton's method of successive approximations, converged to an invalid value (not in range 0.0 to 1.0). Probably ftable was extrapolated. If extrapolation was small, no problem. Remedy; extend ftable. Relevant data are:

A	B	C	RDEP1	RDEP2	COUNT
0.0000E+00	4624.0	-8.521E+03	1.8427	1.8427E+00	2

ERROR/WARNING ID: 341 6

DATE/TIME: 1970/ 1/22 17: 0

RCHRES: 1

The volume of water in this reach/mixed reservoir is greater than the value in the "volume" column of the last row of RCHTAB(). To continue the simulation the table has been extrapolated, based on information contained in the last two rows. This will usually result in some loss of accuracy. If depth is being calculated it will also cause an error condition.
Relevant data are:

NROWS	V1	V2	VOL
92	3.3875E+03	3438.9	3565.4

ERROR/WARNING ID: 341 5

DATE/TIME: 1970/ 1/22 17: 0

RCHRES: 1

Calculation of relative depth, using Newton's method of successive approximations, converged to an invalid value (not in range 0.0 to 1.0). Probably ftable was extrapolated. If extrapolation was small, no problem. Remedy; extend ftable. Relevant data are:

A	B	C	RDEP1	RDEP2	COUNT
0.0000E+00	4624.0	-1.600E+04	3.4612	3.4611E+00	2

ERROR/WARNING ID: 341 6

DATE/TIME: 1970/ 1/22 17:15

RCHRES: 1

The volume of water in this reach/mixed reservoir is greater than the value in the "volume" column of the last row of RCHTAB(). To continue the simulation the table has been extrapolated, based on information contained in the last two rows. This will usually result in some loss of accuracy. If depth is being calculated it will also cause an error condition.
Relevant data are:

NROWS	V1	V2	VOL
92	3.3875E+03	3438.9	3586.9

ERROR/WARNING ID: 341 5

DATE/TIME: 1970/ 1/22 17:15

RCHRES: 1

Calculation of relative depth, using Newton's method of successive approximations, converged to an invalid value (not in range 0.0 to 1.0). Probably ftable was extrapolated. If extrapolation was small, no problem. Remedy; extend ftable. Relevant data are:

A	B	C	RDEP1	RDEP2	COUNT	
0.0000E+00	4624.0	-1.794E+04	3.8796	3.8796E+00	2	

ERROR/WARNING ID: 341 6

DATE/TIME: 1970/ 1/22 17:30

RCHRES: 1

The volume of water in this reach/mixed reservoir is greater than the value in the "volume" column of the last row of RCHTAB(). To continue the simulation the table has been extrapolated, based on information contained in the last two rows. This will usually result in some loss of accuracy. If depth is being calculated it will also cause an error condition. Relevant data are:

NROWS	V1	V2	VOL
92	3.3875E+03	3438.9	3469.4

ERROR/WARNING ID: 341 5

DATE/TIME: 1970/ 1/22 17:30

RCHRES: 1

Calculation of relative depth, using Newton's method of successive approximations, converged to an invalid value (not in range 0.0 to 1.0). Probably ftable was extrapolated. If extrapolation was small, no problem. Remedy; extend ftable. Relevant data are:

A	B	C	RDEP1	RDEP2	COUNT	
0.0000E+00	4624.0	-7.362E+03	1.5922	1.5922E+00	2	

ERROR/WARNING ID: 341 6

DATE/TIME: 1995/11/11 6:15

RCHRES: 1

The volume of water in this reach/mixed reservoir is greater than the value in the "volume" column of the last row of RCHTAB(). To continue the simulation the table has been extrapolated, based on information contained in the last two rows. This will usually result in some loss of accuracy. If depth is being calculated it will also cause an error condition. Relevant data are:

NROWS	V1	V2	VOL
92	3.3875E+03	3438.9	3511.1

ERROR/WARNING ID: 341 5

DATE/TIME: 1995/11/11 6:15

RCHRES: 1

Calculation of relative depth, using Newton's method of successive approximations, converged to an invalid value (not in range 0.0 to 1.0).

Probably ftable was extrapolated. If extrapolation was small, no problem.
Remedy; extend ftable. Relevant data are:

A	B	C	RDEP1	RDEP2	COUNT	
0.0000E+00	4624.0	-1.112E+04	2.4041	2.4041	2.4041	2

ERROR/WARNING ID: 341 6

DATE/TIME: 1995/11/11 6:30

RCHRES: 1

The volume of water in this reach/mixed reservoir is greater than the value in the "volume" column of the last row of RCHTAB(). To continue the simulation the table has been extrapolated, based on information contained in the last two rows. This will usually result in some loss of accuracy. If depth is being calculated it will also cause an error condition.
Relevant data are:

NROWS	V1	V2	VOL
92 3387.5	3438.9	3643.9	

ERROR/WARNING ID: 341 5

DATE/TIME: 1995/11/11 6:30

RCHRES: 1

Calculation of relative depth, using Newton's method of successive approximations, converged to an invalid value (not in range 0.0 to 1.0). Probably ftable was extrapolated. If extrapolation was small, no problem.
Remedy; extend ftable. Relevant data are:

A	B	C	RDEP1	RDEP2	COUNT	
0.0000E+00	4624.0	-2.307E+04	4.9884	4.9884E+00	4.9884E+00	2

ERROR/WARNING ID: 341 6

DATE/TIME: 1995/11/11 6:45

RCHRES: 1

The volume of water in this reach/mixed reservoir is greater than the value in the "volume" column of the last row of RCHTAB(). To continue the simulation the table has been extrapolated, based on information contained in the last two rows. This will usually result in some loss of accuracy. If depth is being calculated it will also cause an error condition.
Relevant data are:

NROWS	V1	V2	VOL
92 3.3875E+03	3438.9	3511.3	

ERROR/WARNING ID: 341 5

DATE/TIME: 1995/11/11 6:45

RCHRES: 1

Calculation of relative depth, using Newton's method of successive approximations, converged to an invalid value (not in range 0.0 to 1.0). Probably ftable was extrapolated. If extrapolation was small, no problem.
Remedy; extend ftable. Relevant data are:

A	B	C	RDEP1	RDEP2	COUNT	
0.0000E+00	4624.0	-1.113E+04	2.4071	2.4071E+00	2.4071E+00	2

Disclaimer

Legal Notice

This program and accompanying documentation are provided 'as-is' without warranty of any kind. The entire risk regarding the performance and results of this program is assumed by End User. Clear Creek Solutions Inc. and the governmental licensee or sublicensees disclaim all warranties, either expressed or implied, including but not limited to implied warranties of program and accompanying documentation. In no event shall Clear Creek Solutions Inc. be liable for any damages whatsoever (including without limitation to damages for loss of business profits, loss of business information, business interruption, and the like) arising out of the use of, or inability to use this program even if Clear Creek Solutions Inc. or their authorized representatives have been advised of the possibility of such damages. Software Copyright © by : Clear Creek Solutions, Inc. 2005-2023; All Rights Reserved.

Clear Creek Solutions, Inc.
6200 Capitol Blvd. Ste F
Olympia, WA. 98501
Toll Free 1(866)943-0304
Local (360)943-0304

www.clearcreeksolutions.com

SEPARATOR SHEET

WWHM2012
PROJECT REPORT

General Model Information

Project Name: 13thPrelimTreatmentAnalysis
Site Name: 13th Gas Station
Site Address:
City:
Report Date: 8/22/2023
Gage: Lacamas
Data Start: 1948/10/01
Data End: 2008/09/30
Timestep: 15 Minute
Precip Scale: 1.300
Version Date: 2018/10/10
Version: 4.2.16

POC Thresholds

Low Flow Threshold for POC1:	50 Percent of the 2 Year
High Flow Threshold for POC1:	50 Year

Landuse Basin Data

Predeveloped Land Use

TDA 2 Treatment

Bypass:	No
GroundWater:	No
Pervious Land Use	acre
SG4, Lawn, Flat	0.2916
Pervious Total	0.2916
Impervious Land Use	acre
ROADS FLAT	0.6565
ROOF TOPS FLAT	0.1781
SIDEWALKS FLAT	0.0572
Impervious Total	0.8918
Basin Total	1.1834

Element Flows To:		
Surface	Interflow	Groundwater

*Mitigated Land Use***TDA 2 Treatment**

Bypass:	No
GroundWater:	No
Pervious Land Use	acre
SG4, Lawn, Flat	0.2916
Pervious Total	0.2916
Impervious Land Use	acre
ROADS FLAT	0.6565
ROOF TOPS FLAT	0.1781
SIDEWALKS FLAT	0.0572
Impervious Total	0.8918
Basin Total	1.1834

Element Flows To:		
Surface	Interflow	Groundwater

Routing Elements
Predeveloped Routing

Mitigated Routing

Analysis Results

POC 1

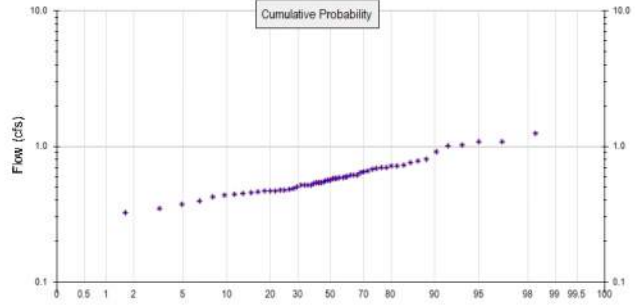
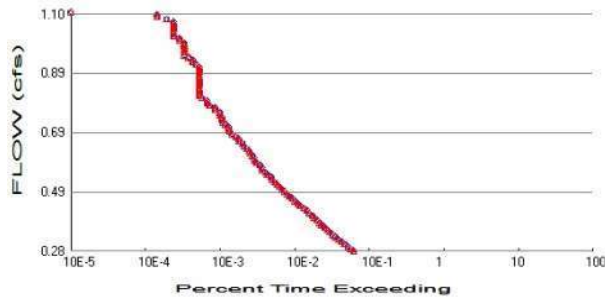

+ Predeveloped x Mitigated

Predeveloped Landuse Totals for POC #1

Total Pervious Area: 0.2916
 Total Impervious Area: 0.8918

Mitigated Landuse Totals for POC #1

Total Pervious Area: 0.2916
 Total Impervious Area: 0.8918

Flow Frequency Method: Log Pearson Type III 17B

Flow Frequency Return Periods for Predeveloped. POC #1

Return Period	Flow(cfs)
2 year	0.568841
5 year	0.733272
10 year	0.844412
25 year	0.987932
50 year	1.097315
100 year	1.208959

Flow Frequency Return Periods for Mitigated. POC #1

Return Period	Flow(cfs)
2 year	0.568841
5 year	0.733272
10 year	0.844412
25 year	0.987932
50 year	1.097315
100 year	1.208959

Annual Peaks

Annual Peaks for Predeveloped and Mitigated. POC #1

Year	Predeveloped	Mitigated
1949	0.762	0.762
1950	0.501	0.501
1951	0.537	0.537
1952	0.561	0.561
1953	0.520	0.520
1954	0.718	0.718
1955	0.437	0.437
1956	0.588	0.588
1957	0.612	0.612
1958	0.685	0.685

1959	0.460	0.460
1960	0.455	0.455
1961	0.560	0.560
1962	0.491	0.491
1963	0.592	0.592
1964	0.452	0.452
1965	0.467	0.467
1966	0.541	0.541
1967	0.558	0.558
1968	1.082	1.082
1969	0.918	0.918
1970	1.244	1.244
1971	0.483	0.483
1972	0.655	0.655
1973	0.534	0.534
1974	0.549	0.549
1975	0.395	0.395
1976	0.467	0.467
1977	0.289	0.289
1978	0.681	0.681
1979	0.779	0.779
1980	0.425	0.425
1981	0.644	0.644
1982	0.647	0.647
1983	0.724	0.724
1984	0.374	0.374
1985	0.470	0.470
1986	0.712	0.712
1987	0.444	0.444
1988	0.542	0.542
1989	0.611	0.611
1990	0.579	0.579
1991	0.610	0.610
1992	0.579	0.579
1993	0.693	0.693
1994	0.478	0.478
1995	0.589	0.589
1996	0.805	0.805
1997	1.019	1.019
1998	1.075	1.075
1999	0.477	0.477
2000	0.345	0.345
2001	0.323	0.323
2002	0.693	0.693
2003	0.518	0.518
2004	0.520	0.520
2005	0.596	0.596
2006	0.580	0.580
2007	0.514	0.514
2008	1.001	1.001

Ranked Annual Peaks

Ranked Annual Peaks for Predeveloped and Mitigated. POC #1

Rank	Predeveloped	Mitigated
1	1.2439	1.2439
2	1.0816	1.0816
3	1.0749	1.0749
4	1.0186	1.0186

5	1.0011	1.0011
6	0.9178	0.9178
7	0.8045	0.8045
8	0.7793	0.7793
9	0.7619	0.7619
10	0.7241	0.7241
11	0.7179	0.7179
12	0.7124	0.7124
13	0.6935	0.6935
14	0.6927	0.6927
15	0.6851	0.6851
16	0.6812	0.6812
17	0.6545	0.6545
18	0.6466	0.6466
19	0.6442	0.6442
20	0.6123	0.6123
21	0.6111	0.6111
22	0.6101	0.6101
23	0.5959	0.5959
24	0.5924	0.5924
25	0.5892	0.5892
26	0.5876	0.5876
27	0.5797	0.5797
28	0.5787	0.5787
29	0.5786	0.5786
30	0.5607	0.5607
31	0.5604	0.5604
32	0.5581	0.5581
33	0.5492	0.5492
34	0.5415	0.5415
35	0.5414	0.5414
36	0.5374	0.5374
37	0.5337	0.5337
38	0.5201	0.5201
39	0.5200	0.5200
40	0.5184	0.5184
41	0.5144	0.5144
42	0.5005	0.5005
43	0.4907	0.4907
44	0.4833	0.4833
45	0.4781	0.4781
46	0.4771	0.4771
47	0.4696	0.4696
48	0.4669	0.4669
49	0.4667	0.4667
50	0.4597	0.4597
51	0.4553	0.4553
52	0.4517	0.4517
53	0.4439	0.4439
54	0.4367	0.4367
55	0.4251	0.4251
56	0.3951	0.3951
57	0.3742	0.3742
58	0.3454	0.3454
59	0.3232	0.3232
60	0.2887	0.2887

Duration Flows

The Facility PASSED

Flow(cfs)	Predev	Mit	Percentage	Pass/Fail
0.2844	1293	1293	100	Pass
0.2926	1194	1194	100	Pass
0.3008	1088	1088	100	Pass
0.3091	977	977	100	Pass
0.3173	891	891	100	Pass
0.3255	805	805	100	Pass
0.3337	738	738	100	Pass
0.3419	682	682	100	Pass
0.3501	612	612	100	Pass
0.3583	573	573	100	Pass
0.3665	528	528	100	Pass
0.3747	489	489	100	Pass
0.3830	456	456	100	Pass
0.3912	414	414	100	Pass
0.3994	379	379	100	Pass
0.4076	360	360	100	Pass
0.4158	330	330	100	Pass
0.4240	304	304	100	Pass
0.4322	276	276	100	Pass
0.4404	248	248	100	Pass
0.4486	231	231	100	Pass
0.4569	214	214	100	Pass
0.4651	193	193	100	Pass
0.4733	179	179	100	Pass
0.4815	165	165	100	Pass
0.4897	154	154	100	Pass
0.4979	143	143	100	Pass
0.5061	130	130	100	Pass
0.5143	121	121	100	Pass
0.5225	114	114	100	Pass
0.5308	106	106	100	Pass
0.5390	101	101	100	Pass
0.5472	90	90	100	Pass
0.5554	86	86	100	Pass
0.5636	77	77	100	Pass
0.5718	76	76	100	Pass
0.5800	71	71	100	Pass
0.5882	64	64	100	Pass
0.5964	61	61	100	Pass
0.6047	60	60	100	Pass
0.6129	57	57	100	Pass
0.6211	53	53	100	Pass
0.6293	51	51	100	Pass
0.6375	48	48	100	Pass
0.6457	44	44	100	Pass
0.6539	42	42	100	Pass
0.6621	38	38	100	Pass
0.6703	37	37	100	Pass
0.6786	34	34	100	Pass
0.6868	30	30	100	Pass
0.6950	28	28	100	Pass
0.7032	27	27	100	Pass
0.7114	27	27	100	Pass

0.7196	25	25	100	Pass
0.7278	23	23	100	Pass
0.7360	22	22	100	Pass
0.7442	22	22	100	Pass
0.7525	21	21	100	Pass
0.7607	21	21	100	Pass
0.7689	18	18	100	Pass
0.7771	18	18	100	Pass
0.7853	15	15	100	Pass
0.7935	14	14	100	Pass
0.8017	14	14	100	Pass
0.8099	12	12	100	Pass
0.8181	11	11	100	Pass
0.8264	11	11	100	Pass
0.8346	11	11	100	Pass
0.8428	11	11	100	Pass
0.8510	11	11	100	Pass
0.8592	11	11	100	Pass
0.8674	11	11	100	Pass
0.8756	11	11	100	Pass
0.8838	11	11	100	Pass
0.8920	11	11	100	Pass
0.9002	11	11	100	Pass
0.9085	11	11	100	Pass
0.9167	11	11	100	Pass
0.9249	10	10	100	Pass
0.9331	9	9	100	Pass
0.9413	9	9	100	Pass
0.9495	8	8	100	Pass
0.9577	7	7	100	Pass
0.9659	7	7	100	Pass
0.9741	7	7	100	Pass
0.9824	7	7	100	Pass
0.9906	7	7	100	Pass
0.9988	7	7	100	Pass
1.0070	6	6	100	Pass
1.0152	6	6	100	Pass
1.0234	5	5	100	Pass
1.0316	5	5	100	Pass
1.0398	5	5	100	Pass
1.0480	5	5	100	Pass
1.0563	5	5	100	Pass
1.0645	5	5	100	Pass
1.0727	5	5	100	Pass
1.0809	4	4	100	Pass
1.0891	3	3	100	Pass
1.0973	3	3	100	Pass

Water Quality

Water Quality BMP Flow and Volume for POC #1

On-line facility volume: 0.1553 acre-feet

On-line facility target flow: 0.2195 cfs.

Adjusted for 15 min: 0.2195 cfs.

Off-line facility target flow: 0.1213 cfs.

Adjusted for 15 min: 0.1213 cfs.

LID Report

LID Technique	Used for Treatment ?	Total Volume Needs Treatment (ac-ft)	Volume Through Facility (ac-ft)	Infiltration Volume (ac-ft)	Cumulative Volume Infiltration Credit	Percent Volume Infiltrated	Water Quality	Percent Water Quality Treated	Comment
Total Volume Infiltrated		0.00	0.00	0.00		0.00	0.00	0%	No Treat. Credit
Compliance with LID Standard 8% of 2-yr to 50% of 2-yr									Duration Analysis Result = Passed

Model Default Modifications

Total of 0 changes have been made.

PERLND Changes

No PERLND changes have been made.

IMPLND Changes

No IMPLND changes have been made.

Appendix
Predeveloped Schematic



Mitigated Schematic

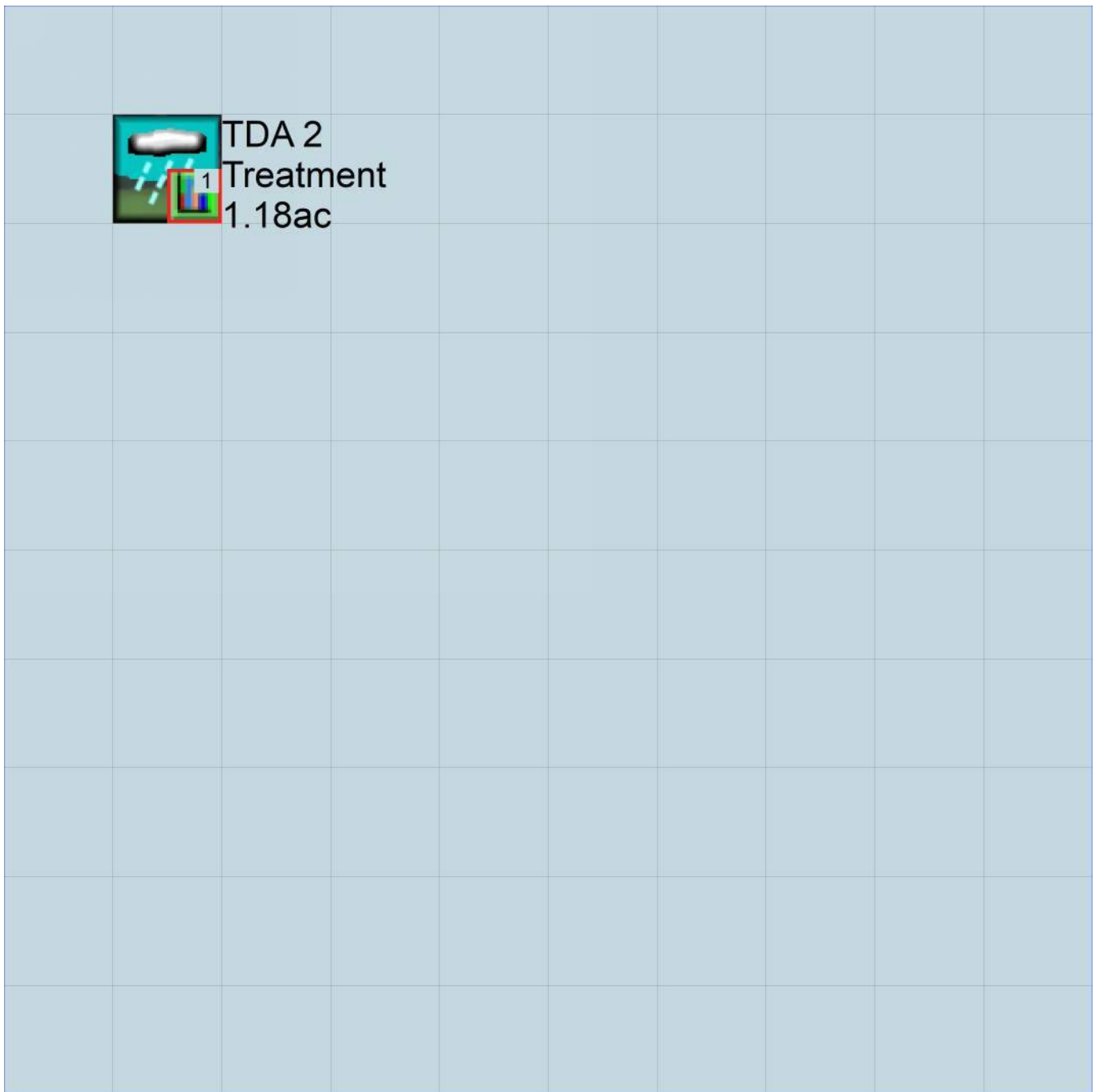

Predeveloped UCI File

RUN

GLOBAL

```
WVHM4 model simulation
START      1948 10 01      END      2008 09 30
RUN INTERP OUTPUT LEVEL    3      0
RESUME     0 RUN          1
UNIT SYSTEM                1
END GLOBAL
```

FILES

```
<File> <Un#> <-----File Name----->***
<-ID->                                     ***
WDM      26      13thPrelimTreatmentAnalysis.wdm
MESSU    25      Prel3thPrelimTreatmentAnalysis.MES
          27      Prel3thPrelimTreatmentAnalysis.L61
          28      Prel3thPrelimTreatmentAnalysis.L62
          30      POC13thPrelimTreatmentAnalysis1.dat
END FILES
```

OPN SEQUENCE

```
INGRP              INDELT 00:15
  PERLND           34
  IMPLND            1
  IMPLND            4
  IMPLND            8
  COPY             501
  DISPLY            1
END INGRP
```

END OPN SEQUENCE

DISPLY

```
DISPLY-INFO1
# - #<-----Title----->***TRAN PIVL DIG1 FIL1  PYR DIG2 FIL2 YRND
1      TDA 2 Treatment              MAX              1      2      30      9
END DISPLY-INFO1
```

END DISPLY

COPY

```
TIMESERIES
# - # NPT NMN ***
1      1      1
501    1      1
END TIMESERIES
```

END COPY

GENER

```
OPCODE
#      # OPCD ***
END OPCODE
PARAM
#      #          K ***
END PARAM
```

END GENER

PERLND

GEN-INFO

```
<PLS ><-----Name----->NBLKS  Unit-systems  Printer ***
# - #              User  t-series  Engl Metr ***
              in  out          ***
34      SG4, Lawn, Flat      1      1      1      1      27      0
END GEN-INFO
*** Section PWATER***
```

ACTIVITY

```
<PLS > ***** Active Sections *****
# - # ATMP SNOW PWAT  SED  PST  PWG  PQAL  MSTL  PEST  NITR  PHOS  TRAC ***
34      0      0      1      0      0      0      0      0      0      0      0
END ACTIVITY
```

PRINT-INFO

```
<PLS > ***** Print-flags ***** PIVL  PYR
# - # ATMP SNOW PWAT  SED  PST  PWG  PQAL  MSTL  PEST  NITR  PHOS  TRAC  *****
```

34 0 0 4 0 0 0 0 0 0 0 0 0 0 1 9
 END PRINT-INFO

PWAT-PARM1
 <PLS > PWATER variable monthly parameter value flags ***
 # - # CSNO RTOP UZFG VCS VUZ VNN VIFW VIRC VLE INFC HWT ***
 34 0 0 0 0 0 0 0 0 0 0 0 0
 END PWAT-PARM1

PWAT-PARM2
 <PLS > PWATER input info: Part 2 ***
 # - # ***FOREST LZSN INFILT LSUR SLSUR KVARY AGWRC
 34 0 6 0.02 400 0.05 0 0.96
 END PWAT-PARM2

PWAT-PARM3
 <PLS > PWATER input info: Part 3 ***
 # - # ***PETMAX PETMIN INFEXP INFILD DEEPFR BASETP AGWETP
 34 0 0 3 2 0 0 0
 END PWAT-PARM3

PWAT-PARM4
 <PLS > PWATER input info: Part 4 ***
 # - # CEPSC UZSN NSUR INTFW IRC LZETP ***
 34 0.1 0.2 0.25 2 0.4 0.25
 END PWAT-PARM4

PWAT-STATE1
 <PLS > *** Initial conditions at start of simulation
 ran from 1990 to end of 1992 (pat 1-11-95) RUN 21 ***
 # - # *** CEPS SURS UZS IFWS LZS AGWS GWVS
 34 0 0 0 0 2.5 1 0
 END PWAT-STATE1

END PERLND

IMPLND

GEN-INFO
 <PLS ><-----Name-----> Unit-systems Printer ***
 # - # User t-series Engl Metr ***
 in out ***
 1 ROADS/FLAT 1 1 1 27 0
 4 ROOF TOPS/FLAT 1 1 1 27 0
 8 SIDEWALKS/FLAT 1 1 1 27 0
 END GEN-INFO
 *** Section IWATER***

ACTIVITY
 <PLS > ***** Active Sections *****
 # - # ATMP SNOW IWAT SLD IWG IQAL ***
 1 0 0 1 0 0 0
 4 0 0 1 0 0 0
 8 0 0 1 0 0 0
 END ACTIVITY

PRINT-INFO
 <ILS > ***** Print-flags ***** PIVL PYR
 # - # ATMP SNOW IWAT SLD IWG IQAL *****
 1 0 0 4 0 0 0 1 9
 4 0 0 4 0 0 0 1 9
 8 0 0 4 0 0 0 1 9
 END PRINT-INFO

IWAT-PARM1
 <PLS > IWATER variable monthly parameter value flags ***
 # - # CSNO RTOP VRS VNN RTLI ***
 1 0 0 0 0 0
 4 0 0 0 0 0
 8 0 0 0 0 0
 END IWAT-PARM1

```

IWAT-PARM2
<PLS >          IWATER input info: Part 2          ***
# - # ***  LSUR      SLSUR      NSUR      RETSC
1         400      0.01      0.1      0.1
4         400      0.01      0.1      0.1
8         400      0.01      0.1      0.1
END IWAT-PARM2

IWAT-PARM3
<PLS >          IWATER input info: Part 3          ***
# - # ***PETMAX    PETMIN
1         0         0
4         0         0
8         0         0
END IWAT-PARM3

IWAT-STATE1
<PLS > *** Initial conditions at start of simulation
# - # ***  RETS      SURS
1         0         0
4         0         0
8         0         0
END IWAT-STATE1

END IMPLND

SCHEMATIC
<-Source->          <--Area-->          <-Target->  MBLK    ***
<Name> #           <-factor->          <Name> #    Tbl#    ***
TDA 2 Treatment***
PERLND 34          0.2916          COPY 501    12
PERLND 34          0.2916          COPY 501    13
IMPLND 1           0.6565          COPY 501    15
IMPLND 4           0.1781          COPY 501    15
IMPLND 8           0.0572          COPY 501    15

*****Routing*****
END SCHEMATIC

NETWORK
<-Volume-> <-Grp> <-Member-><--Mult-->Tran <-Target vols> <-Grp> <-Member-> ***
<Name> #      <Name> # #<-factor->strg <Name> # #      <Name> # #      ***
COPY 501 OUTPUT MEAN 1 1 48.4          DISPLAY 1      INPUT TIMSER 1

<-Volume-> <-Grp> <-Member-><--Mult-->Tran <-Target vols> <-Grp> <-Member-> ***
<Name> #      <Name> # #<-factor->strg <Name> # #      <Name> # #      ***
END NETWORK

RCHRES
GEN-INFO
RCHRES          Name          Nexits  Unit Systems  Printer          ***
# - #<-----><----> User T-series Engl Metr LKFG          ***
                                     in out
END GEN-INFO
*** Section RCHRES***

ACTIVITY
<PLS > ***** Active Sections *****
# - # HYFG ADFG CNFG HTFG SDFG GQFG OXFG NUFG PKFG PHFG ***
END ACTIVITY

PRINT-INFO
<PLS > ***** Print-flags ***** PIVL  PYR
# - # HYDR ADCA CONS HEAT SED  GQL  OXRX NUTR PLNK PHCB PIVL  PYR *****
END PRINT-INFO

HYDR-PARM1
RCHRES  Flags for each HYDR Section          ***

```

```

# - # VC A1 A2 A3 ODFVFG for each *** ODGTFG for each FUNCT for each
      FG FG FG FG possible exit *** possible exit possible exit
      * * * * * * * * * * * * * * * * * * * * * * * * * * * * * * * * * *
END HYDR-PARM1

HYDR-PARM2
# - # FTABNO LEN DELTH STCOR KS DB50 ***
<-----><-----><-----><-----><-----><-----><-----><-----> ***
END HYDR-PARM2
HYDR-INIT
RCHRES Initial conditions for each HYDR section ***
# - # *** VOL Initial value of COLIND Initial value of OUTDGT
      *** ac-ft for each possible exit for each possible exit
<-----><-----> <-----><-----><-----><-----> *** <-----><-----><-----><----->
END HYDR-INIT
END RCHRES

SPEC-ACTIONS
END SPEC-ACTIONS
FTABLES
END FTABLES

EXT SOURCES
<-Volume-> <Member> SsysSgap<--Mult-->Tran <-Target vols> <-Grp> <-Member-> ***
<Name> # <Name> # tem strg<-factor->strg <Name> # # <Name> # # ***
WDM 2 PREC ENGL 1.3 PERLND 1 999 EXTNL PREC
WDM 2 PREC ENGL 1.3 IMPLND 1 999 EXTNL PREC
WDM 1 EVAP ENGL 0.8 PERLND 1 999 EXTNL PETINP
WDM 1 EVAP ENGL 0.8 IMPLND 1 999 EXTNL PETINP
END EXT SOURCES

EXT TARGETS
<-Volume-> <-Grp> <-Member-><--Mult-->Tran <-Volume-> <Member> Tsys Tgap Amd ***
<Name> # <Name> # #<-factor->strg <Name> # <Name> tem strg strg***
COPY 501 OUTPUT MEAN 1 1 48.4 WDM 501 FLOW ENGL REPL
END EXT TARGETS

MASS-LINK
<Volume> <-Grp> <-Member-><--Mult--> <Target> <-Grp> <-Member->***
<Name> <Name> # #<-factor-> <Name> <Name> # #***
MASS-LINK 12
PERLND PWATER SURO 0.083333 COPY INPUT MEAN
END MASS-LINK 12

MASS-LINK 13
PERLND PWATER IFWO 0.083333 COPY INPUT MEAN
END MASS-LINK 13

MASS-LINK 15
IMPLND IWATER SURO 0.083333 COPY INPUT MEAN
END MASS-LINK 15

END MASS-LINK
END RUN

```

Mitigated UCI File

RUN

GLOBAL

```

WVHM4 model simulation
START      1948 10 01      END      2008 09 30
RUN INTERP OUTPUT LEVEL   3      0
RESUME     0 RUN          1
UNIT SYSTEM                1
END GLOBAL

```

FILES

```

<File> <Un#> <-----File Name----->***
<-ID->                                     ***
WDM      26      13thPrelimTreatmentAnalysis.wdm
MESSU    25      Mit13thPrelimTreatmentAnalysis.MES
          27      Mit13thPrelimTreatmentAnalysis.L61
          28      Mit13thPrelimTreatmentAnalysis.L62
          30      POC13thPrelimTreatmentAnalysis1.dat

```

END FILES

OPN SEQUENCE

```

INGRP              INDELT 00:15
  PERLND           34
  IMPLND            1
  IMPLND            4
  IMPLND            8
  COPY             501
  DISPLY           1

```

END INGRP

END OPN SEQUENCE

DISPLY

DISPLY-INFO1

```

# - #<-----Title----->***TRAN PIVL DIG1 FIL1  PYR DIG2 FIL2 YRND
1      TDA 2 Treatment              MAX              1      2      30      9

```

END DISPLY-INFO1

END DISPLY

COPY

TIMESERIES

```

# - # NPT NMN ***
1      1      1
501    1      1

```

END TIMESERIES

END COPY

GENER

OPCODE

```

#      # OPCODE ***

```

END OPCODE

PARAM

```

#      #          K ***

```

END PARAM

END GENER

PERLND

GEN-INFO

```

<PLS ><-----Name----->NBLKS  Unit-systems  Printer ***
# - #              User  t-series  Engl Metr ***
              in  out              ***

```

```

34      SG4, Lawn, Flat              1      1      1      1      27      0

```

END GEN-INFO

*** Section PWATER***

ACTIVITY

```

<PLS > ***** Active Sections *****
# - # ATMP SNOW PWAT  SED  PST  PWG  PQAL  MSTL  PEST  NITR  PHOS  TRAC ***
34      0      0      1      0      0      0      0      0      0      0      0

```

END ACTIVITY

PRINT-INFO

```

<PLS > ***** Print-flags ***** PIVL  PYR
# - # ATMP SNOW PWAT  SED  PST  PWG  PQAL  MSTL  PEST  NITR  PHOS  TRAC  *****

```

34 0 0 4 0 0 0 0 0 0 0 0 0 0 1 9
 END PRINT-INFO

PWAT-PARM1
 <PLS > PWATER variable monthly parameter value flags ***
 # - # CSNO RTOP UZFG VCS VUZ VNN VIFW VIRC VLE INFC HWT ***
 34 0 0 0 0 0 0 0 0 0 0 0 0
 END PWAT-PARM1

PWAT-PARM2
 <PLS > PWATER input info: Part 2 ***
 # - # ***FOREST LZSN INFILT LSUR SLSUR KVARY AGWRC
 34 0 6 0.02 400 0.05 0 0.96
 END PWAT-PARM2

PWAT-PARM3
 <PLS > PWATER input info: Part 3 ***
 # - # ***PETMAX PETMIN INFEXP INFILD DEEPFR BASETP AGWETP
 34 0 0 3 2 0 0 0
 END PWAT-PARM3

PWAT-PARM4
 <PLS > PWATER input info: Part 4 ***
 # - # CEPSC UZSN NSUR INTFW IRC LZETP ***
 34 0.1 0.2 0.25 2 0.4 0.25
 END PWAT-PARM4

PWAT-STATE1
 <PLS > *** Initial conditions at start of simulation
 ran from 1990 to end of 1992 (pat 1-11-95) RUN 21 ***
 # - # *** CEPS SURS UZS IFWS LZS AGWS GWVS
 34 0 0 0 0 2.5 1 0
 END PWAT-STATE1

END PERLND

IMPLND

GEN-INFO
 <PLS ><-----Name-----> Unit-systems Printer ***
 # - # User t-series Engl Metr ***
 in out ***
 1 ROADS/FLAT 1 1 1 27 0
 4 ROOF TOPS/FLAT 1 1 1 27 0
 8 SIDEWALKS/FLAT 1 1 1 27 0
 END GEN-INFO
 *** Section IWATER***

ACTIVITY
 <PLS > ***** Active Sections *****
 # - # ATMP SNOW IWAT SLD IWG IQAL ***
 1 0 0 1 0 0 0
 4 0 0 1 0 0 0
 8 0 0 1 0 0 0
 END ACTIVITY

PRINT-INFO
 <ILS > ***** Print-flags ***** PIVL PYR
 # - # ATMP SNOW IWAT SLD IWG IQAL *****
 1 0 0 4 0 0 0 1 9
 4 0 0 4 0 0 0 1 9
 8 0 0 4 0 0 0 1 9
 END PRINT-INFO

IWAT-PARM1
 <PLS > IWATER variable monthly parameter value flags ***
 # - # CSNO RTOP VRS VNN RTLI ***
 1 0 0 0 0 0
 4 0 0 0 0 0
 8 0 0 0 0 0
 END IWAT-PARM1

```

IWAT-PARM2
<PLS >          IWATER input info: Part 2          ***
# - # ***  LSUR      SLSUR      NSUR      RETSC
1          400      0.01      0.1      0.1
4          400      0.01      0.1      0.1
8          400      0.01      0.1      0.1
END IWAT-PARM2

IWAT-PARM3
<PLS >          IWATER input info: Part 3          ***
# - # ***PETMAX    PETMIN
1          0          0
4          0          0
8          0          0
END IWAT-PARM3

IWAT-STATE1
<PLS > *** Initial conditions at start of simulation
# - # ***  RETS      SURS
1          0          0
4          0          0
8          0          0
END IWAT-STATE1

END IMPLND

SCHEMATIC
<-Source->          <--Area-->          <-Target->  MBLK    ***
<Name> #          <-factor->          <Name> #  Tbl#    ***
TDA 2 Treatment***
PERLND 34          0.2916          COPY 501    12
PERLND 34          0.2916          COPY 501    13
IMPLND 1           0.6565          COPY 501    15
IMPLND 4           0.1781          COPY 501    15
IMPLND 8           0.0572          COPY 501    15

*****Routing*****
END SCHEMATIC

NETWORK
<-Volume-> <-Grp> <-Member-><--Mult-->Tran <-Target vols> <-Grp> <-Member-> ***
<Name> #          <Name> # #<-factor->strg <Name> # #          <Name> # # ***
COPY 501 OUTPUT MEAN 1 1 48.4          DISPLY 1          INPUT TIMSER 1

<-Volume-> <-Grp> <-Member-><--Mult-->Tran <-Target vols> <-Grp> <-Member-> ***
<Name> #          <Name> # #<-factor->strg <Name> # #          <Name> # # ***
END NETWORK

RCHRES
GEN-INFO
RCHRES          Name          Nexits  Unit Systems  Printer          ***
# - #<-----><----> User T-series  Engl Metr LKFG          ***
                                in out
END GEN-INFO
*** Section RCHRES***

ACTIVITY
<PLS > ***** Active Sections *****
# - # HYFG ADFG CNFG HTFG SDFG GQFG OXFG NUFQ PKFG PHFG ***
END ACTIVITY

PRINT-INFO
<PLS > ***** Print-flags ***** PIVL  PYR
# - # HYDR ADCA CONS HEAT SED  GQL  OXRX NUTR PLNK PHCB PIVL  PYR *****
END PRINT-INFO

HYDR-PARM1
RCHRES  Flags for each HYDR Section          ***

```

Predeveloped HSPF Message File

Mitigated HSPF Message File

Disclaimer

Legal Notice

This program and accompanying documentation are provided 'as-is' without warranty of any kind. The entire risk regarding the performance and results of this program is assumed by End User. Clear Creek Solutions Inc. and the governmental licensee or sublicensees disclaim all warranties, either expressed or implied, including but not limited to implied warranties of program and accompanying documentation. In no event shall Clear Creek Solutions Inc. be liable for any damages whatsoever (including without limitation to damages for loss of business profits, loss of business information, business interruption, and the like) arising out of the use of, or inability to use this program even if Clear Creek Solutions Inc. or their authorized representatives have been advised of the possibility of such damages. Software Copyright © by : Clear Creek Solutions, Inc. 2005-2023; All Rights Reserved.

Clear Creek Solutions, Inc.
6200 Capitol Blvd. Ste F
Olympia, WA. 98501
Toll Free 1(866)943-0304
Local (360)943-0304

www.clearcreeksolutions.com

SEPARATOR SHEET

Exhibit C
Isopluvial Maps for Design Storms in Clark County

2-Year, 24-Hour Isopluvials

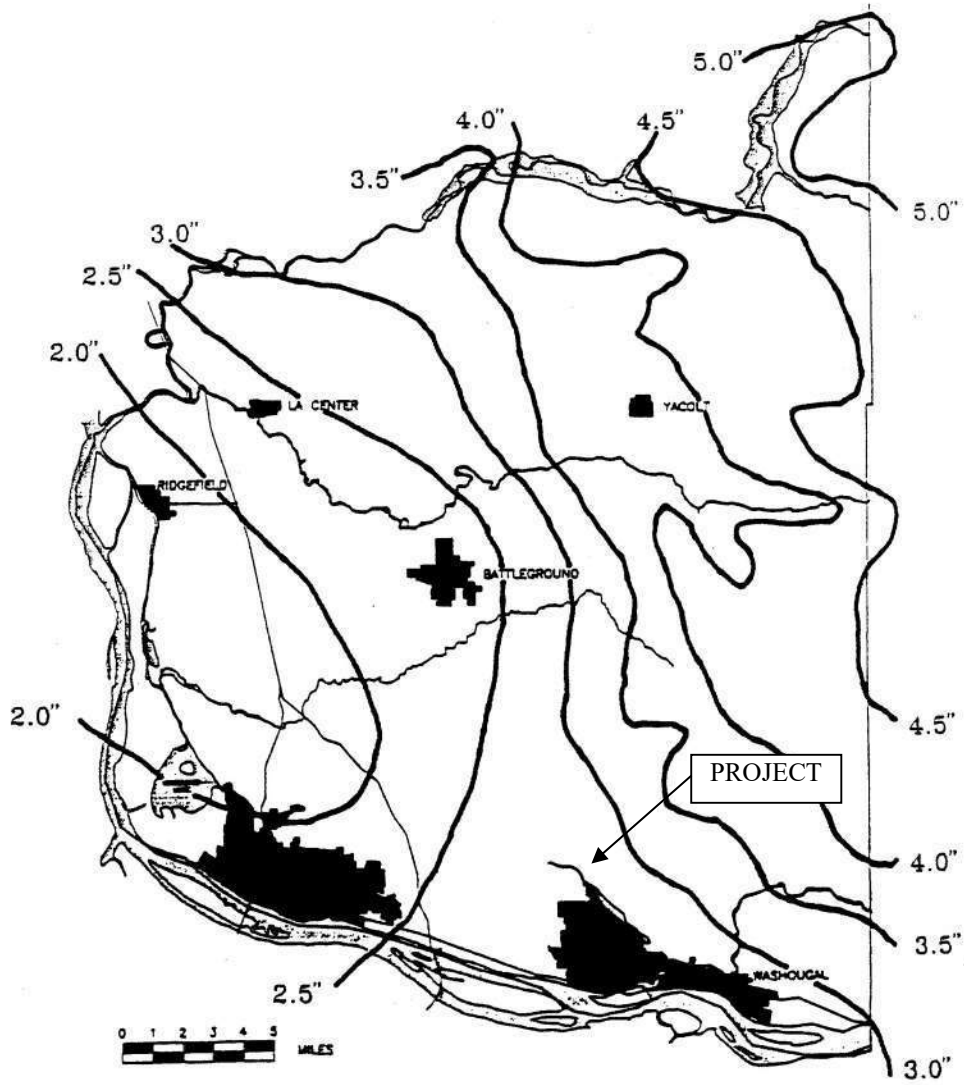

P=2.9"

Exhibit C
Isopluvial Maps for Design Storms in Clark County

10-Year, 24-Hour Isopluviats

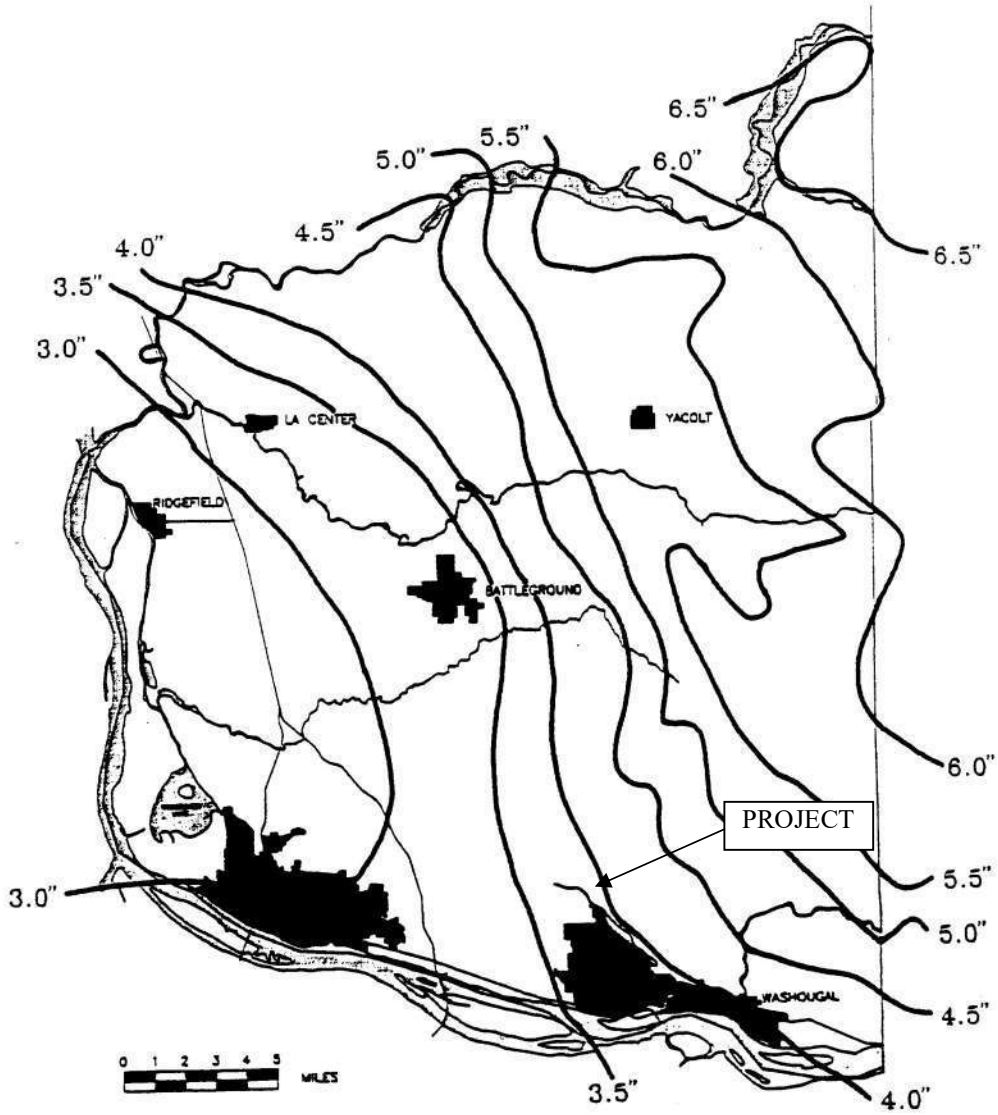

P=4.0"

Exhibit C
Isopluvial Maps for Design Storms in Clark County

100-Year, 24-Hour Isopluvials

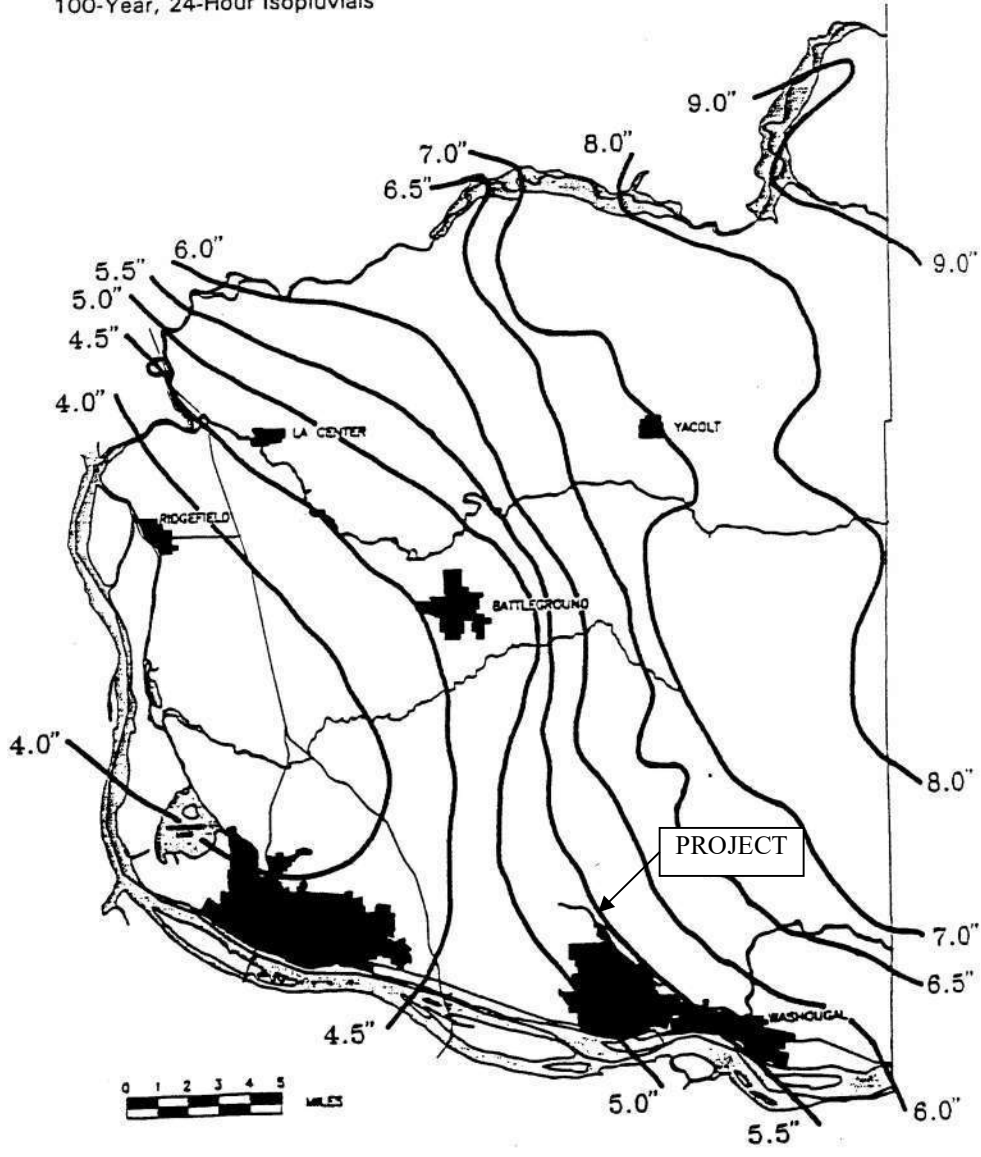

P=5.5"

SEPARATOR SHEET



April 2017

GENERAL USE LEVEL DESIGNATION FOR BASIC (TSS) TREATMENT

For

CONTECH Engineered Solutions Stormwater Management **StormFilter**[®] With ZPG Media at 1 gpm/sq ft media surface area

Ecology's Decision:

Based on the CONTECH Engineered Solutions' (CONTECH) application submissions, Ecology hereby issues a General Use Level Designation (GULD) for the Stormwater Management StormFilter[®] (StormFilter):

1. As a basic stormwater treatment practice for total suspended solids (TSS) removal,
 - Using ZPG[™] media (zeolite/perlite/granular activated carbon), with the size distribution described below,
 - Sized at a hydraulic loading rate of 1 gpm/ft² of media surface area, per Table 1, and
 - Internal bypassing needs to be consistent with the design guidelines in CONTECH's current product design manual.

Table 1. StormFilter Design Flow Rates per Cartridge

Effective Cartridge Height (inches)	12	18	27
Cartridge Flow Rate (gpm/cartridge)	5	7.5	11.3

2. Ecology approves StormFilter systems containing ZPG[™] media for treatment at the hydraulic loading rates shown in Table 1, and sized based on the water quality design flow rate for an off-line system when using an external bypass vault or a treatment vault with an internal bypass. Contech designs their StormFilter systems to maintain treatment of the water quality design flow while routing excess flows around the treatment chamber during periods of peak bypass. The water quality design flow rates are calculated using the following procedures:

- **Western Washington:** For treatment installed upstream of detention or retention, the water quality design flow rate is the peak 15-minute flow rate as calculated using the latest version of the Western Washington Hydrology Model or other Ecology-approved continuous runoff model.

- **Eastern Washington:** For treatment installed upstream of detention or retention, the water quality design flow rate is the peak 15-minute flow rate as calculated using one of the three methods described in Chapter 2.2.5 of the Stormwater Management Manual for Eastern Washington (SWMMEW) or local manual.
- **Entire State:** For treatment installed downstream of detention, the water quality design flow rate is the full 2-year release rate of the detention facility.

3. This designation has no expiration date, but Ecology may amend or revoke it.

Ecology's Conditions of Use:

The StormFilter with ZPG media shall comply with the following conditions:

- 1. Design, install, operate, and maintain the StormFilter with ZPG media in accordance with applicable Contech Engineered Solutions manuals, documents, and the Ecology Decision.**
- 2. Install StormFilter systems to bypass flows exceeding the water quality treatment rate. Additionally, high flows will not re-suspend captured sediments. Design StormFilter systems in accordance with the performance goals in Ecology's most recent Stormwater Manual and CONTECH's *Product Design Manual Version 4.1 (April 2006)*, or most current version, unless otherwise specified.**
- 3. Owners must follow the design, pretreatment, land use application, and maintenance criteria in CONTECH's Design Manual.**
- 4. Pretreatment of TSS and oil and grease may be necessary, and designers shall provide pre-treatment in accordance with the most current versions of the CONTECH's *Product Design Manual (April 2006)* or the applicable Ecology Stormwater Manual. Design pre-treatment using the performance criteria and pretreatment practices provided on Ecology's "Evaluation of Emerging Stormwater Treatment Technologies" website.**
- 5. Maintenance: The required maintenance interval for stormwater treatment devices is often dependent upon the degree of pollutant loading from a particular drainage basin. Therefore, Ecology does not endorse or recommend a "one size fits all" maintenance cycle for a particular model/size of manufactured filter treatment device.**
 - **Typically, CONTECH designs StormFilter systems for a target filter media replacement interval of 12 months. Maintenance includes removing accumulated sediment from the vault, and replacing spent cartridges with recharged cartridges.**

- **Indications of the need for maintenance include effluent flow decreasing to below the design flow rate, as indicated by the scumline above the shoulder of the cartridge.**
 - **Owners/operators must inspect StormFilter with ZPG media for a minimum of twelve months from the start of post-construction operation to determine site-specific maintenance schedules and requirements. You must conduct inspections monthly during the wet season, and every other month during the dry season. (According to the SWMMWW, the wet season in western Washington is October 1 to April 30. According to SWMMEW, the wet season in eastern Washington is October 1 to June 30). After the first year of operation, owners/operators must conduct inspections based on the findings during the first year of inspections.**
 - **Conduct inspections by qualified personnel, follow manufacturer’s guidelines, and use methods capable of determining either a decrease in treated effluent flowrate and/or a decrease in pollutant removal ability.**
 - **When inspections are performed, the following findings typically serve as maintenance triggers:**
 - **Accumulated vault sediment depths exceed an average of 2 inches, or**
 - **Accumulated sediment depths on the tops of the cartridges exceed an average of 0.5 inches, or**
 - **Standing water remains in the vault between rain events, or**
 - **Bypass occurs during storms smaller than the design storm.**
 - **Note: If excessive floatables (trash and debris) are present, perform a minor maintenance consisting of gross solids removal, not cartridge replacement.**
- 6. CONTECH shall maintain readily available reports listed under “Application Documents” (above) as public, as well as the documentation submitted with its previous conditional use designation application. CONTECH shall provide links to this information from its corporate website, and make this information available upon request, at no cost and in a timely manner.**
- 7. ZPG™ media used shall conform with the following specifications:**
- **Each cartridge contains a total of approximately 2.6 cubic feet of media. The ZPG™ cartridge consists of an outer layer of perlite that is approximately 1.3 cubic feet in volume and an inner layer, consisting of a mixture of 90% zeolite and 10% granular activated carbon, which is approximately 1.3 cubic feet in volume.**
 - **Perlite Media: Perlite media shall be made of natural siliceous volcanic rock free of any debris or foreign matter. The expanded perlite shall**

have a bulk density ranging from 6.5 to 8.5 lbs per cubic foot and particle sizes ranging from 0.09” (#8 mesh) to 0.38” (3/8” mesh).

- **Zeolite Media:** Zeolite media shall be made of naturally occurring clinoptilolite. The zeolite media shall have a bulk density ranging from 44 to 50 lbs per cubic foot and particle sizes ranging from 0.13” (#6 mesh) to 0.19” (#4 mesh). Additionally, the cation exchange capacity (CEC) of zeolite shall range from approximately 1.0 to 2.2 meq/g.
- **Granular Activated Carbon:** Granular activated carbon (GAC) shall be made of lignite coal that has been steam-activated. The GAC media shall have a bulk density ranging from 28 to 31 lbs per cubic foot and particle sizes ranging from a 0.09” (#8 mesh) to 0.19” (#4 mesh).

Approved Alternate Configurations

Peak Diversion StormFilter

1. The Peak Diversion StormFilter allows for off-line bypass within the StormFilter structure. Design capture flows and peak flows enter the inlet bay which contains an internal weir. The internal weir allows design flows to enter the cartridge bay through a transfer hole located at the bottom of the inlet bay while the unit routes higher flows around the cartridge bay.
2. To select the size of the Peak Diversion StormFilter unit, the designer must determine the number of cartridges required and size of the standard StormFilter using the site-specific water quality design flow and the **StormFilter Design Flow Rates per Cartridge** as described above.
3. New owners may not install the Peak Diversion StormFilter at an elevation or in a location where backwatering may occur.

Applicant: Contech Engineered Solutions

Applicant’s Address: 11835 NE Glenn Widing Dr.
Portland, OR 97220

Application Documents:

The applicant’s master report, titled, “The Stormwater Management StormFilter Basic Treatment Application for General Use Level Designation in Washington”, Stormwater Management, Inc., November 1, 2004, includes the following reports:

- (Public) *Evaluation of the Stormwater Management StormFilter Treatment System: Data Validation Report and Summary of the Technical Evaluation Engineering Report (TEER)* by Stormwater Management Inc., October 29, 2004
Ecology’s technology assessment protocol requires the applicant to hire an independent consultant to complete the following work:

1. Complete the data validation report.
 2. Prepare a TEER summary, including a testing summary and conclusions compared with the supplier's performance claims.
 3. Provide a recommendation of the appropriate technology use level.
 4. Work with Ecology to post recommend relevant information on Ecology's website.
 5. Provide additional testing recommendations, if needed."
 6. This report, authored by Dr. Gary Minton, Ph. D., P.E., Resource Planning Associates, satisfies the Ecology requirement.
- (Public) "Performance of the Stormwater Management StormFilter Relative to the Washington State Department of Ecology Performance Goals for Basic Treatment," is a summary of StormFilter performance that strictly adheres to the criteria listed in the Guidance for Evaluating Emerging Stormwater Treatment Technologies, Technology Assessment Protocol – Ecology (TAPE).
 - "Heritage Marketplace Field Evaluation: Stormwater Management StormFilter with ZPG™ Media," is a report showing all of the information collected at Site A as stated in the SMI Quality Assurance Project Plan (QAPP). This document contains detailed information regarding each storm event collected at this site, and it provided a detailed overview of the data and project.
 - "Lake Stevens Field Evaluation: Stormwater Management StormFilter with ZPG™ Media," is a report that corresponds to Site E as stated in the SMI QAPP. This document contains detailed information regarding each storm collected at this site, and includes a detailed overview of the data and project.
 - (Public) "Evaluation of the Stormwater Management StormFilter for the removal of SIL-CO-SIL 106, a standardized silica product: ZPG™ at 7.5 GPM" is a report that describes laboratory testing at full design flow.
 - "Factors Other Than Treatment Performance."
 - "State of Washington Installations."
 - "Peak Diversion StormFilter" is a technical document demonstrating the Peak Diversion StormFilter system complies with the Stormwater Management Manual for Western Washington Volume V Section 4.5.1.

Above-listed documents noted as "public" are available by contacting CONTECH.

Applicant's Use Level Request:

That Ecology grant a General Use Level Designation for Basic Treatment for the StormFilter using ZPG™ media (zeolite/perlite/granular activated carbon) at a hydraulic loading rate of 1 gpm/ft² of media surface area in accordance with Ecology's 2011 *Technical Guidance Manual for Evaluating Emerging Stormwater Treatment Technologies Technology Assessment Protocol – Ecology (TAPE)*.

Applicant's Performance Claim:

The combined data from the two field sites reported in the TER (Heritage Marketplace and Lake Stevens) indicate that the performance of a StormFilter system configured for inline bypass with ZPG™ media and a hydraulic loading rate of 1 gpm/ft² of media surface area meets Ecology performance goals for Basic Treatment.

Ecology's Recommendations:

Based on the weight of the evidence and using its best professional judgment, Ecology finds that:

- StormFilter, using ZPG™ media and operating at a hydraulic loading rate of no more than 1 gpm/ft² of media surface area, is expected to provide effective stormwater treatment achieving Ecology's Basic Treatment (TSS removal) performance goals. Contech demonstrated this is through field and laboratory testing performed in accordance with the approved protocol. StormFilter is deemed satisfactory with respect to factors other than treatment performance (e.g., maintenance; see the protocol's Appendix B for complete list).

Findings of Fact:

- Influent TSS concentrations and particle size distributions were generally within the range of what Ecology considers "typical" for western Washington (silt-to-silt loam).
- Contech sampled thirty-two (32) storm events at two sites for storms from April 2003 to March 2004, of which Contech deemed twenty-two (22) as "qualified" and were therefore included in the data analysis set.
- Statistical analysis of these 22 storm events verifies the data set's adequacy.
- Analyzing all 22 qualifying events, the average influent and effluent concentrations and aggregate pollutant load reduction are 114 mg/L, 25 mg/L, and 82%, respectively.
- Analyzing all 22 qualifying events based on the *estimated average* flow rate during the event (versus the *measured peak* flow rate), and more heavily weighting those events near the design rate (versus events either far above or well below the design rate) does not significantly affect the reported results.
- For the 7 qualifying events with influent TSS concentrations greater than 100 mg/L, the average influent and effluent concentrations and aggregate pollutant load reduction are 241 mg/L, 34 mg/L, and 89%, respectively. If we exclude the 2 of 7 events that exceed the maximum 300 mg/L specified in Ecology's guidelines, the average influent and effluent concentrations and aggregate pollutant load reduction are 158 mg/L, 35 mg/L, and 78%, respectively.
- For the 15 qualifying events with influent TSS concentrations less than 100 mg/L, the average influent and effluent concentrations and aggregate pollutant load reduction are 55 mg/L, 20 mg/L, and 61%, respectively. If the 6 of 15 events that fall below the minimum 33 mg/L TSS specified in Ecology's guidelines are excluded, the average

influent and effluent concentrations and aggregate pollutant load reduction are 78 mg/L, 26 mg/L, and 67%, respectively.

- For the 8 qualifying events with peak discharge exceeding design flow (ranging from 120 to 257% of the design rate), results ranged from 52% to 96% TSS removal, with an average of 72%.
- Due to the characteristics of the hydrographs, the field results generally reflect flows below (ranging between 20 and 60 percent of) the tested facilities' design rate. During these sub-design flow rate periods, some of the cartridges operate at or near their *individual* full design flow rate (generally between 4 and 7.5 GPM for an 18" cartridge effective height) because their float valves have opened. Float valves remain closed on the remaining cartridges, which operate at their base "trickle" rate of 1 to 1.5 GPM.
- Laboratory testing using U.S. Silica's Sil-Co-Sil 106 fine silica product showed an average 87% TSS removal for testing at 7.5 GPM per cartridge (100% design flow rate).
- Other relevant testing at I-5 Lake Union, Greenville Yards (New Jersey), and Ski Run Marina (Lake Tahoe) facilities shows consistent TSS removals in the 75 to 85% range. *Note that the evaluators operated the I-5 Lake Union at 50%, 100%, and 125% of design flow.*
- SMI's application included a satisfactory "Factors other than treatment performance" discussion.

Note: Ecology's 80% TSS removal goal applies to 100 mg/l and greater influent TSS. Below 100 mg/L influent TSS, the goal is 20 mg/L effluent TSS.

Technology Description:

The Stormwater Management StormFilter[®] (StormFilter), a flow-through stormwater filtration system, improves the quality of stormwater runoff from the urban environment by removing pollutants. The StormFilter can treat runoff from a wide variety of sites including, but not limited to: retail and commercial development, residential streets, urban roadways, freeways, and industrial sites such as shipyards, foundries, etc.

Operation:

The StormFilter is typically comprised of a vault that houses rechargeable, media-filled, filter cartridges. Various media may be used, but this designation covers only the zeolite-perlite-granulated activated carbon (ZPG[™]) medium. Stormwater from storm drains percolates through these media-filled cartridges, which trap particulates and may remove pollutants such as dissolved metals, nutrients, and hydrocarbons. During the filtering process, the StormFilter system also removes surface scum and floating oil and grease. Once filtered through the media, the treated stormwater is directed to a collection pipe or discharged to an open channel drainage way.

This document includes a bypass schematic for flow rates exceeding the water quality design flow rate on page 8.

StormFilter Configurations:

Contech offers the StormFilter in multiple configurations: precast, high flow, catch basin, curb inlet, linear, volume, corrugated metal pipe, drywell, and CON/Span form. Most configurations use pre-manufactured units to ease the design and installation process. Systems may be either uncovered or covered underground units.

The typical precast StormFilter unit is composed of three sections: the energy dissipater, the filtration bay, and the outlet sump. As Stormwater enters the inlet of the StormFilter vault through the inlet pipe, piping directs stormwater through the energy dissipater into the filtration bay where treatment will take place. Once in the filtration bay, the stormwater ponds and percolates horizontally through the media contained in the StormFilter cartridges. After passing through the media, the treated water in each cartridge collects in the cartridge's center tube from where piping directs it into the outlet sump by a High Flow Conduit under-drain manifold. The treated water in the outlet sump discharges through the single outlet pipe to a collection pipe or to an open channel drainage way. In some applications where you anticipate heavy grit loads, pretreatment by settling may be necessary.

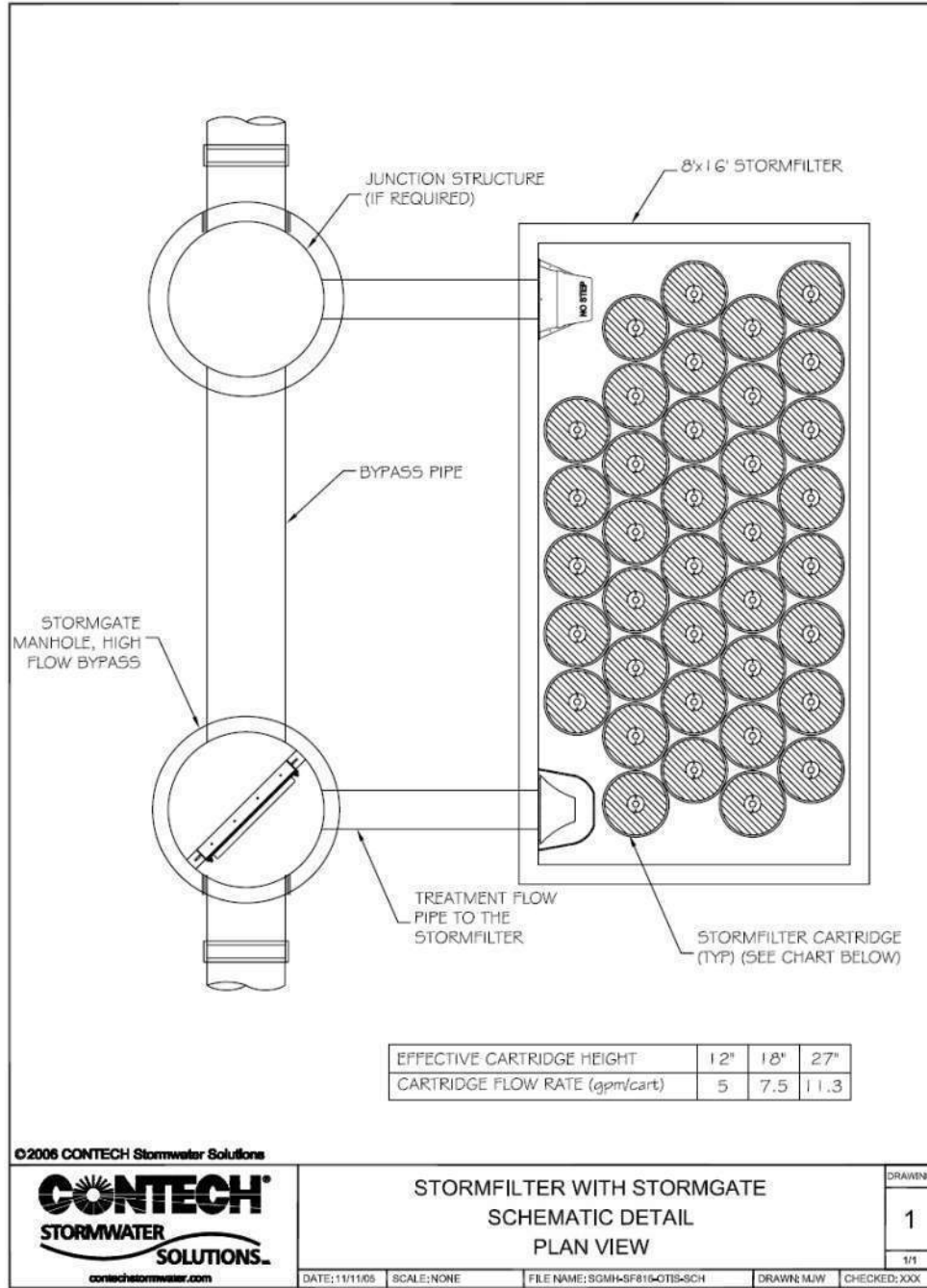

Figure 1. Stormwater Management StormFilter Configuration with Bypass

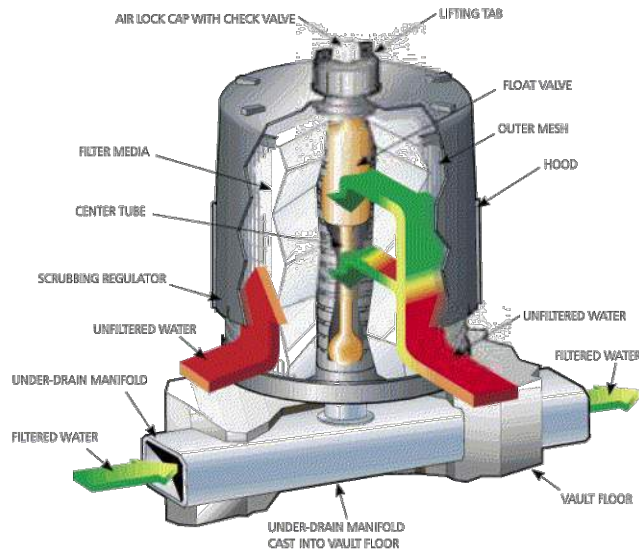

Figure 2. The StormFilter Cartridge

Cartridge Operation:

As the water level in the filtration bay begins to rise, stormwater enters the StormFilter cartridge. Stormwater in the cartridge percolates horizontally through the filter media and passes into the cartridge's center tube, where the float in the cartridge is in a closed (downward) position. As the water level in the filtration bay continues to rise, more water passes through the filter media and into the cartridge's center tube. Water displaces the air in the cartridge and it purges from beneath the filter hood through the one-way check valve located in the cap. Once water fills the center tube there is enough buoyant force on the float to open the float valve and allow the treated water to flow into the under-drain manifold. As the treated water drains, it tries to pull in air behind it. This causes the check valve to close, initiating a siphon that draws polluted water throughout the full surface area and volume of the filter. Thus, water filters through the entire filter cartridge throughout the duration of the storm, regardless of the water surface elevation in the filtration bay. This continues until the water surface elevation drops to the elevation of the scrubbing regulators. At this point, the siphon begins to break and air quickly flows beneath the hood through the scrubbing regulators, causing energetic bubbling between the inner surface of the hood and the outer surface of the filter. This bubbling agitates and cleans the surface of the filter, releasing accumulated sediments on the surface, flushing them from beneath the hood, and allowing them to settle to the vault floor.

Adjustable cartridge flow rate:

Inherent to the design of the StormFilter is the ability to control the individual cartridge flow rate with an orifice-control disc placed at the base of the cartridge. Depending on the treatment requirements and on the pollutant characteristics of the influent stream as

specified in the CONTECH *Product Design Manual*, operators may adjust the flow rate through the filter cartridges. By decreasing the flow rate through the filter cartridges, the influent contact time with the media is increased and the water velocity through the system is decreased, thus increasing both the level of treatment and the solids removal efficiencies of the filters, respectively (de Ridder, 2002).

Recommended research and development:

Ecology encourages CONTECH to pursue continuous improvements to the StormFilter. To that end, CONTECH recommends the following actions:

- Determine, through laboratory testing, the relationship between accumulated solids and flow rate through the cartridge containing the ZPG™ media. **Completed 11/05.**
- Determine the system's capabilities to meet Ecology's enhanced, phosphorus, and oil treatment goals.
- Develop easy-to-implement methods of determining that a StormFilter facility requires maintenance (cleaning and filter replacement).

Contact Information:

Applicant Contact: Jeremiah Lehman
Contech Engineered Solutions
11835 NE Glenn Widing Drive
Portland, OR, 97220
503-258-3136
jlehman@conteches.com

Applicant Web link <http://www.conteches.com/>

Ecology web link: <http://www.ecy.wa.gov/programs/wq/stormwater/newtech/index.html>

Ecology Contact: Douglas C. Howie, P.E.
 Department of Ecology
 Water Quality Program
 (360) 407-6444
douglas.howie@ecy.wa.gov

Revision History

Date	Revision
Jan 2005	Original Use Level Designation
Dec 2007	Revision
May 2012	Maintenance requirements updated
November 2012	Design Storm and Maintenance requirements updated
January 2013	Updated format to match Ecology standard format
September 2014	Added Peak Diversion StormFilter Alternate Configuration
November 2016	Revised Contech contact information
April 2017	Revised sizing language to note sizing based on Off-line calculations

SEPARATOR SHEET

APPENDIX C

Geotechnical Report

GEOTECHNICAL ENGINEERING STUDY

**13th Street Gas Station
NE 13th Street & NW Friberg-Strunk Street
Camas, Clark County, Washington
Tax Lot No. (176148000)**

**Prepared for:
Taz Khan
701 Columbia Street #109
Vancouver, WA 98660**

Prepared By:

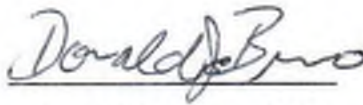

**Donald J. Bruno, CEG
Engineering Geologist**



DONALD J. BRUNO

Project No. G26-0723

{August 2023}

**Earth Engineering Inc.
PO Box 1512, Ridgefield, Washington 98642
(360) 600-6518**

Earth Engineering, Inc.

Geotechnical & Environmental Consultants

Taz Khan
701 Columbia Street #109
Vancouver, Washington 98660

August 31st 2023
G26-0723

Subject: Geotechnical Engineering Study
13th Street Gas Station, C-Store & Car Wash
NE 13th Street & NW Friberg-Strunk Street
Camas, Clark County, Washington
(Tax Lot No. 176148000)

Hello Taz,

We are pleased to submit our engineering report for the subject property located in Camas, Washington. This report presents the results of our field exploration, selective laboratory tests, field testing and engineering analyses.

Based on the results of this study, it is our opinion that construction of the proposed commercial structures is feasible from a geotechnical standpoint, provided recommendations presented in this report are included in the project design.

We appreciate the opportunity to have been of service to you and look forward to working with you in the future. Should you have any questions about the content of this report, or if we can be of further assistance, please call.

Respectfully Submitted,
Earth Engineering Inc.,

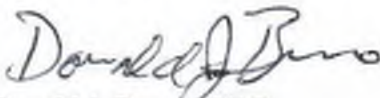

Donald J. Bruno, CEG
Engineering Geologist

TABLE OF CONTENTS
{G26-0723}

<u>INTRODUCTION</u>	1
General	1
Project Description	1
<u>SITE CONDITIONS</u>	1-2
Surface	1
Subsurface.....	2
Groundwater	2
General Regional Geology	2
<u>LABORATORY TESTING</u>	2-3
<u>SEISMIC HAZARD EVALUATION</u>	3
<u>DISCUSSION AND RECOMMENDATIONS</u>	4-5
General	4
Site Preparation & Grading.....	4-5
Foundations	5-6
Slab on Grade.....	6
Temporary Excavations.....	6
Infiltration Testing	7
Site Drainage	7
Utility Support & Back Fill	7-8
Pavements	8
Additional Services	9
<u>LIMITATIONS</u>	9
 <u>GRAPHICS</u>	
Figure 1	Vicinity Map
Figure 2	Site Plan (Test Pit & Infiltration Locations)
Figure 3	Typical Footing Drain Detail
Figure 4	Typical Utility Trench Back Fill Detail
 <u>APPENDICES</u>	
Appendix A	Field Exploration
Plate A1	Unified Soil Classification- Legend
Plates A2-A3	Log of Exploratory Test Pits

INTRODUCTION

General

This report presents the results of the geotechnical engineering study completed by Earth Engineering, Inc. for the proposed gas station, convenience store and drive thru car wash located in Camas, Washington. The general location of the site is shown on the *Vicinity Map, Figure 1*. At the time our study was performed, the site and our exploratory locations are approximately as shown on the *Site Plan, Figure 2*.

The purpose of this study was to explore subsurface conditions at the site and based on the conditions encountered provide geotechnical recommendations for the proposed construction. In addition this report includes infiltration testing for stormwater design and a seismic hazard evaluation.

Project Description

Based on the information that was provided to us by the project civil engineer (PLS), it is our understanding the site will be developed with a one story convenience store building that will provide four thousand one-hundred (4100) square feet of floor space, a one thousand one-hundred and eighty nine (1189) square foot drive thru car wash, a fuel pumping island, trash enclosure and an asphalt paved access driveway with vehicle parking spaces. Construction will also include the installation of a stormwater system and subsurface utilities.

Due to the relatively flat topography, it is anticipated that earthwork cuts and fills will be less than two feet to achieve the desired design grade. The convenience store and car wash structures will be constructed with a metal or wood frame and slab on grade floors.

Structural design loads were not available at the time this report was written. However, based on our experience with similar projects, we anticipate that wall and column loads will be approximately seven hundred and fifty (750) to one thousand five hundred (1500) pounds per lineal foot (maximum dead plus live loads). Slab on grade loads will most likely range from one hundred (100) to one hundred and fifty (150) pounds per square foot (psf).

If any of the above information is incorrect or changes, we should be consulted to review the recommendations contained in this report. In any case, it is recommended that Earth Engineering, Inc. perform a general review of the final design for the proposed construction.

SITE CONDITIONS

Surface

The rectangular shaped property encompasses approximately one acre. An existing single family residence was located at the central west area of the property. The adjacent properties to the south and west are moderately to heavily vegetated with single family homes on acreage. NE 13th Street borders the north side and NW Friberg-Strunk Street.

The property is relatively level and slopes gently downward from the north to the south and southeast with an overall elevation change of approximately five feet and a gradient that is less than two percent (2%). The property has been landscaped with a manicured lawn as well as a variety of trees and flowering bushes.

Subsurface & Soil Classification

For this study, the site was explored by excavating two test pits at the approximate locations shown on the *Site Plan, Figure 2*. Infiltration testing was performed in both test pits. All soil was classified following the Unified Soil Classification System (USCS). A USCS Legend is included as Plate A1. A description of the field exploration methods is included in Appendix A.

In general, in our test pits we encountered very stiff to hard soil consisting of Silt (ML) and lean Clay (CL) to the maximum exploration depth of ten and one half (10.5) feet below the existing ground surface. Please refer to the test pit logs, Plates A-2 thru A-3, for a more detailed description of the conditions encountered.

Groundwater

During the time of our field exploration (August 2023) groundwater was not encountered in any of our test pits. It is important to note that groundwater conditions are not static; fluctuations may be expected in the level and seepage flow depending on the season, amount of, surface water runoff, and other factors. Generally, groundwater levels are higher and the seepage rate is greater in the wetter winter months (typically October through May).

General Regional Geology

General information about geologic conditions and soil in the vicinity of the site was obtained by reviewing the Geologic Map of Washington-Southwest Quadrant, Washington Division of Geology and Earth Resources, (Geologic Map GM-34, 1987). This map provides general information about geologic units in the Camas, Clark County, Washington area.

Our review of existing geological information indicates that soils in the vicinity of the subject site were formed from alluvial deposits during the Quaternary Period. Outburst flood deposits from glacial Lake Missoula deposited these sedimentary soils. The native material encountered in our test pits consists predominantly of Silt.

LABORATORY TESTING

Laboratory tests were conducted on representative soil samples to verify or modify the field soil classification of the units encountered, and to evaluate the general physical properties as well as the engineering characteristics of the soils encountered. The following provides information about the testing procedures performed on representative soil samples and the general condition of subsurface soil conditions encountered:

- *Moisture Content (ASTM-D2216-92)* tests were performed on representative samples. The native Silt has a moisture content that ranges from thirteen to forty three percent (13-43 %). The native lean clay has a moisture content of thirty eight percent (38%)
- *In-Situ Soil Density (ASTM-D4564-93)* utilizing the sleeve method was performed on representative samples to determine the wet and dry density of native soil. The in-situ density provides a relative indication of soil support characteristics. The average wet density of the native silt is one hundred and ten (110) pounds per cubic foot (pcf). The average dry density of this soil is ninety six (96) pcf.

Laboratory testing confirms that subsurface soil consists predominantly of Silt and lean Clay. These types of soil are sensitive to changes in moisture content. Moisture sensitive soils are discussed in more detail in the *Site Preparation and Grading* section of this report.

The results of laboratory tests performed on specific samples are provided at the appropriate sample depth on the individual test pit logs. However, it is important to note that some variation of subsurface conditions may exist. Our geotechnical recommendations are based on our interpretation of these test results.

SEISMIC HAZARD EVALUATION

The following provides a seismic hazard evaluation for the proposed commercial building and fuel island. Our evaluation is based on subsurface conditions encountered at the site during the time of our geotechnical study and a review of applicable geologic maps (Washington State Department of Natural Resources, Geologic Map of Washington-Southwest Quadrant, 1987) and the International Building Code (IBC-2018) guidelines.

In general, supportive soil at the subject site consists of very stiff to hard Silt. The geologic map indicates that no known active faults are located within one-mile of the subject site. Soils encountered at the site are classified as a type "D" soil in accordance with "Seismic Design Categories" (IBC 2018, Section 1803.5.12).

Liquefaction:

Structures are subject to damage from earthquakes due to direct and indirect action. Shaking represents direct action. Indirect action is represented by foundation failures and is typified by liquefaction. Liquefaction occurs when soil loses all shear strength for short periods of time during an earthquake. Ground shaking of sufficient duration results in the loss of grain to grain contact as well as a rapid increase in pore water pressure. This causes the soil to assume physical properties of a fluid.

To have potential for liquefaction a soil must be loose, cohesion-less (generally sands and silts), below the groundwater table, and must be subjected to sufficient magnitude and duration of ground shaking. The effects of liquefaction may be large total settlement and/or large differential settlement for structures with foundations in or above the liquefied soil. Based on the very stiff to hard soil conditions encountered and the absence of a near surface groundwater table, it is not likely that soil liquefaction would occur at the subject site during a seismic event.

DISCUSSION AND RECOMMENDATIONS

General

Based on the results of our study, it is our opinion the commercial project can be developed as planned provided the geotechnical recommendations contained in this report are incorporated into the final design. The proposed buildings (convenience store & car wash) as well as the fuel island canopy can be supported on conventional shallow spread footings bearing either entirely on competent native soil or compacted structural fill. Supporting the proposed buildings on homogeneous material will significantly decrease the potential for differential settlement across the foundation area.

This report has been prepared for specific application to this project only and in a manner consistent with that level of care and skill ordinarily exercised by other members of the profession currently practicing under similar conditions in this area for the exclusive use of Taz Khan and their representatives. This report, in its entirety, should be included in the project documents for information to the contractor. No warranty, expressed or implied, is made.

Site Preparation and Grading

The site shall be stripped and cleared of all vegetation, organic matter and any other deleterious material. Stripped material should not be mixed with any soils to be used as fill. Stripped soil could potentially be used for topsoil at landscape areas after removing vegetation and screening out organic matter.

Building and Driveway Areas:

After clearing and grading, the exposed sub-grade at building and pavement areas should be compacted to a dense non-yielding condition with suitable compaction equipment. This phase of earthwork compaction shall be performed prior to the placement of structural fill, at the bottom of all foundation excavations, interior and exterior concrete slabs, as well as the driveway-parking areas, before the placement of base rock.

Structural Fill:

Structural fill is defined as any soil placed under buildings or any other load bearing-areas. Structural fill placed under footings and slab on grade should be placed in thin horizontal lifts not exceeding eight inches and compacted to a minimum ninety-five percent (95%) of its maximum dry density (Modified Proctor ASTM D1557). The fill material should be placed within two to three percent of the optimum moisture content.

Fill under pavements should also be placed in lifts approximately eight inches in thickness, and compacted to a minimum of ninety percent (92%) of its maximum dry density (Modified Proctor ASTM D1598), except for the top twelve (12) inches which should be compacted to ninety-five percent (95%) of the maximum dry density.

We recommend that structural fill consist of a well graded granular material having a maximum size of two inches and no more than five percent (5%) fines passing the #200 sieve, based on the ¾ inch fraction. It is recommended that any structural fill planned for onsite use, be submitted for approval prior to import.

The placement and compaction of structural fill should be observed by a representative from our office to verify that fill has been placed and compacted in accordance with the approved project plans and specifications.

It should be noted that the depth of excavation to competent soil at foundation footings and floor slab areas could be greater or less than anticipated depending on conditions encountered. Our test pits provide general information about subsurface soil and groundwater conditions.

Wet Weather Construction & Moisture Sensitive Soils:

Field observations and laboratory testing indicates that soil encountered at the site consists of moisture sensitive Silt and lean Clay. As such in an exposed condition moisture sensitive soil can become disturbed during normal construction activity, especially when in a wet or saturated condition. Once disturbed, in a wet condition, these soils will be unsuitable for support of foundations, floor slabs and pavements.

Therefore, where soil is exposed and will support new construction, care must be taken not to disturb their condition. If disturbed soil conditions develop, the affected soil must be removed and replaced with structural fill. The depth of removal will be dependent on the depth of disturbance developed during construction. Covering the excavated area with plastic and refraining from excavation activities during rainfall will minimize the disturbance and decrease the potential degradation of supportive soils.

Earthwork grading and foundation construction will be difficult during the wet winter and spring seasons. Based on this condition we suggest that grading and foundation construction be completed during the drier summer and fall seasons.

Foundations

Based on the encountered subsurface soil conditions, preliminary building design criteria, and assuming compliance with the preceding *Site Preparation and Grading* section, the proposed building may be supported on conventional shallow spread footings bearing entirely on six inches of compacted granular structural fill.

Individual spread footings or continuous wall footings providing support for the proposed commercial building and pump island canopy may be designed for a maximum allowable bearing value of two thousand (2000) pounds per square foot (psf).

Footings for a one level structure should be at least twelve (12) inches in width. Footings for a two-level structure should be a minimum of fifteen (15) inches in width. In either case, all footings should extend to a depth of at least eighteen (18) inches below the lowest adjacent finished sub grade for lateral support and frost heave considerations.

These basic allowable bearing values are for dead plus live loads and may be increased one-third for combined dead, live, wind, and seismic forces. It is estimated that total and differential footing settlements for the relatively light building will be approximately one-half and one-quarter inches, respectively.

Lateral loads can be resisted by friction between the foundation and the supporting sub grade or by passive earth pressure acting on the buried portions of the foundation. For the latter, the foundations must be poured "neat" against the existing soil or back filled with a compacted fill meeting the requirements of structural fill.

- Passive Pressure = 300 pcf equivalent fluid weight
- Coefficient of Friction = 0.40

We recommend that all footing excavations be observed by a representative of Earth Engineering, Inc. prior to placing forms or rebar, to verify that sub grade support conditions are as anticipated in this report, and/or provide modifications in the design as required.

Slab on Grade

The sub-grade for all concrete floor slab areas should be compacted to a dense non-yielding condition prior to the placement of base rock. It is important to note that the existing sub-grade soil may become too wet to re-compact due to weather conditions. If supportive soils become saturated it may be necessary to remove the unsuitable material and replace it with imported granular structural fill.

Interior floor slabs should be provided with a minimum of six inches of compacted granular structural fill after compacting the sub-grade. In areas where moisture is undesirable, a vapor barrier such as a 8-mil plastic membrane should be placed beneath the slab.

Temporary Excavations

The following information is provided solely as a service to our client. Under no circumstances should this information be interpreted to mean that Earth Engineering Inc. is assuming responsibility for construction site safety or the contractor's activities; such responsibility is not being implied and should not be inferred.

In no case should excavation slopes be greater than the limits specified in local, state and federal safety regulations. Based on the information obtained from our field exploration and laboratory testing, the site soils expected to be encountered in excavations, very stiff to hard Silt would be classified as a Type "A" soil by OSHA guidelines.

Therefore, temporary excavations and cuts greater than four feet in height, should be sloped at an inclination no steeper than 3/4H:1V (horizontal:vertical) for type "A" soils. If slopes of this inclination, or flatter, cannot be constructed or if excavations greater than ten feet in depth are required, temporary shoring will be necessary.

Infiltration Testing

During August of 2023, infiltration testing was performed at two locations at four and one half and six feet below the existing ground surface. The approximate location of the infiltration tests are shown on the *Site Plan, Figure 2*.

Infiltration testing was conducted in general accordance with standard engineering practices. The Encased Falling Head Test consists of driving a fifteen (15) inch long, six-inch diameter pipe six inches into the exposed ground surface at the bottom of the test pit. The pipe is filled with water as the soil around the bottom and below the pipe is saturated for several hours. The pipe is filled again, and the amount of time required for the water to fall, per inch, for six inches, is recorded. This step is performed a minimum of three times. The test results are averaged and calculated in inches per hour.

Testing yielded infiltration rates that ranged from 0.1 to 0.25 inches per hour. Based on these infiltration rates and the very stiff to hard soil conditions encountered, it is our opinion on-site soil is not conducive to infiltration. Alternative methods will need to be employed for stormwater control.

Site Drainage

The site should be graded so that surface water is directed off the site. Water should not be allowed to stand in any area where buildings or slabs are to be constructed. Loose surfaces should be sealed at the end of each workday by compacting the surface to reduce the potential for moisture infiltration into the soils. Final site grades should allow for drainage away from the building foundation. The ground should be sloped at a gradient of three percent for a distance of at least ten feet away from the buildings.

We recommend that a footing drain be installed around the perimeter of the building just below the invert of the footing with a gradient sufficient to initiate flow. Under no circumstances should the roof down spouts be connected to the footing drain system. We suggest that clean outs be installed at several accessible locations to allow for the periodic maintenance of the footing drain system. Details for the footing drain have been included on *Figure 3, Typical Footing Drain Detail*.

Utility Support and Back Fill

Based on the conditions encountered, the soil to be exposed by utility trenches should provide adequate support for utilities. Utility trench backfill is a concern in reducing the potential for settlement along utility alignments, particularly in pavement areas. It is also important that each section of utility line be adequately supported in the bedding material. The back fill material should be hand tamped to ensure support is provided around the pipe haunches.

Fill should be carefully placed and hand tamped to about twelve inches above the crown of the pipe before any compaction equipment is used. The remainder of the trench back fill should be placed in lifts having a loose thickness of ten inches.

A typical trench backfill section and compaction requirements for load supporting and non-load supporting areas is presented on *Figure 4, Utility Trench Backfill Detail*. Trench back fill may consist of imported granular fill provided the material is approved, placed and compacted near the optimum moisture content.

Imported granular material or on-site soil to be used as backfill should be submitted to our laboratory at least one week prior to construction so that we can provide a laboratory proctor for field density testing. If native soil is planned for use as backfill, additional testing may be required to determine the suitability of the material.

Pavements

The durability of pavements is related in part to the condition of the underlying sub grade. To provide a properly prepared sub grade for pavements, we recommend the sub grade be treated and prepared as described in the *Site Preparation and Grading* section of this report.

It is possible that some localized areas of soft, wet or unstable sub grade may still exist after this process. Before placement of any base rock, the sub grade should be compacted with suitable compaction equipment. Yielding areas that are identified should be excavated to firm material and replaced with compacted one and one quarter inch-minus clean-crushed rock. The following pavement sections are recommended for the proposed pavement areas:

- Entrance Driveway & Truck Turnaround - Four inches of Asphalt Concrete (AC) over ten inches of compacted Crushed Rock Base (CRB), over a geo-grid consisting of Tensar BX 1200 or equivalent.
- Parking Stalls for Automobiles - Three inches of Asphalt Concrete (AC) over eight inches of compacted Crushed Rock Base (CRB) material.

The geo-grid should be placed directly on the sub grade surface of the driveway prior to placement of base rock. Appropriate geo-textiles have been designed to increase the strength of the sub grade and extend pavement life.

Asphaltic Cement (AC) and Crushed Rock Base (CRB) materials should conform to WSDOT specifications. All base rock should be compacted to at least ninety-five percent (95 %) of the ASTM D1557-91 laboratory test standard.

We recommend that a minimum of eight inches of compacted CRB be placed below all exterior slabs. Exterior concrete slabs that are subject to vehicle traffic loads should be at five inches in thickness. It is also suggested that nominal reinforcement such as "6x6-10/10" welded wire mesh be installed, near midpoint, in new exterior concrete slabs and paving.

Additional Services & Earthwork Monitoring

Earth Engineering, Inc. will be available to provide consultation services related to review of the final design to verify that the recommendations within our purview have been properly interpreted and implemented in the approved construction plans and specifications. A representative from our office will be available to attend a pre-construction meeting to discuss and/or clarify all geotechnical issues related to the proposed project.

In addition, it is suggested that our office be retained to provide geotechnical services during construction to observe compliance with the design concepts and project specifications and to allow design changes in the event subsurface conditions differ from those anticipated. Our construction services would include monitoring and documenting the following:

- Verify that site has been adequately stripped of organic materials.
- Observe the condition of exposed bearing soils at the building areas.
- Laboratory proctor tests for structural fill materials.
- Observe compaction and provide density testing of structural fill.
- Observe compaction and provide density testing of utility trench backfill.
- Provide footing inspection at the building & canopy footings to verify soil bearing capacity.
- Verify the installation of all building and site drainage elements.
- Provide density testing of the asphalt driveway and parking areas.

LIMITATIONS

Our recommendations and conclusions are based on the site materials observed, selective laboratory testing, engineering analyses, the design information provided to Earth Engineering, Inc. and our experience as well as engineering judgment. The conclusions and recommendations are professional opinions derived in a manner consistent with that level of care and skill ordinarily exercised by other members of the profession currently practicing under similar conditions in this area. No warranty is expressed or implied.

The recommendations submitted in this report are based upon the data obtained from the test pits. Soil and groundwater conditions may vary from those encountered. The nature and extent of variations may not become evident until construction. If variations do appear, Earth Engineering, Inc. should be requested to reevaluate the recommendations contained in this report and to modify or verify them in writing prior to proceeding with the proposed construction.

VICINITY MAP

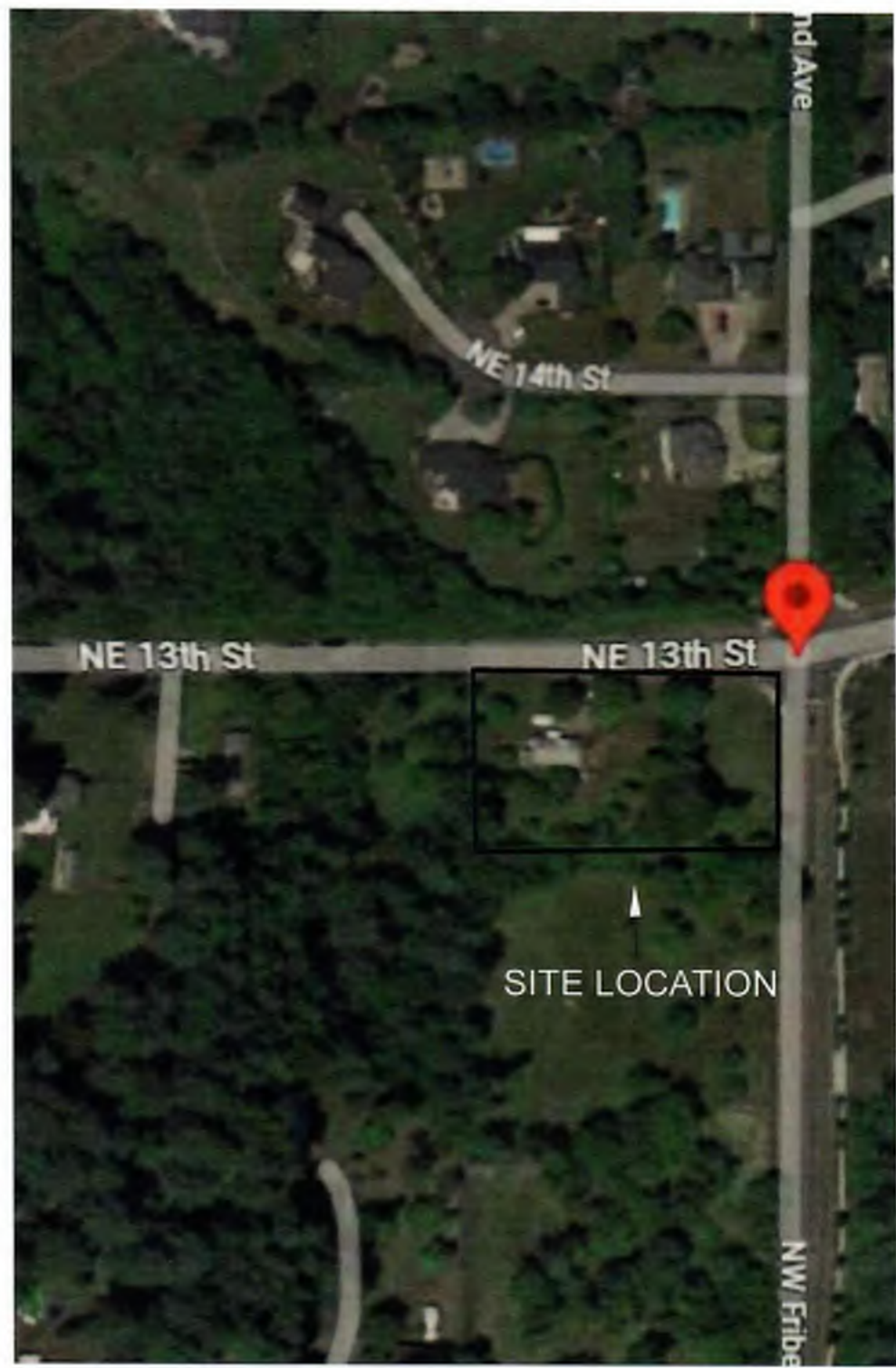

Earth Engineering
GEOTECHNICAL & ENVIRONMENTAL SERVICES

CLIENT:	TAZ KHAN	DRAWN:	EG
PROJECT:	13TH STREET GAS STATION NE 13TH ST & NW FRIBERG-STRUNK ST CAMAS, WA	DATE:	09/2023
		FIGURE:	1
		PRO. #:	G26-0723

SITE PLAN

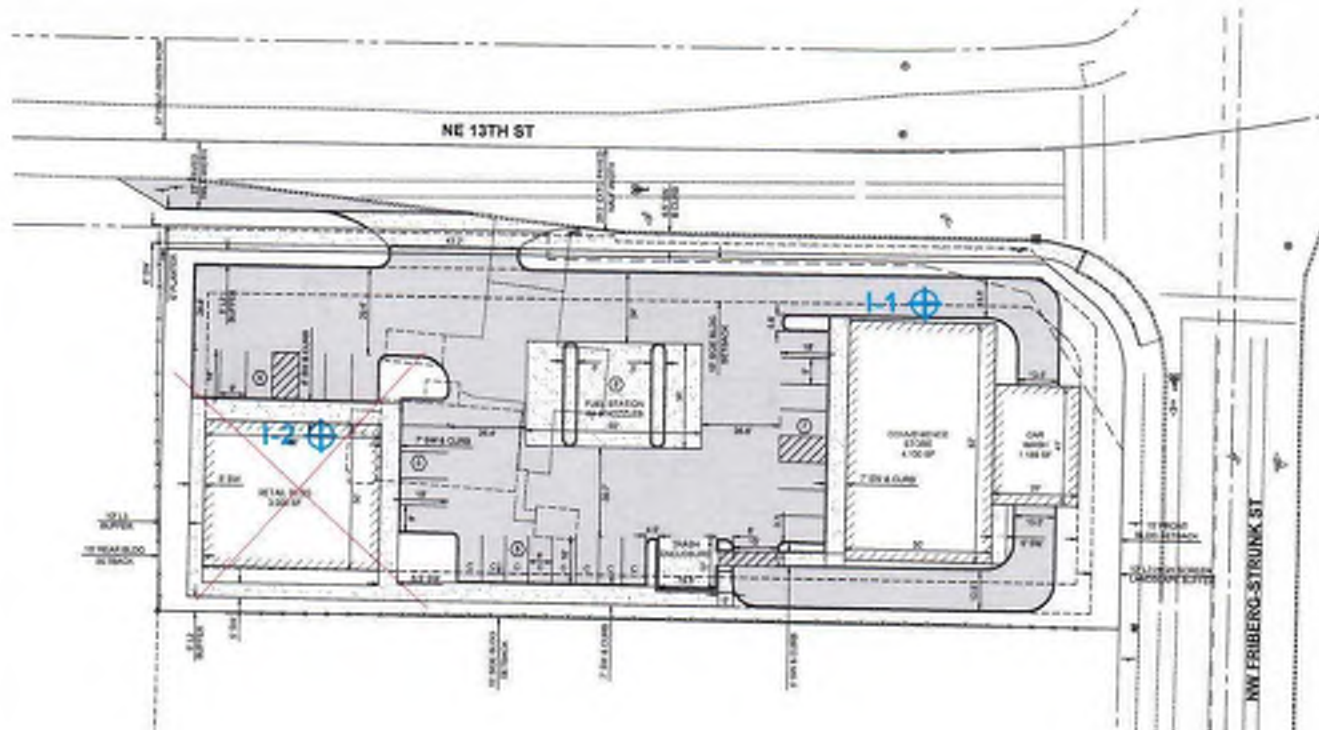

LEGEND

I-1 ⊕ Approximate Infiltration Test Location



NTS



Earth Engineering
GEOTECHNICAL & ENVIRONMENTAL SERVICES

CLIENT: TAZ KHAN

DRAWN: EG

PROJECT:
13TH STREET GAS STATION
NE 13TH ST & NW FRIBERG -STRUNK ST
CAMAS, WA

DATE: 09/2023

FIGURE: 2

PRO. #: G26-0723

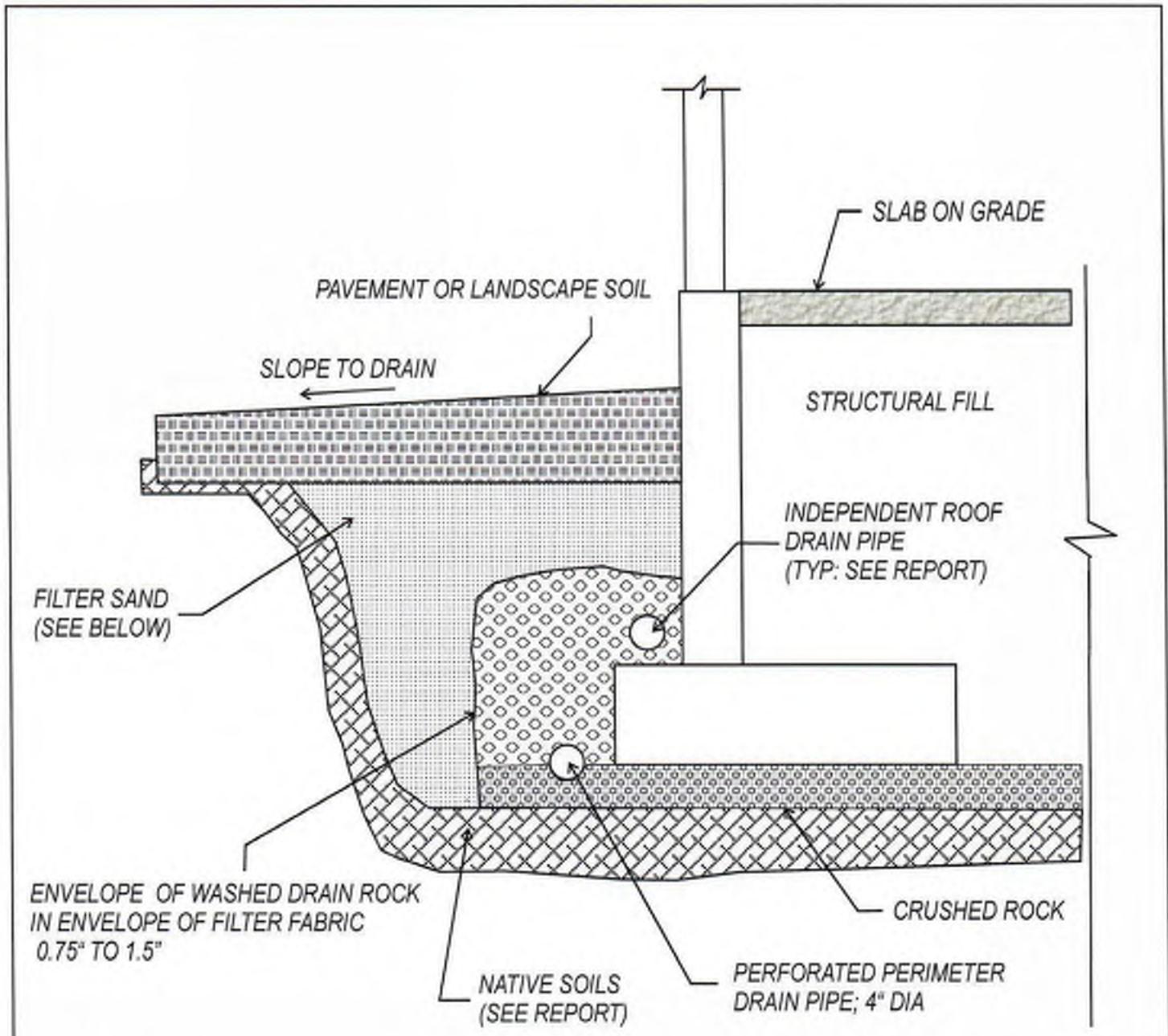

NOTES:

1. FILTER SAND - FINE AGGREGATE FOR PORTLAND CEMENT; SECTION 9=03.1(2)
2. PERFORATED OR SLOTTED RIGID PVC PIPE WITH A POSITIVE DRAINAGE GRADIENT
3. FILTER FABRIC OPTIONAL IF FILTER SAND USED

TYPICAL FOOTING DRAIN DETAIL

Not to Scale

 <p>Earth Engineering, Inc. GEOTECHNICAL & ENVIRONMENTAL SERVICES</p>	CLIENT: 13TH STREET GAS STATION	DRAWN: DB
	PROJECT: COMMERCIAL BUILDING	DATE: 07/2023
	NE 13TH ST. & NW FRIBERG-STRUCK ST. VANCOUVER, WA	FIGURE: 3
		PRO. #: G26-0723

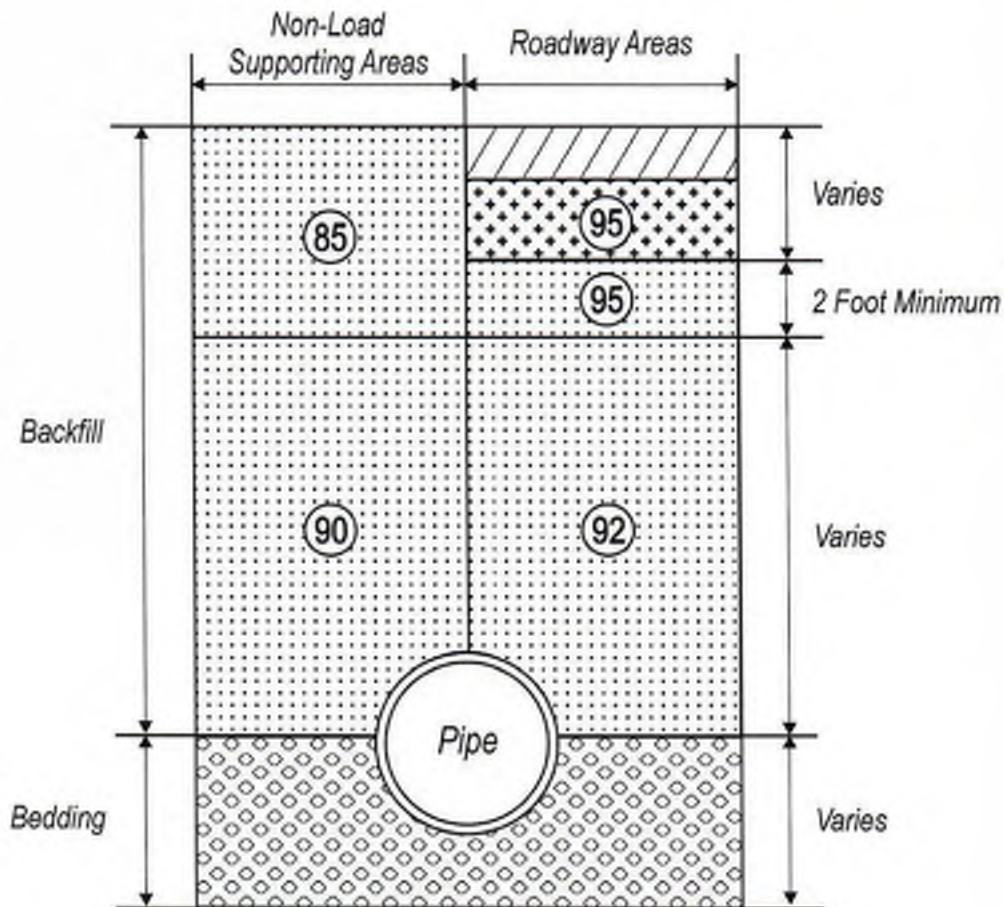

LEGEND



Asphalt or Concrete Pavement



Roadway Base Material or Base Rock



Backfill: Compacted on-site soil or imported select fill material as described in the site preparation of the general Earthwork Section of the attached report text.

92

Minimum percentage of maximum Laboratory Dry Density as determined by ASTM Test method D1557 (Modified Proctor), unless otherwise specified in the attached report text.



Bedding Material: Material type depends on type of pipe and laying conditions. Bedding should conform to the manufacturer's recommendations for the type of pipe selected.

UTILITY TRENCH BACKFILL DETAIL

Not to Scale



Earth Engineering, Inc.

GEOTECHNICAL & ENVIRONMENTAL CONSULTANTS

CLIENT: 13TH ST. GAS STATION
PROJECT: COMMERCIAL BUILDING
NE 13TH ST. & NW FRIBERG-STRUNK
CAMAS, WA

DRAWN: DB
DATE: 07/2023
FIGURE: 4
PRO. #: G26-0723

APPENDIX A

(FIELD EXPLORATION)

FIELD EXPLORATION

Our field exploration was performed on August 4th 2023. Subsurface conditions at the site were explored by excavating two test pits. The test pits were excavated to a maximum depth of ten and one half (10.5) feet below the existing ground surface. The test pits were excavated using a track-hoe.

The test pits were located by pacing from property features. The locations are shown on the Site Plan, Figure 2. Field exploration was monitored by an Earth Engineering, Inc. representative, who classified the soils that we encountered and maintained a log of each test pit, obtained representative samples, and observed pertinent site features. Representative soil samples were placed in closed containers and returned to the laboratory for further examination and testing.

All samples were identified using the Standard Classification of Soils for Engineering Purposes (ASTM D2487-93) in accordance with the Unified Soil Classification System (USCS), which is presented on Plate A-1. The test pit log and boring logs are presented in Appendix A. The final log represents our interpretations of the field logs and the results of the laboratory tests on field samples.

UNIFIED SOIL CLASSIFICATION SYSTEM LEGEND

MAJOR DIVISIONS			GRAPH SYMBOL	LETTER SYMBOL	TYPICAL DESCRIPTION
Coarse Grained Soils	Gravel and Gravelly Soils More Than 50% Coarse Fraction Retained on No 4 Sieve	Clean Gravels (little or no fines)		GW	Well-Graded Gravels, Gravel-Sand Mixtures Little or no Fines
				GP	Poorly-Graded Gravels, Gravel-Sand Mixtures, Little or no Fines
		Gravels with Fines (appreciable amount of fines)		GM	Silty Gravels, Gravel-Sand-Silt Mixtures
			GC	Clayey Gravels, Gravel-Sand-Clay Mixtures	
	Sand and Sandy Soils More Than 50% Coarse Fraction Passing No 4 Sieve		Clean Sand (little or no fines)		SW
				SP	Poorly-Graded Sands, Gravelly Sands Little or no Fines
Sands with Fines (appreciable amount of fines)			SM	Silty Sands, Sand-Silt Mixtures	
		SC	Clayey Sands, Sand-Clay Mixtures		
Fine Grained Soils	Sils and Clays	Liquid Limit Less than 50		ML	Inorganic Silts and Very Fine Sands, Rock Flour, Silty-Clayey Fine Sands; Clayey Silts w/ slight Plasticity
				CL	Inorganic Clays of Low to Medium Plasticity; Gravelly Clays, Sandy Clays, Silty Clays, Lean
				OL	Organic Silts and Organic Silty Clays of Low Plasticity
	Sils and Clays	Liquid Limit Greater than 50		MH	Inorganic Silts, Micaceous or Diatomaceous Fine Sand or Silty Soils
				CH	Inorganic Clays of High Plasticity, Fat Clays
				OH	Organic Clays of Medium to High Plasticity, Organic Silts
Highly Organic Soils				PT	Peat, Humus, Swamp Soils with High Organic Contents

Topsoil		Humus and Duff Layer
Fill		Highly Variable Constituents



Earth Engineering Inc.

GEOTECHNICAL & ENVIRONMENTAL SERVICES

CLIENT: 13TH STREET GAS STATION

DRAWN: DB

PROJECT: COMMERCIAL BUILDING
NE13TH ST. & NW FRIBERG-STRUNK ST.
CAMAS, WA

DATE: 07/2023

PLATE: A1

PRO. #: G26-0723

LOG OF TEST PIT
(Northeast)

I-1

ELEVATION: +/- 239 feet
EXPLORATORY EQUIPMENT: TRACK HOE
DATE: 08/04/2023

DEPTH IN FEET	SAMPLES	SOILS CLASSIFICATION	LITHOLOGY (USGS)	COLOR	MOISTURE	CONSISTENCY	MOISTURE CONTENT % OF DRY WEIGHT	PERCENT PASS NUMBER 200
1	•	6" Topsoil		Light Brown			14	-
2								
3								
4								
5	•	 - Field infiltration rate of 0.25 inches per hour Silt (ML) trace sand			Damp to Wet	Very Stiff to Hard	18	-
6								
7								
8								
9								
10	•	(Native)		Grey Brown			26	-

Bottom of test pit at 10.5 feet below existing ground surface.
No groundwater encountered.



CLIENT:	TAZ KHAN	DRAWN:	DB
PROJECT:	13TH ST GAS STATION NE 13TH ST & NW FRIBERG-STRUNK ST CAMAS, WA	DATE:	09/2023
		PLATE:	A-2
		PRO. #:	G26-0723

LOG OF TEST PIT
 (Central West)

I-2

ELEVATION: +/- 240 feet

EXPLORATORY EQUIPMENT: TRACK HOE

DATE: 08/04/2023

DEPTH IN FEET	SAMPLES	SOILS CLASSIFICATION	LITHOLOGY (USGS)	COLOR	MOISTURE	CONSISTENCY	MOISTURE CONTENT % OF DRY WEIGHT	PERCENT PASS NUMBER 200		
1		8" Topsoil								
2	●	Silt (ML)		Light Brown to Dark Brown	Damp to Sat	Very Stiff to Hard	13	-		
3										
4										
5										
6	●	▧ - Field infiltration rate of 0.1 inches per hour					43			
7		(Native)								
8		lean Clay (CL)		Light Brown Grey	Sat	Very Stiff to Hard				
9										
10	●									

Bottom of test pit at 10.0 feet below existing ground surface.
No groundwater encountered.

Earth Engineering, Inc.

GEOTECHNICAL & ENVIRONMENTAL SERVICES

CLIENT: TAZ KHAN

DRAWN: DB

PROJECT:

DATE: 09/2023

 13TH ST GAS STATION
 NE 13TH ST & NW FRIBERG-STRUNK ST
 CAMAS, WA

PLATE: A-3

PRO. #: G26-0723

SEPARATOR SHEET

APPENDIX D

Operations and Maintenance Manual

Stormwater Sewer System Operations & Maintenance Manual

JUNE 2022

City of Camas
Stormwater Division | Public Works



Page left blank intentionally

Table of Contents

Introduction	5
Background	5
Purpose	5
Manual Layout	6
Emergent Treatment Technologies	6
Mosquito Control	6
Material Disposal and Spills	6
Vegetated Facilities.....	8
Biofiltration Swale.....	8
Wet Biofiltration Swale.....	9
Filter Strip	10
Detention Pond.....	11
Wet Pond	12
Infiltration Facility.....	13
Rain Garden	14
Bioretention.....	16
Conveyance Ditch	17
Stormwater Structures	18
Catch Basin.....	18
Field/Ditch Inlet	19
Manhole.....	21
Debris Barrier.....	23
Sediment Trap.....	24
Energy Dissipater	26
Discharge Point	27
Oil/Water Separators.....	28
Flow Control Structures/Flow Restrictors	29
Storm Sewer Pipe	30
Closed Detention System.....	31

2022 Stormwater Sewer System Operations & Maintenance Manual | City of Camas, Washington

Drywell	32
Pond Leveler System.....	33
Dispersion Trench	34
Special Facilities	35
Manufactured Media Filter	35
Permeable Pavement	36
Modular Wetland.....	37
Tree Box Filter.....	38
Miscellaneous Items	39
Fences, Gates and Water Quality Signs	39
Access Roads and Easements	41
Pavement Sweeping	42
Repair/Replacement Activities	43
Minor Culvert Repair (Not in a Stream).....	43
Major Culvert Repair (at a Stream Crossing)	43
Vegetation Management.....	44
Integrated Pest Management (IPM) Principles	44
Plants and Groundcover	45
References	46

Introduction

Background

All public and privately owned, roads, parking lots, residential developments, commercial or industrial developments, or school facilities have various components that make up a storm system. These components consist of conveyance pipes, catch basins, manholes, roadside ditches, stormwater facilities (such as bioswales, detention ponds, wet ponds, treatment filters, etc.), landscaping and any other structure that collects, conveys, controls, and/or treats stormwater. Regardless of the component, all storm systems eventually discharge into 'waters of the state' which are streams, rivers, lakes, and wetlands.

Under the Federal Clean Water Act (FCWA) and in compliance with the Department of Ecology's NPDES Phase II Permit, 'waters of the state' are to be protected from contamination. This in turn protects threatened and endangered species under the Federal Endangered Species Act (FESA).

One way to protect 'waters of the state' is to provide the proper maintenance of all storm system components. It is the responsibility of the City of Camas (City) to ensure that all components of the public storm system be properly maintained and operated. The City is responsible for those components that are located within the City's right-of-way, such as the conveyance pipes, manholes, catch basins, roadside ditches, and stormwater facilities. A large part of the stormwater facilities in the City are privately owned and maintained by the property owners. These property owners include, but are not limited to, Homeowners Associations (HOAs), school district, businesses, and commercial/industrial site owners.

Purpose

This manual is intended to help, both public and private stormwater facility maintenance operators, meet the requirements of City Municipal Code 14.02.090 for proper maintenance and operation of the various storm system components. Proper maintenance will help to assure that:

- Stormwater facilities operate as they were designed;
- Storm systems are cleaned of the pollutants that they trap, such as sediment and oils, so that storm systems are not overwhelmed and become pollutant sources;
- Pollutant sources are removed, or minimized, prior to entering the storm system.

Along with keeping a site from flooding, properly maintained storm system can help reduce surface water and groundwater pollution. Most sites have some type of stormwater control component designed to limit the environmental and flooding damage caused by stormwater runoff. These components require more labor intensive maintenance than a system of pipes and catch basins.

Manual Layout

This manual is broken out into various best management practice (BMP) maintenance components. For each BMP maintenance component, this manual will:

- Briefly describe the component type, e.g. facility or activity.
- Describes potential maintenance issues and/or problems.
- Describes conditions when maintenance is required.
- Minimum performance standards and suggested maintenance methods.

Additional information may be found in other manuals, such as the Washington Department of Ecology's *Stormwater Management Manual for Western Washington (SWMMWW)*, Vols. V, and Ecology's LID manual.

Inspection of a stormwater facility will determine if conditions require a maintenance action. The maintenance standard is not the required condition at all times. Exceeding a condition, between inspections and/or maintenance, does not automatically constitute a violation of these standards. The inspection and maintenance schedules should be adjusted to minimize the length of time that a facility is in a condition that requires maintenance.

Emergent Treatment Technologies

Some stormwater treatment facilities are designed and installed with emerging technologies that are not standard at the time of their installation. If not found in this manual, a treatment facility may be an emerging technology approved by Washington Department of Ecology; the maintenance standards can be found at [Emerging Stormwater Treatment Technologies](#).

Mosquito Control

Mosquitoes are annoying and sometimes pose a serious risk to public health. They can transmit diseases such as West Nile Virus and equine encephalitis. Above-ground stormwater facilities should be designed to allow water to flow through or infiltrate in less than 48 hours. Presence of mosquitos in a stormwater facility may indicate a clogged outlet, compromised infiltration capacity, or other defect that should trigger inspection and may require maintenance.

If mosquitos are identified during a stormwater facility maintenance or inspection and are a concern, a request to the Clark County Mosquito Control District for service or information regarding mosquito control can be made online at [Mosquito Control District](#) or at the 24-hour request line, 360-397-8430.

Material Disposal and Spills

The disposal of waste, e.g. sediment or standing water, from the maintenance of the stormwater facilities and storm system components shall be conducted in accordance with federal, state, and local regulations, including the Solid Waste Handling Standards chapter [173-350 WAC](#), Minimum Functional Standards for Solid

2022 Stormwater Sewer System Operations & Maintenance Manual | City of Camas, Washington

Waste Handling chapter [173-304 WAC](#) and [Appendix IV-B](#): Management of Street Waste Solids and Liquids of the SWMMWW. Dangerous waste must be handled following, Dangerous Waste Regulations chapter [173-303 WAC](#). Vegetation to be recycled and disposed of at local receptacle locations.

For major spills, coordinate removal/cleanup with the City at 360-817-1563 and notify Department of Ecology at 360-407-6300.

Vegetated Facilities

Biofiltration Swale

Biofiltration swales use grass or other dense vegetation to filter sediment and oily materials out of stormwater. Usually, they look like flat-bottomed channels with grass growing in them. As water passes through the vegetation, pollutants are removed through the effects of filtration, infiltration and settling.

See SWMMWW [Appendix V-A](#), Table V-A.8 for biofiltration swale maintenance standards. If available, reference record drawings for seed mix and groundcover replacements, or see SWMMWW [BMP T9.10, Tables V-7.3 and V-7.4](#). Presence of cattails is a sign that that there is water ponding and the facility is not functioning as design. Cattails will need to be removed and further investigation may be required.



Wet Biofiltration Swale

A wet biofiltration swale is a variation of basic biofiltration swale for use where the centerline slope is slight, groundwater table are high, or a continuous low base flow is likely to result in wet soil conditions for long periods of time. Where continuously wet soil exceeds about 2 weeks, typically grasses will die. Thus, vegetation specifically adapted to wet soil conditions is needed. Different vegetation requires modification of several of the design and maintenance requirements from the basic biofiltration swale.

See SWMMWW [Appendix V-A](#), Table V-A.9 for wet biofiltration swale maintenance standards. If available, reference record drawings for seed mix and groundcover replacements, or see SWMMWW [BMP T9.20, Table V-7.5](#). Removal of cattail is required when vegetation is crowded out by very dense clumps of cattails, prevents water flow, or alters the designed functionality.



Filter Strip

Filter strips are linear strips of grass that remove sediment and oils from stormwater by filtering it. Stormwater is treated as it sheet flows across the filter strip. Usually, filter strips are placed along the edge of linear paved areas, such as parking lots and roads. Where designed filter strips are installed; road shoulders should only be graded to maintain level flow off the road.

See SWMMWW [Appendix V-A](#), Table V-A.10 for filter strip maintenance standards. If available, reference record drawings for seed mix replacement, or see SWMMWW [BMP T9.10, Table V-7.3](#).



Detention Pond

Detention pond facilities are designed to hold and slowly release stormwater by use of a pond with a specially designed control structure. Styles vary greatly from well-manicured to natural appearing. Generally, native vegetation is preferred for reduced maintenance and enhance wildlife habitat. Some facilities are designed to appear as natural water bodies or are in a park-like setting.

See SWMMWW [Appendix V-A](#), Table V-A.1 for detention pond maintenance standards. If available, reference record drawings for seed mix replacement, or see SWMMWW [BMP D.1, Table V-12.3](#). Removal of cattail is required when vegetation is crowded out by very dense clumps of cattails, prevents water flow, or alters the designed functionality.



Wet Pond

A wet pond is an open basin that retains a permanent pool of water year-round or only during the wet season. The volume of the wet pond allows sediment and other pollutants to settle out of the runoff. Wetland vegetation is typically planted within the wet pond to provide additional treatment through nutrient removal. Detention quantity control can be provided with additional temporary storage volume above the permanent pool elevation.

See SWMMWW [Appendix V-A](#), Table V-A.11 for wet pond maintenance standards. If available, reference record drawings for seed mix and plants replacement, or see SWMMWW [BMP D.1, Table V-12.3](#) for seed mix and [BMP T10.10, Table V-8.1](#) for plants. Removal of cattails is required when vegetation is crowded out by very dense clumps of cattails, prevents water flow, or alters the designed functionality.



Infiltration Facility

Infiltration facilities dispose of water by holding it in an area where it can soak into the ground. These are open facilities that may either drain rapidly and have grass bases or have perpetual ponds where water levels rise and fall with stormwater flows. Infiltration facilities may be designed to handle all of the runoff from an area or they may overflow and bypass larger storms.

Since the facility is designed to pass water into the ground, generally after passing through a sediment trap/manhole, anything that can cause the base to clog will reduce the performance and is a large concern. Generally, infiltration basins are managed like detention ponds, but with greater emphasis on maintaining the capacity to infiltrate stormwater.

See SWMMWW [Appendix V-A](#), Table V-A.2 for infiltration facility maintenance standards. If available, reference record drawings for seed mix replacement, or see SWMMWW [BMP D.1, Table V-12.3](#). Removal of cattail is required when vegetation is crowded out by very dense clumps of cattails, prevents water flow, or alters the designed functionality.



Rain Garden

Rain gardens are non-engineered, shallow, landscaped depressions with compost-amended soils and adapted plants. The depression temporarily stores stormwater runoff from adjacent areas. Some or all the influent stormwater passes through the amended soil profile and into the underlying native soil. Stormwater that exceeds the storage capacity is designed to overflow to an adjacent drainage system.

If available, reference record drawings for plant replacements, or see [Rain Garden Handbook for Western Washington, Appendix A](#) for recommendation on rain garden plants. Presence of cattails is a sign that there is water ponding and the facility is not functioning as design. Cattails will need to be removed and further investigation may be required.



2022 Stormwater Sewer System Operations & Maintenance Manual | City of Camas, Washington

Rain Garden			
Maintenance Component	Defect or Problem	Conditions When Maintenance Is Needed	Minimum Maintenance Required
General	Trash and Debris	Evidence of trash and debris	Remove trash and debris
Side slopes	Erosion	Persistent soil erosion on slopes	Replenish mulch areas throughout rain garden - on the sides and bottom of the rain garden and around the perimeter (and on berm if applicable).
Bottom area	Sediment	Visible sediment that reduces drainage rate	Remove sediment accumulation
		Sediment deposited from water entering the rain garden	Remove sediment, determine the source, and stabilize area
	Leaves	Matted accumulation of leaves reducing drainage rate	Remove leaves
Ponded water	Ponding	Ponded water remains for more than 3 days after the end of a storm	Remove sediment, leaf litter and/or debris accumulation
Pipe inlet/outlet	Pipe	Water is backing up in pipe	Clear pipes of sediment and debris with snake and/or flush with water
		Damaged or cracked drain pipes	Repair or seal cracks, or replace as needed
Inlet rock pad	Erosion	Rock or cobble is removed, missing and flow is eroding soil.	Replace rock and reestablish pad
Weeds	Weeds	Weeds are present	Remove weeds and apply mulch after weeding
Vegetation	Dying Vegetation	Dying, dead or unhealthy plants	Remove diseased plants or plant parts and dispose, then replace
	Sight Distance	Vegetation reduces sight distances and sidewalk	Keep sidewalks and sight distances on roadways clear
	Blockage	Vegetation is crowding inlets and outlets	Remove vegetation crowding inlets and outlets
	Poor Vegetation Growth	Yellowing, poor growth, poor flowering, spotting or curled leaves, weak roots, or stems	Test soil to identify specific nutrient deficiencies. Do not use synthetic fertilizers Consider selecting different plant for soil conditions
Mulch	Bare Soil	Bare spots are present or mulch depth less than 2 inches	Supplement mulch with hand tools to a depth of 2 to 3 inches, keep mulch away from woody stems.

Bioretention

Bioretention facilities are engineered facilities that store and treat stormwater by filtering it through a specified soil profile. Water that enters the facility ponds in an earthen depression or other basin (e.g., concrete planter) before it infiltrates into the underlying bioretention soil. Stormwater that exceeds the surface storage capacity overflow to an adjacent drainage system. Treated water is either infiltrated into the underlying native soil or collected by an underdrain and discharged. An underdrain system can be comprised of perforated or slotted pipe, wrapped in an aggregate blanket.

See SWMMWW [Appendix V-A](#), Table V-A.21 for bioretention maintenance standards. If available, reference record drawings for plant replacements, or see [LID Technical Guidance Manual for Puget Sound](#), Appendix 1 for plant recommendations. Presence of cattails is a sign that there is water ponding and the facility is not functioning as design. Cattails will need to be removed and further investigation may be required.



Conveyance Ditch

Ditches are often manmade open-channels that convey stormwater runoff. These ditches are maintained to prevent localized flooding.



Conveyance Ditch			
Maintenance Component	Defect or Problem	Conditions When Maintenance Is Needed	Minimum Maintenance Required
General	Sediment	Sediment exceeds 20% of ditch depth or affects the historic or designed hydraulic capacity.	Remove sediment deposits. When finished, ditch should be level from side to side and drain freely in intended direction.
	Standing Water	Excessive standing water in ditch between storms due to ditch not draining freely	If possible, repair cause of poor drainage. This may include but is not limited to the following activities: remove sediment or trash blockages, improve grade of ditch.
	Eroded or Unstable Side Slopes	When grass is sparse, bare or eroded, patches occur in more than 20% of the ditch	Determine why grass growth is poor and correct that condition. Replant with plugs of grass at eight-inch intervals or reseed. If cause is excessive moisture replace grass with wetland plantings.
	Vegetation	Grass is excessively tall (greater than 15 inches). Nuisance weeds and other vegetation start to take over ditch.	Mow vegetation and/or remove nuisance vegetation so that flow is not impeded. Grass should be mowed to a height of 3 to 4 inches.
	Bare Soil	Poor vegetation coverage.	Reseed poor vegetation areas. Reference "Low Grow" seed mix, see SWMMWW BMP C120 Table II-3.4
	Inlet/Outlet Pipes or Culverts	Inlet/outlet area clogged with sediment and/or debris	Remove material so that there is no clogging or blockage in the inlet and outlet area
	Trash and Debris	Any trash and debris which exceed 1 cubic feet per 1,000 square feet. In general, there should be no visual evidence of dumping.	Remove trash and debris from ditch.
	Erosion/Scouring	Eroded or scoured ditch bottom	Permanently stabilize ditch bottom

Stormwater Structures

Catch Basin

A catch basin is an underground concrete structure with a slotted grate that collects stormwater runoff and route it through the underground pipes. Catch basins typically provide a sump below the outlet pipe to allow sediment and debris to settle out of the stormwater runoff. Some catch basins are fitted with a spill control device such as an inverted elbow on the outlet pipe to control grease or oils. The most common tool for cleaning catch basins is a vactor truck which is used to remove sediment and debris from the sump. The sediment and oils if not removed from the catch basins have the potential to pollute downstream waterbodies. Unless you have Occupational Safety and Health Administration (OSHA) approved confined space training and equipment, never enter a catch basin. There is a considerable risk of poisonous gas and injury.

See SWMMWW [Appendix V-A](#), Table V-A.5 for catch basin maintenance standards.

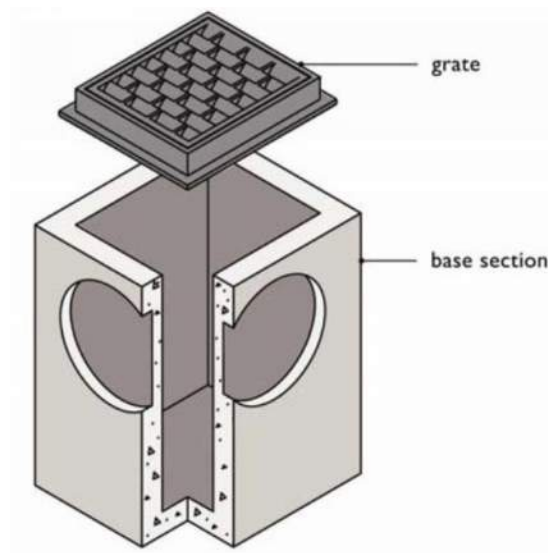

Field/Ditch Inlet

An inlet is a concrete, plastic or steel structure fitted with a slotted grate to collect stormwater runoff and route through underground pipes. A field inlet has a flat grate, and a ditch inlet has an angled grate. These inlets typically provide a sump below the outlet pipe to allow sediment and debris to settle out of the stormwater runoff. Some of these inlets are fitted with a spill control device such as an inverted elbow on the outlet pipe to control grease or oils. The most common tool for cleaning out the inlet is a vactor truck which is used to remove sediment and debris from the sump. The sediment and oils if not removed from the inlet has the potential to pollute downstream water bodies. Unless you have OSHA approved confined space training and equipment, never enter an inlet. There is a considerable risk of poisonous gas and injury.



Field Inlet



Ditch Inlet

2022 Stormwater Sewer System Operations & Maintenance Manual | City of Camas, Washington

Field Inlet/Ditch Inlet			
Maintenance Component	Defect or Problem	Conditions When Maintenance Is Needed	Minimum Maintenance Required
General	Trash & Debris	Trash or debris blocking inletting capacity by more than 10%.	Remove trash or debris blocking grate opening.
		Dead animals or vegetation that could generate odors that could cause complaints or dangerous gases (e.g., methane).	Remove dead animals or vegetation present within the field/ditch inlet.
	Sediment	Sediment has accumulated to within six inches of the invert of the lowest pipe	Remove sediment
	Structure Damage to Frame and/or Top Slab	Top slab has holes larger than 2 square inches or cracks wider than 1/4 inch.	Repair top slab to be free of holes and cracks.
		Frame not sitting flush on top slab, i.e., separation of more than 3/4 inch of the frame from the top slab. Frame not securely attached	Make adjustments so that frame is sitting flush on the riser rings or top slab and is firmly attached.
	Fractures or Cracks in Field Inlet Walls/Bottom	Grout fillet has separated or cracked wider than 1/2 inch and longer than 1 foot at the joint of any inlet/outlet pipe or any evidence of soil particles entering catch basin through cracks.	RegROUT pipe and secure at field inlet wall.
	Settlement/Misalignment	If failure of field inlet has created a safety, function, or design problem.	Replace or repair field inlet to design standards.
	Vegetation	Vegetation growing across and blocking more than 10% of the inlet opening.	Remove vegetation blockage from basin opening.
Contamination and Pollution	Any evidence of oil, gasoline, contaminants, or other pollutants	Identify and remove source. Notify City at (360) 817-1567.	
Metal Grates	Grate Not in Place	Grate is missing or only partially in place. Any open field inlet requires maintenance.	Replace missing grate, cover field inlet
	Grate opening Unsafe	Grate with opening wider than 7/8 inch.	Repair grate opening
	Damaged or Missing.	Grate missing or broken member(s) of the grate.	Replace missing grate or repair broken member(s)

Manhole

Manholes are large cylindrical underground structures usually set at storm sewer pipe connections. Manholes are used in storm sewer system at any change in direction, slope, pipe material or pipe size. Some manholes have sumps and fitted with stormwater flow control structures such as orifices or weirs. Unless you have OSHA approved confined space training and equipment, never enter a manhole. There is a considerable risk of poisonous gas and injury.

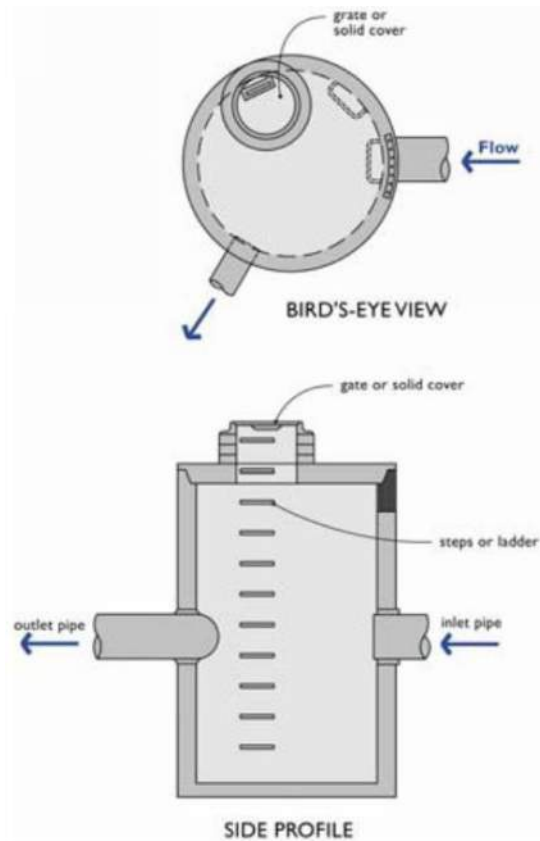

2022 Stormwater Sewer System Operations & Maintenance Manual | City of Camas, Washington

Manhole			
Maintenance Component	Defect or Problem	Conditions When Maintenance Is Needed	Minimum Maintenance Required
General	Trash and Debris	Trash or debris has accumulated to within six inches of the invert of the lowest pipe.	Remove all trash or debris from manhole.
		Trash or debris in any inlet or outlet pipe blocking more than 1/3 of its height.	Remove trash or debris from inlet and outlet pipes.
	Sediment	Sediment has accumulated to within six inches of the invert of the lowest pipe.	Remove all sediment from manhole
	Structure Damage to Frame and/or Top Slab	Top slab has holes larger than 2 square inches or cracks wider than 1/4 inch.	Repair top slab to be free of holes and cracks.
		Frame not sitting flush on top slab, i.e., separation of more than 3/4 inch of the frame from the top slab. Frame not securely attached	Make adjustments so that frame is sitting flush on the riser rings or top slab and is firmly attached.
	Fractures or Cracks in Manhole Walls/Bottom	Grout fillet has separated or cracked wider than 1/2 inch and longer than 1 foot at the joint of any inlet/outlet pipe or any evidence of soil particles entering manhole through cracks.	RegROUT pipe and secure at manhole wall.
	Settlement/Misalignment	If failure of manhole has created a safety, function, or design problem.	Replace or repair manhole to design standards.
Cover	Cover Not in Place	Cover is missing or only partially in place. Any open manhole requires maintenance.	Replace missing cover, cover manhole.
	Locking Mechanism Not Working	Mechanism cannot be opened by one maintenance person with proper tools. Bolts into frame have less than 1/2 inch of thread.	Repair opening mechanism
	Cover Difficult to Remove	One maintenance person cannot remove lid after applying normal lifting pressure.	Make adjustments so that one maintenance person can remove the manhole cover.
Ladder	Ladder Rungs Unsafe	Ladder is unsafe due to missing rungs, not securely attached to basin wall, misalignment, rust, cracks, or sharp edges.	Repair or replace ladder to meet design standards and allow maintenance person safe access.
Control Structure/Flow Restrictor	See Control Structure/Flow Restrictor		

Debris Barrier

Debris barriers and trash racks are barred covers to pipe openings. They prevent large objects from entering pipes and keeps pets and people out of the pipes as well.

See SWMMWW [Appendix V-A](#), Table V-A.6 for debris barrier maintenance standards.

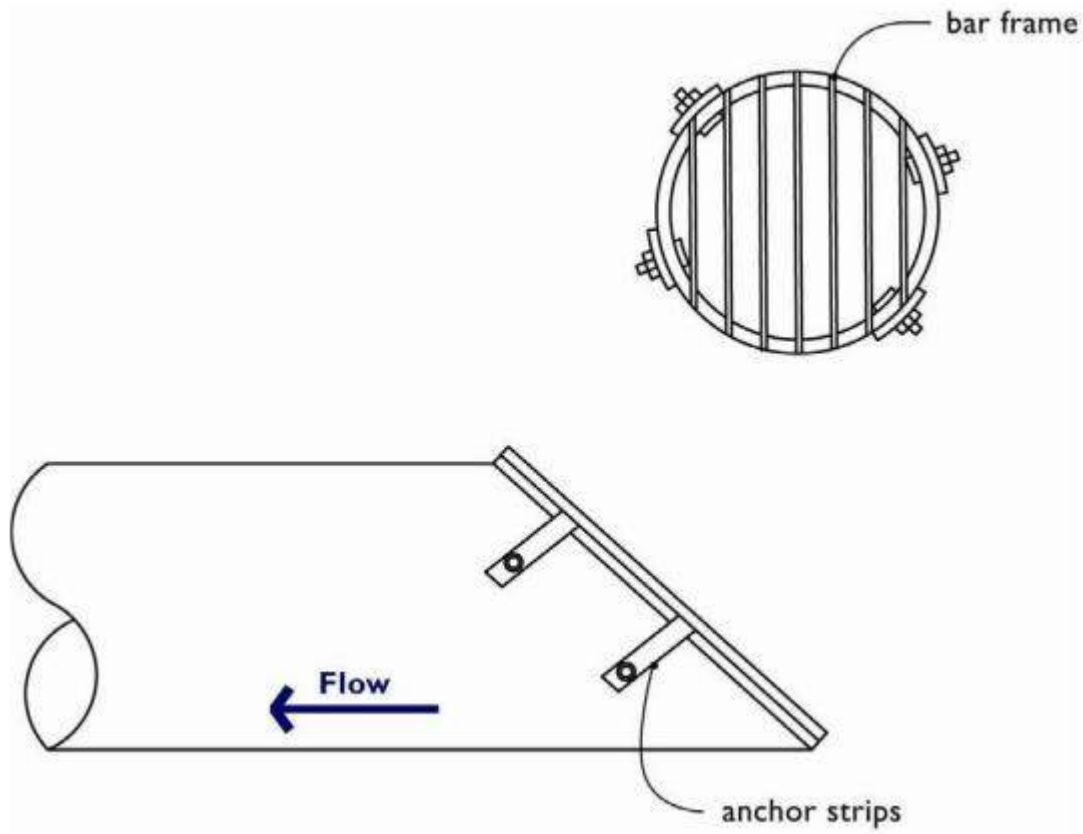

Profile View

Sediment Trap

A sediment trap is a concrete structure typically fitted with slotted grate or multiple slotted grates. The concrete structure provides a storage volume (sump) below the outlet pipe to allow sediment and debris to settle out of the stormwater runoff. A sediment trap can be a fully enclosed concrete structure (above or below ground) with a sump, inlet pipe(s) and outlet pipe.



2022 Stormwater Sewer System Operations & Maintenance Manual | City of Camas, Washington

Sediment Trap			
Maintenance Component	Defect or Problem	Conditions When Maintenance Is Needed	Minimum Maintenance Required
General	Trash and Debris	Trash and debris which is located immediately in front of the sediment trap opening or is blocking the inlet capacity of the basin by more than 10%	Remove trash and debris
		Dead animals or vegetation that could generate odors that could cause complaints or dangerous gases (e.g., methane).	Remove dead animals or vegetation present within the sediment trap.
	Sediment (non-enclosed structure)	Sediment depth exceeds 2 inches.	Remove sediment
	Sediment (enclosed structure)	Sediment depth within 6 inches from lowest invert	Remove sediment
	Fractures or Cracks in Sediment Trap	Grout fillet has separated or cracked wider than 1/2 inch and longer than 1 foot at the joint of any inlet/outlet pipe or any evidence of soil particles entering sediment trap through cracks.	RegROUT pipe and secure at sediment trap wall.
	Settlement/ Misalignment	If failure of sediment trap has created a safety, function, or design problem.	Replace or repair sediment trap to design standards.
	Vegetation	Vegetation growing across and blocking more than 10% of the sediment trap opening	Remove vegetation
	Contaminants and Pollution	Any evidence of oil, gasoline, contaminants, or other pollutants	Remove contaminants and/or pollutants. (Coordinate removal/cleanup with local water quality response agency)
Slotted Grate	Trash and Debris	Trash and debris that is blocking more than 20% of the grate surface inlet capacity	Remove trash and debris from grate
	Damaged or Missing Grate	Grate missing or broken member(s) of the grate	Replace or repair grate to design standards.
Cover (enclosed structure)	Cover Not in Place	Cover is missing or only partially in place.	Replace missing cover
	Cover Difficult to Remove	One maintenance person cannot remove lid after applying normal lifting pressure or latch broken	Make adjustments so that one maintenance person can remove the cover and/or repair broken latch.

Energy Dissipater

Energy dissipaters are critical for preventing erosion at storm drain outfalls. There are a variety of designs, including wire gabion baskets, rock splash pads, trenches, and specially designed pools or manholes. They are installed on or near the inlet or outlet to a closed pipe system to prevent erosion at these locations.

See SWMMWW [Appendix V-A](#), Table V-A.7 for energy dissipater maintenance standards.



Discharge Point

Stormwater facility discharge points may convey drainage from the stormwater facility into open channels, ditches, ponds, wetlands, streams, or lakes. Stormwater facility discharge points need to be assessed to make sure stormwater is not causing any negative impacts to these drainage areas.



Discharge Point			
Maintenance Component	Defect or Problem	Conditions When Maintenance Is Needed	Minimum Maintenance Required
Monitoring	Contaminants and Pollution	Any evidence of oil, gasoline, sewage, contaminants, or other pollutants	Identify and remove source. The effluent discharge should be clear and free of odor. Notify City at (360) 817-1567.
	Ditch or Stream Banks Eroding	Erosion, scouring, or head cuts in ditch or stream banks downstream of facility discharge point due to flow channelization or higher flows.	Stabilize ditch or stream banks. Report to City for engineer evaluation.
General	Missing or Moved Rock	Only one layer of rock exists above native soil in an area five square feet or larger, or any exposure of native soil	Replace or repair rock pad to design standards
	Erosion	Soil erosion in or adjacent to rock pad	Replace or repair rock pad to design standards
	Sediment	Sediment blocking 20% of the pipe diameter	Remove sediment
	Obstructions	Roots or debris enters pipe or deforms pipe, reducing flow	Remove roots from pipe by mechanical methods; do not use root-dissolving chemicals in storm sewer pipes. If necessary, remove vegetation over the line.
	Pipe Rusted or Deteriorated	Any part of the piping that is crushed or deformed excessively or any other failure to the piping	Repair or replace pipe
Energy Dissipater	See Energy Dissipater		

Oil/Water Separators

An oil/water separator is an underground vault that treats stormwater by mechanically separating oil from water. The oil rises to the surface and floats on the water and sediment settles to the bottom. Oil/water separators are typically utilized in locations where high oil concentrations in the stormwater runoff are anticipated (e.g., service and fuel stations). Oil/water separators are most commonly used as the first pretreatment facility in a series of stormwater management facilities.

These facilities have special problems for maintenance and should be serviced by contractors. The main issues are working in confined spaces and properly handling any sludge and oil cleaned from vaults or oil/water separators. Manufacturer's recommendations for maintenance should be followed at a minimum.

See SWMMWW [Appendix V-A](#), Table V-A.16 for baffle oil/water separator maintenance standards and Table V-A.17 for coalescing plate oil/water separator maintenance standards.

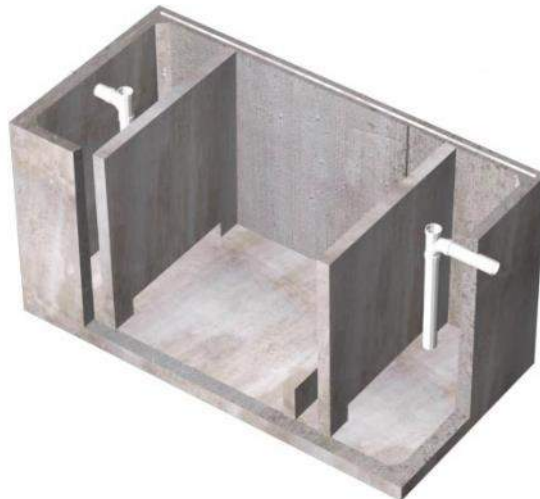

Baffle Oil/Water Separator



Coalescing Plate Oil/Water Separator

Flow Control Structures/Flow Restrictors

Flow control structures and flow restrictors direct or restrict flow in or out of facility components. Outflow controls on detention facilities are a common example where flow control structures slowly release stormwater at a specific rate. The flow is regulated by a combination of orifices (holes with specifically sized diameters) and weirs (plates with rectangular or 'V' shaped notch). Lack of maintenance of the control structure can result in the plugging of an orifice. If these flow controls are damaged, plugged, bypassed, or not working properly, the facility could overtop or release water too quickly.

See SWMMWW [Appendix V-A](#), Table V-A.4 for control structure/flow restrictor maintenance standards.

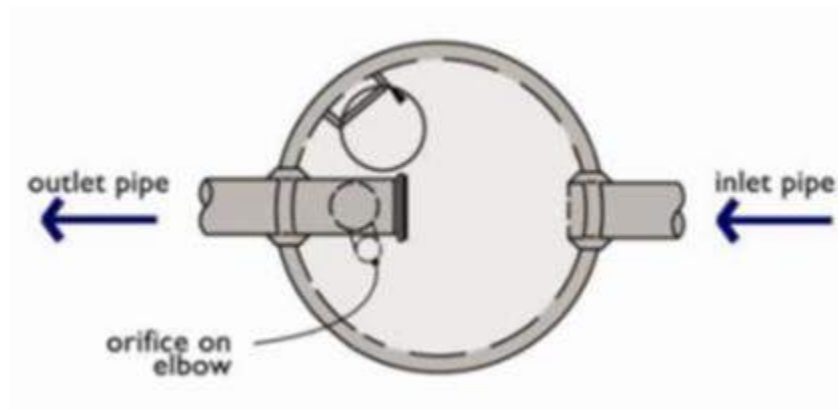

Plan View

Storm Sewer Pipe

Storm sewer pipes convey stormwater. Storm pipes are constructed of many different types of materials and are sometimes perforated to allow groundwater to be collected by the storm system. Storm pipes are cleaned to remove sediment or blockages when problems are identified. Storm pipes must be clear of obstructions and breaks to prevent localized flooding.



Storm Sewer Pipe			
Maintenance Component	Defect or Problem	Conditions When Maintenance Is Needed	Minimum Maintenance Required
General	Obstructions, Including Roots	Obstruction exists in pipe, reducing flow capacity	Remove obstruction. Use mechanical methods. Do not put root-dissolving chemicals in storm sewer pipes. If necessary, remove the vegetation over the line.
	Pipe Dented or Broken	Inlet/outlet pipe damaged or broken	Repair or replace pipe
	Pipe rusted or deteriorated	Any part of the piping that is crushed or deformed excessively or any other failure to the piping	Repair or replace pipe
	Sediment and Debris	Sediment or debris depth is greater than 15% of the pipe diameter	Clean pipe. Evaluate source of sediment upstream of the pipe and stabilize if possible.
	Broken Trash Screen	Trash screen is broken or missing parts	Repair or replace trash screen
	Contaminants and Pollution	Any evidence of oil, gasoline, contaminants, or other pollutants	Identify and remove source. Notify City at (360) 817-1567.

Closed Detention System

A closed detention system functions similarly to a detention pond but with the storage volume provided by an underground structure. The structure is typically constructed of large diameter pipe, plastic chamber structure or a concrete vault. These systems are typically utilized for sites that do not have space available for an above-ground system and are more commonly associated with commercial sites.

Underground detention systems are enclosed spaces where harmful chemicals and vapors can accumulate. Therefore, the maintenance of these facilities should be conducted by an individual trained and certified to work in hazardous confined spaces.

See SWMMWW [Appendix V-A](#), Table V-A.3 for closed detention maintenance standards.



Drywell

Drywells are perforated, open-bottomed manholes used to infiltrate stormwater into the ground. While not the intended use, drywells trap sediment and some of the oil pollutants in stormwater runoff. Drywells are more likely to fill with oily sediment in areas that lack swales or other treatment facilities. Fine oil sediment can clog drywells and lead to localized street flooding. Also, pollutants discharged into drywells can migrate into groundwater. Drywells were often installed in closed topographic depressions, areas with will-drained soils, or areas having inadequate storm sewers. Often, drywells contain groundwater.



Drywell			
Maintenance Component	Defect or Problem	Conditions When Maintenance Is Needed	Minimum Maintenance Required
General	Does not Dissipate Stormwater	Does not dissipate stormwater	Replace or repair
	Opening Clogged	Openings are clogged, reducing capacity	Clear openings or convert existing drywell to a sediment trap and install a new drywell or drainage trench. To convert to a sediment trap: grout holes, cover base with concrete, and add piping. Alterations to any storm facility cannot be done without approval from the City of Camas.
	Standing Water	Standing water indicates the drywell is into the groundwater table	Rebuild drywell to prevent stormwater from going directly into groundwater
	Trash and Debris	Trash or debris blocking any inlet or outlet pipe	Remove trash and debris
	Sediment	Sediment in drywell exceeds 60 percent of the depth below the lowest pipe	Remove sediment
	Structure Damage	Structure unsound	Replace or repair drywell to design standards.
	Contaminants and Pollution	Any evidence of oil, gasoline, contaminants, or other pollutants	Identify and remove source. Notify City at (360) 817-1567.
Cover	Cover Not in Place	Cover is missing or only partially in place.	Replace missing cover
	Cover Difficult to Remove	One maintenance person cannot remove cover after applying normal lifting pressure.	Make adjustments so that one maintenance person can remove the drywell cover.

Pond Leveler System

The pond leveler system consists of an intake cage and outlet pipe. This system is used to bypass beaver dams. The pond leveler system creates a permanent leak through the beaver dam that the beavers cannot stop.



Pond Leveler			
Maintenance Component	Defect or Problem	Conditions When Maintenance Is Needed	Minimum Maintenance Required
Intake Cage	Debris and sediment	Debris and sediment build up around cage	Remove debris and sediment build up around cage. Recommended tools: potato rake and a narrow, stiff shop broom.
	Structure	Broken cage, resulting in holes larger than 6" diameter.	Repair hole with similar cage material, attach with hog rings.
	Obstruction to inflow pipe	Debris obstructing pipe flow inside intake cage	Remove obstruction
Outflow Pipe	Obstruction	Debris obstructing outflow	Remove obstruction

Dispersion Trench

Dispersion trench are grave-filled trenches, which serve to spread runoff over vegetated pervious areas. This BMP reduce peak flows, provide some infiltration, and water quality benefits.

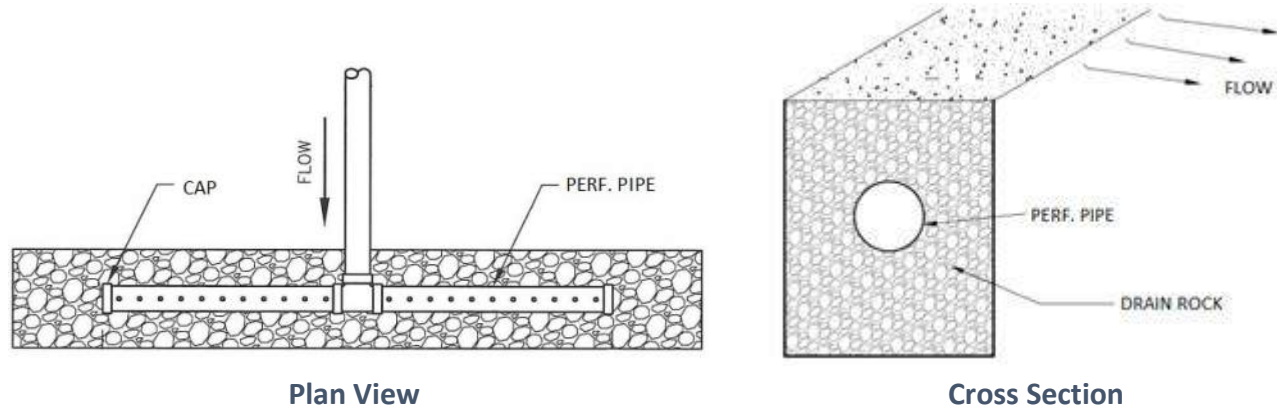

Plan View

Cross Section

Dispersion Trench			
Maintenance Component	Defect or Problem	Conditions When Maintenance Is Needed	Minimum Maintenance Required
General	Trash and Debris	Any trash and debris which exceed 1 cubic feet per 1,000 square feet. In general, there should be no visual evidence of dumping.	Remove trash and debris from site.
	Poisonous Vegetation and noxious weeds	Any poisonous or nuisance vegetation which may constitute a hazard to maintenance personnel or the public. Any evidence of noxious weeds as defined by State or local regulations.	Remove noxious weeds. Compliance with State or local eradication policies required. Apply requirements of adopted IPM policies for the use of herbicides.
	Contaminants and Pollution	Any evidence of oil, gasoline, contaminants, or other pollutants	Identify and remove source. Notify City at (360) 817-1567.
	Rodent Holes	Any evidence of rodent holes.	Fill holes.
Perforated Pipe	Sediment and/or obstruction	Sediment and/or obstruction impeding the flow, causing backup	Remove sediment and/or obstruction

Special Facilities

Manufactured Media Filter

Manufacture media filters are passive, flow-through, stormwater treatment systems. They are comprised of manholes or vaults that house media-filled filter cartridges. Stormwater passes through a filtering medium, which traps particulates and/or absorb pollutants such as dissolved metals and hydrocarbons. Once filtered through the media, the treated stormwater is directed to a collection pipe or discharge to a pond or open channel drainage way.

The filter media can be housed in cartridge filters enclosed in concrete vaults or catch basins. Structures will have vault doors or manhole lids for maintenance access. Various types of filter media are available from different manufactures. Determine the type of filter media used and consult manufacturer for maintenance recommendations.

See SWMMWW [Appendix V-A](#), Table V-A.15 for manufactured media filters maintenance standards.

Manufactured Media Filter – Additional Maintenance Standards			
Maintenance Component	Defect or Problem	Conditions When Maintenance Is Needed	Minimum Maintenance Required
Below Ground Vault or Manhole	Sediment Accumulation in Vault (no first chamber)	Sediment depth exceeds 4-inches on vault floor.	Remove sediment from vault floor. May require replacing media cartridges, consult manufacturer.



Permeable Pavement

Permeable pavement is a paving system which allows rainfall to percolate through the surface into the underlying soil or an aggregate bed, where stormwater is stored and infiltrated to underlying subgrade, or removed by an overflow drainage system.

See SWMMWW [Appendix V-A](#), Table V-A.22 for permeable pavement maintenance standards.



Modular Wetland

Modular wetlands linear is a biofiltration system that utilizes horizontal flow which allows for a smaller footprint, higher treatment capacity and design versatility. This system can be utilized downstream of storage for additional volume control and treatment. The modular wetland is contained in an underground vault that has different chambers containing media. Some modular wetlands can have plants growing out of it, but it is not required for the system to function. Once filtered through the media, the treated stormwater is directed to a collection pipe or discharge to a pond or open channel drainage way.



Modular Wetland			
Maintenance Component	Defect or Problem	Conditions When Maintenance Is Needed	Minimum Maintenance Required
General	Missing or damaged components	Missing or damaged internal components or cartridges	Replace missing or repair damaged internal components or cartridges
Inlet or Outlet	Obstruction	Obstruction to inlet or outlet that impedes flow	Remove obstruction
Pretreatment Chamber	Floatingables	Excessive accumulation of floatables, in which the length and width of the chamber is fully impacted more than 18"	Remove floatables
	Sediment	Excessive accumulation of sediment, more than 6" in depth	Remove sediment
Filter Cartridges	Sediment	Excessive accumulation of sediment on media, more than 85% clogged (blackish color)	Replace media
Vegetation (if applicable)	Overgrown	Overgrown vegetation	Trim/prune vegetation in accordance with landscaping and safety needs
Structure	Cracks in structure	Cracks wider than 1/2 inch or evidence of soil particles entering the structure through cracks	Repair cracks in vault

Tree Box Filter

Tree box filter is a stormwater treatment system incorporating high performance biofiltration media to remove pollutants from stormwater runoff.



Tree Box Filter			
Maintenance Component	Defect or Problem	Conditions When Maintenance Is Needed	Minimum Maintenance Required
Inlet	Excessive sediment or trash accumulation	Accumulated sediments or trash impair free flow of water into system	Remove sediment and/or trash
Mulch cover	Trash and debris	Excessive trash and/or debris accumulation	Remove trash and/or debris.
	Standing water	Ponding of water over mulch due to excessive fine sediment accumulation or spill of petroleum oils	Remove mulch and replace, contact manufacturer for advice
Vegetation	Plant not growing or in poor condition	Soil/mulch too wet, evidence of spill, incorrect plant selection, pest infestation, vandalism to plants	Plants should be healthy and pest free, contact manufacturer for advice
	Plant growth excessive	Plants should be appropriate to the species and location	Trim/prune plants in accordance with landscaping and safety needs
Structure	Cracks in structure	Cracks wider than 1/2 inch or evidence of soil particles entering the structure through cracks	Repair cracks in vault

Miscellaneous Items

Fences, Gates and Water Quality Signs

Fences are installed around the perimeter of stormwater facilities as a means of protecting the public, as they restrict entrance to the facility. Gates are installed to allow for maintenance access. Gates will be secured, typically with a double lock system (daisy chain) that allows access to the City and to the property owner's maintenance crew.

Water Quality Signs are installed on the fences, or on sign poles, within public view as a means of educating the public as to the presence of a stormwater facility. These signs also have a number located in the upper right hand corner that is cross referenced, at the City, to an address and maintenance responsibility. The publicly owned storm facility signs are green and the privately owned storm facility signs are white.

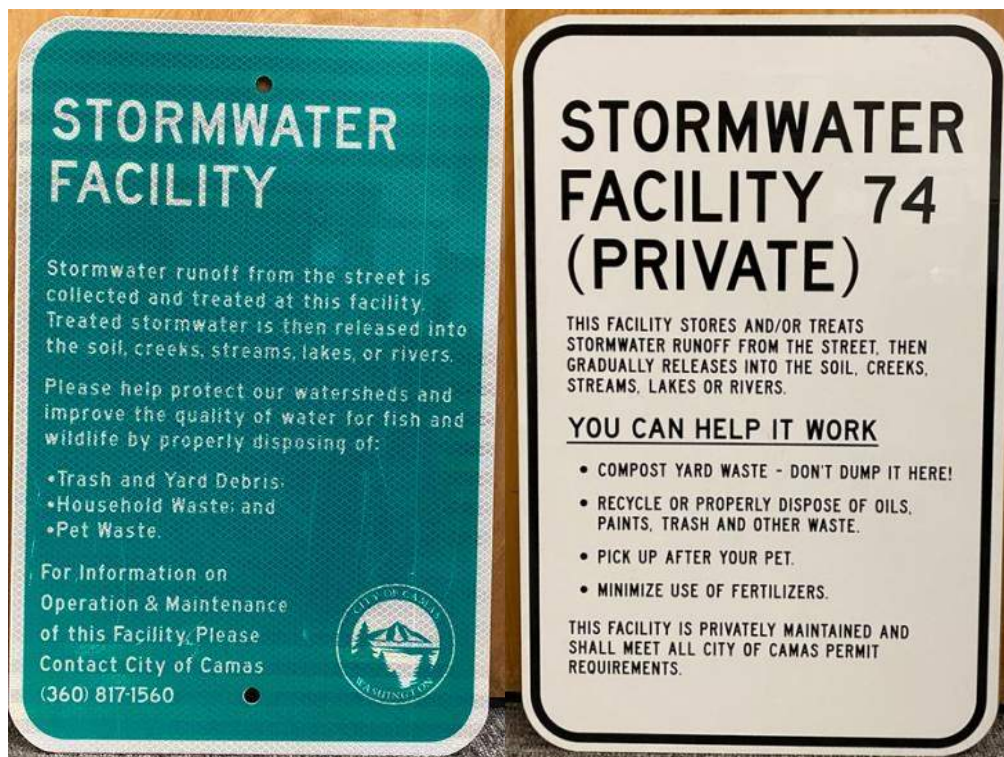

Public Storm Sign (Green)

Private Storm Sign (White)

2022 Stormwater Sewer System Operations & Maintenance Manual | City of Camas, Washington

Fence, Gate and Water Quality Sign			
Maintenance Component	Defect or Problem	Conditions When Maintenance Is Needed	Minimum Maintenance Required
General	Gate or Fence Allows Unauthorized Entry	Openings in fence, missing gate, openings beneath fence allowing unauthorized access	Repaired gate and/or fence to prevent unauthorized access
	Locking Mechanism	Mechanism cannot be opened by one maintenance person with proper tools	Repair/replace lock
		No lock on gate, allows unauthorized entry	Add lock
	Damaged Parts	Posts out of plumb more than six inches	Plumb post
		Top rails of plumb more than six inches	Repair top rails so that it is free of bends greater than 1 inch
	Erosion	Erosion has resulted in an opening under a fence that allows entry by people or pets	Replace soil under fence so that no opening exceeds 4 inches in height
	Sign	Sign is leaning more than 8 inches off vertical	Reset sign to plumb
		Sign is missing or 20% of surface is unreadable	Replace sign

Access Roads and Easements

Many stormwater facilities have access roads to bring in heavy equipment for facility maintenance. These roads are typically gravel and should be maintained for inspection access and ease of equipment entry. All facilities should allow access for the inspection process. The easement area should be adequately or otherwise stabilized. Bare soil areas will generate higher levels of stormwater runoff and increase erosion and sedimentation in stormwater facilities.

Access Road and Easements			
Maintenance Component	Defect or Problem	Conditions When Maintenance Is Needed	Minimum Maintenance Required
General	Erosion	Soils are bare or eroded	Seed or use other stabilization BMP
	Road Surface	Conditions of road surface may lead to erosion of the facility or limit access	Repair road
	Erosion of Ground Surface	Noticeable rills are seen in landscaped areas	Identify causes of erosion and implement BMPs to slow down/spread out the water. Fill, contour, and seed eroded areas. If needed, re-grade affected areas.
	Trash and Debris	Any trash and debris which exceed 1 cubic feet per 1,000 square feet. In general, there should be no visual evidence of dumping.	Remove trash and debris from site.
	Poisonous Vegetation and Noxious Weeds	Any poisonous or nuisance vegetation which may constitute a hazard to maintenance personnel or the public. Any evidence of noxious weeds as defined by State or local regulations.	Remove noxious weeds. Compliance with State or local eradication policies required. Apply requirements of adopted IPM policies for the use of herbicides.
	Tree Growth and Hazard Trees	Tree growth does not allow maintenance access or interferes with maintenance activity (i.e., slope mowing, silt removal, vactoring, or equipment movements). If dead, diseased, or dying trees are identified.	Remove hazardous tree that impede with maintenance access and activities. Remove trees that are damaging the pipe system and/or blocking drain inlet. Remove dead, diseased, or dying trees. Harvested trees should be recycled into mulch or other beneficial uses (e.g., alders for firewood).
	Weeds (Non-poisonous)	Weeds growing in more than 20% of the landscaped area (tree and shrubs only).	Remove weeds
	Insects	When insects such as wasps and hornets interfere with maintenance activities.	Destroy or remove insects from site. Apply insecticides in compliance with adopted IPM policies.

Pavement Sweeping

Pavement sweeping is performed as a means of removing sand, dirt, and litter from streets and curb gutters. Sweeping also reduces dust during dry weather. Pavement sweeping plays a large part in stormwater maintenance because it limits the amount of sediment washed into the municipal storm sewer system. The water quality procedure for street sweeping focuses on sediment removal and disposal. Reducing the amount of sediment washed into catch basins, curb inlets, detention facilities, drywells, and other facilities can save money because sweeping is generally cheaper than removing sediment from facilities. Sweeping also helps protect facilities from clogging with sediment.

Typically, the City sweeps the downtown area once a week and the whole city about three times per year. Most of the downtown area does not have water quality treatment. Pavement sweeping is the main source for pollution control.



Repair/Replacement Activities

Minor Culvert Repair (Not in a Stream)

This activity is for the replacement or repair of culverts and inlets. It applies only to structures that are in ditches that are specifically for storm drainage. These are ditches that do not carry water during dry weather. If there is any question about whether the ditch is a storm drain or a stream, consult with the Washington Department of Fish and Wildlife and the City of Camas Public Works Department.

Major Culvert Repair (at a Stream Crossing)

This activity is the replacement or repair of culverts and inlets bridging a stream or ditch with flowing water during dry weather. If there is any question about whether the ditch is a storm drain or a stream, consult the Washington Department of Fish and Wildlife and the City of Camas Public Works Department.

These projects must meet all regulatory requirements such as State Environmental Policy Act (SEPA), Shoreline Permit, Hydraulic Project Approval (HPA) and Flood Plain.



Vegetation Management

The City recognizes the special importance of the rivers, streams, wetlands, ponds, and stormwater control and treatment facilities. The sensitive nature of such habitat, their plant and animal communities, and their direct link with other waterways require that we establish specific policies to ensure their health. All landscape management decisions for controlling unwanted vegetation, diseases, and pests should follow the Integrated Pest Management (IPM) principles and decision-making rationale.

Integrated Pest Management (IPM) Principles

1. Correctly identify the pest problem and understand their life cycle. Refer to online resources such as [Washington State Noxious Weed Control Board](#) and [Washington Invasive Species Council](#).
2. Every landscape has a population of some pest insects, weeds, and diseases. Once the pest has been identified and studied, determine if low levels of the pest are tolerable. Small numbers of certain pests may not be harmful. If this is the case, simply continue to monitor the pest population.
3. If pest exceed tolerance thresholds, choose a safe and effective control method.
 - a. Cultural methods of vegetation and pest control are preferred and are first employed. Cultural control changes the pest's environment: landscape fabric, mulch, soil amendments, altering the irrigation method of duration, crop rotation, crop covers, etc.
 - b. Mechanical means of vegetation and pest control are next in line of preference and are utilized where feasible. Mechanical means consist of digging, hand-pulling, mowing, tilling, trapping, etc.
 - c. Biological methods of vegetation and pest control are considered before chemical means, where they are feasible. Biological control uses natural enemies: beneficial insects, managed grazing, bird boxes and perches, etc.
 - d. Chemical methods are used only when no other feasible methods exist. Chemical control is the use of pesticides to remove vegetation and pests.
4. Observe and record the results of the control treatment. Evaluate the effectiveness. If necessary, modify maintenance practices to support a healthy landscape and prevent recurrence of the pest.

A licensed pesticide applicator is required for performing any chemical application in stormwater facilities.

Applicators must be licensed in Washington State with an aquatic endorsement ([WAC 16-228-1545](#)).

Applicator must submit a copy of their license to the City prior to starting work. Aquatic pesticide products are recommended. No chemical application shall be applied directly in the water. Do not apply pesticide when it is raining. Check the weather and ensure there are multiple dry days before and after application. Do not apply pesticide on windy days to prevent drift movement of pesticide from target areas.

For vegetated areas outside of stormwater facilities, Washington State pesticide application laws and rules are followed, [Chapter 17.21 RCW](#) and [Chapter 16-228 WAC](#).

Plants and Groundcover

Use plants that will thrive in the growing conditions of each facility. Growing conditions are affected by moisture, soil conditions, and light. Plants native to western Washington are preferred. Recommended plants, seed mixes and groundcover list for biofiltration swales, bioretention systems, rain gardens, and other facility types are given in the respective BMP maintenance sections. It is best to reference the stormwater facility record drawings for vegetation replacements, if available. Fertilization of vegetated stormwater facilities should be avoided.

The City has adopted a list of approved plants for use in development projects, and to assist homeowners in choosing appropriate plantings. The list also has prohibited undesirable plants. Only plants approved for use on the [City of Camas Plant Materials](#) are allowed within the City's right-of-way.

Mulches and other ground coverings are useful during the installation and restoration of landscapes as well as their ongoing maintenance. Mulches meet a variety of needs. They suppress weeds, help to retain moisture around plants, reduce possible erosion and provide visual enhancement. Possible risk impacts to consider when using mulch are inadvertent introduction of non-native plants or migration of mulch material into waterways.

Possible scenarios where trees should be removed and/or trimmed in a stormwater facility (always check if the stormwater facility has a liner before tree removal):

- Trees that pose a risk to a stormwater structure due to root growth should be removed.
- Trees that are growing on spillways that would impede drainage should be removed.
- Hazardous trees should be removed.
- Trees/shrubs that hinder accessibility to access roads should be trimmed or removed.

References

Clark County. (July 2021). *Clark County Stormwater Manual 2015 Book 4 Stormwater Facility Operation and Maintenance*. <https://clark.wa.gov/sites/default/files/media/document/2021-11/CCSM%20Book%204%20Maintenance%20and%20Operations.pdf>

City of Battle Ground. (March 2019). *Stormwater Facility Maintenance Manual BG02.02*. <https://www.cityofbg.org/DocumentCenter/View/2100/2019-Stormwater-Facility-Maintenance-Manual-Final?bidId=>

Hinman, Curtis and Wulkan, Bruce. (December 2012). *Low Impact Development Technical Guidance Manual for Puget Sound*. <https://fortress.wa.gov/ecy/ezshare/wq/Permits/Flare/2019SWMMWW/Content/Resources/DocsForDownload/References/HinmanAndWulkan2012.pdf>

Hinman, Curtis. (June 2013). *Rain Garden Handbook for Western Washington: A Guide for Design, Installation, and Maintenance*. <https://apps.ecology.wa.gov/publications/publications/1310027.pdf>

Washington Department of Ecology. (July 2019). *Stormwater Management Manual for Western Washington*. https://fortress.wa.gov/ecy/ezshare/wq/Permits/Flare/2019SWMMWW/2019SWMMWW.htm#Topics/FrontCover.htm?TocPath=2019%2520SWMMWW%257C_____0

Washington State. *Noxious Weed Control Board*. <https://www.nwcb.wa.gov/>

Washington State Legislature. (1974). *Revised Code of Washington (RCW)*. <https://apps.leg.wa.gov/RCW/default.aspx>

Washington State Legislature. (2004). *Washington Administrative Code (WAC)*. <https://app.leg.wa.gov/WAC/default.aspx>

Washington State Recreation and Conservation Office. *Washington Invasive Species Council*. <https://invasivespecies.wa.gov/>

SEPARATOR SHEET

APPENDIX E

Stormwater Pollution Prevention Plan

Stormwater Pollution Prevention Plan

For

NE 13th Street Site Plan

Prepared For

Taz Kahn
3993 NW Currawong Court
Camas, WA 98607

Owner

Taz Kahn
3993 NW Currawong Court
Camas, WA 98607

Developer

Same as Owner

Operator/Contractor

Unknown

Project Site Location

20101 NE 13th Street
Camas, WA 98607
Parcel #176148-000

SWPPP Prepared By

PLS Engineering, Inc.
604 W Evergreen Blvd
Vancouver, WA 98660
(360) 944-6519

SWPPP Preparation Date

August 2023

Approximate Project Construction Dates

March 2024

Contents

1.0 Introduction.....	5
2.0 Site Description	7
2.1 Existing Conditions	7
2.2 Proposed Construction Activities.....	7
3.0 Construction Stormwater BMPs.....	9
3.1 The 13 BMP Elements.....	9
3.1.1 Element #1 – Mark Clearing Limits	9
3.1.2 Element #2 – Establish Construction Access	9
3.1.3 Element #3 – Control Flow Rates.....	10
3.1.4 Element #4 – Install Sediment Controls	10
3.1.5 Element #5 – Stabilize Soils.....	11
3.1.6 Element #6 – Protect Slopes.....	12
3.1.7 Element #7 – Protect Drain Inlets.....	12
3.1.8 Element #8 – Stabilize Channels and Outlets.....	13
3.1.9 Element #9 – Control Pollutants.....	13
3.1.10 Element #10 – Control Dewatering.....	15
3.2 Site Specific BMPs.....	15
3.3 Additional Advanced BMPs.....	15
4.0 Construction Phasing and BMP Implementation	17
5.0 Pollution Prevention Team	19
5.1 Roles and Responsibilities.....	19
5.2 Team Members.....	19
6.0 Site Inspections and Monitoring.....	21
6.1 Site Inspection	21
6.1.1 Site Inspection Frequency	21
6.1.2 Site Inspection Documentation.....	21
6.2 Stormwater Quality Monitoring	22
6.2.1 Turbidity Sampling.....	22
7.0 Reporting and Recordkeeping	25
7.1 Recordkeeping.....	25
7.1.1 Site Log Book.....	25
7.1.2 Records Retention.....	25
7.1.3 Access to Plans and Records	25
7.1.4 Updating the SWPPP.....	25
7.2 Reporting.....	26
7.2.1 Discharge Monitoring Reports	26

7.2.2 Notification of Noncompliance	26
Appendix A – Site Plans.....	27
Appendix B – Construction BMPs	29
Appendix C – Alternative BMPs.....	31
Appendix D – General Permit	33
Appendix E – Site Inspection Forms (and Site Log).....	35
Appendix F – Engineering Calculations.....	44

Appendix A Site plans

- Vicinity map (with all discharge points)
- Site plan with TESC measures

Appendix B Construction BMPs

- Possibly reference in BMPs, but likely it will be a consolidated list so that the applicant can photocopy from the list from the SWMMWW.

Appendix C Alternative Construction BMP list

- List of BMPs not selected, but can be referenced if needed in each of the 12 elements

Appendix D General Permit

Appendix E Site Log and Inspection Forms

Appendix F Engineering Calculations

1.0 Introduction

This Stormwater Pollution Prevention Plan (SWPPP) has been prepared for the Monte Verde construction project in Camas, Washington. The site is located on Parcel 173184000. Current address for the site is 22205 NE 28th Street, Camas, WA 98607 and the existing site is approximately 8.61 acres. Current proposed development associated with this SWPPP includes the construction of 34 single family lots along with the associated infrastructure. The stormwater plan associated with this project provides for stormwater management of all runoff from the site using two private infiltration trenches, and one stormwater detention facility. Stormwater runoff from the pollution generating surfaces will be treated by a ConTech media cartridge before being infiltrated.

Construction activities will include excavation, grading, construction of paving and sidewalk to serve the site, construction of an infiltration trench to mitigate for impacts to stormwater runoff from the new paving, and installation of utilities to serve the site including sanitary sewer, storm sewer, potable water, electrical, phone, and cable TV. The purpose of this SWPPP is to describe the proposed construction activities and all temporary and permanent erosion and sediment control (TESC) measures, pollution prevention measures, inspection/monitoring activities, and recordkeeping that will be implemented during the proposed construction project. The objectives of the SWPPP are to:

1. Implement Best Management Practices (BMPs) to prevent erosion and sedimentation, and to identify, reduce, eliminate or prevent stormwater contamination and water pollution from construction activity.
2. Prevent violations of surface water quality, ground water quality, or sediment management standards.
3. Prevent, during the construction phase, adverse water quality impacts including impacts on beneficial uses of the receiving water by controlling peak flow rates and volumes of stormwater runoff at the Permittee's outfalls and downstream of the outfalls.

This SWPPP was prepared using the Ecology SWPPP Template downloaded from the Ecology website. This SWPPP was prepared based on the requirements set forth in the Construction Stormwater General Permit and the *Stormwater Management Manual for Western Washington* (SWMMWW). The report is divided into seven main sections with several appendices that include stormwater related reference materials. The topics presented in the each of the main sections are:

- Section 1 – INTRODUCTION. This section provides a summary description of the project, and the organization of the SWPPP document.

Stormwater Pollution Prevention Plan

- Section 2 – SITE DESCRIPTION. This section provides a detailed description of the existing site conditions, proposed construction activities, and calculated stormwater flow rates for existing conditions and post-construction conditions.
- Section 3 – CONSTRUCTION BMPs. This section provides a detailed description of the BMPs to be implemented based on the 12 required elements of the SWPPP (SWMMEW 2004).
- Section 4 – CONSTRUCTION PHASING AND BMP IMPLEMENTATION. This section provides a description of the timing of the BMP implementation in relation to the project schedule.
- Section 5 – POLLUTION PREVENTION TEAM. This section identifies the appropriate contact names (emergency and non-emergency), monitoring personnel, and the onsite temporary erosion and sedimentation control inspector
- Section 6 – INSPECTION AND MONITORING. This section provides a description of the inspection and monitoring requirements such as the parameters of concern to be monitored, sample locations, sample frequencies, and sampling methods for all stormwater discharge locations from the site.
- Section 7 – RECORDKEEPING. This section describes the requirements for documentation of the BMP implementation, site inspections, monitoring results, and changes to the implementation of certain BMPs due to site factors experienced during construction.

Supporting documentation and standard forms are provided in the following Appendices:

- Appendix A – Site plans
- Appendix B – Construction BMPs
- Appendix C – Alternative Construction BMP list
- Appendix D – General Permit
- Appendix E – Site Log and Inspection Forms
- Appendix F – Engineering Calculations

2.0 Site Description

2.1 Existing Conditions

Current Addresses for the site is 20101 NE 13th Street, Camas, WA 98607. The site is approximately 0.97 acres. The property's topography is moderately sloped from a high point at the NW corner of the site to low areas along at the South boundary of the site. The site has an existing house will be removed. The remaining area consists of grass, and trees, and landscaping.

The soils are mapped by the NRCS as Wind River gravelly loam (WrB) for the majority of the site, and Cove silty clay loam (CwA) at the SW corner and Eastern edge of the site.

2.2 Proposed Construction Activities

The project proposes to develop a gas station with a mini-mart and car wash on a single lot. Construction activities will include excavation, grading, construction of paving and sidewalk to serve the site, construction of stormwater facilities to mitigate for impacts to stormwater runoff from the new paving, and installation of utilities to serve the site including sanitary sewer, storm sewer, potable water, electrical, phone, and cable TV.

Temporary erosion and sediment control facilities will be installed prior to site construction to handle construction-phase stormwater runoff. The schedule and phasing of BMPs during construction is provided in Section 4.0.

Stormwater runoff has been calculated using Western Washington Hydrology Model (WWHM). The stormwater facilities were designed to treat and detain the runoff generated by the site prior to discharge.

After the site has been graded and all new utilities are installed, the building construction will commence. Trees will also be planted in the landscape areas noted in the Landscape Plan. Temporary seeding will occur over the lots to establish vegetative cover until such time as individual buildings are developed and permanent landscaping occurs.

3.0 Construction Stormwater BMPs

3.1 The 13 BMP Elements

3.1.1 Element #1 – Mark Clearing Limits

To protect adjacent properties and to reduce the area of soil exposed to construction, the limits of construction will be clearly marked before land-disturbing activities begin. Trees that are to be preserved, as well as all sensitive areas and their buffers, shall be clearly delineated, both in the field and on the plans. In general, natural vegetation and native topsoil shall be retained in an undisturbed state to the maximum extent possible. The BMPs relevant to marking the clearing limits that will be applied for this project include:

- Preserving Native Vegetation (BMP C101)
- Silt Fence (BMP C233)

Alternate BMPs for marking clearing limits are included in Appendix C as a quick reference tool for the onsite inspector in the event the BMP(s) listed above are deemed ineffective or inappropriate during construction to satisfy the requirements set forth in the General NPDES Permit (Appendix D). To avoid potential erosion and sediment control issues that may cause a violation(s) of the NPDES Construction Stormwater permit (as provided in Appendix D), the Certified Erosion and Sediment Control Lead will promptly initiate the implementation of one or more of the alternative BMPs listed in Appendix C after the first sign that existing BMPs are ineffective or failing.

3.1.2 Element #2 – Establish Construction Access

Construction access or activities occurring on unpaved areas shall be minimized, yet where necessary, access points shall be stabilized to minimize the tracking of sediment onto public roads, and wheel washing, street sweeping, and street cleaning shall be employed to prevent sediment from entering state waters. All wash wastewater shall be controlled on site. The specific BMPs related to establishing construction access that will be used on this project include:

- Stabilized Construction Entrance (BMP C105)

Alternate construction access BMPs are included in Appendix C as a quick reference tool for the onsite inspector in the event the BMP(s) listed above are deemed ineffective or inappropriate during construction to satisfy the requirements set forth in the General NPDES Permit (Appendix D). To avoid potential erosion and sediment control issues that may cause a violation(s) of the NPDES Construction Stormwater permit (as provided in Appendix D), the Certified Erosion and Sediment Control Lead will promptly initiate the implementation of one or more of the alternative BMPs listed in Appendix C after the first sign that existing BMPs are ineffective or failing.

3.1.3 Element #3 – Control Flow Rates

In order to protect the properties and waterways downstream of the project site, stormwater discharges from the site will be controlled. The specific BMPs for flow control that shall be used on this project include:

- Downspout Full Infiltration - Infiltration Trenches (BMP T5.10B).
- Infiltration Trenches (BMP R5.11).

Alternate flow control BMPs are included in Appendix C as a quick reference tool for the onsite inspector in the event the BMP(s) listed above are deemed ineffective or inappropriate during construction to satisfy the requirements set forth in the General NPDES Permit (Appendix D). To avoid potential erosion and sediment control issues that may cause a violation(s) of the NPDES Construction Stormwater permit (as provided in Appendix D), the Certified Erosion and Sediment Control Lead will promptly initiate the implementation of one or more of the alternative BMPs listed in Appendix C after the first sign that existing BMPs are ineffective or failing.

The project site is located west of the Cascade Mountain Crest. As such, the project must comply with Minimum Requirement 7 (Ecology 2005).

In general, discharge rates of stormwater from the site will be controlled where increases in impervious area or soil compaction during construction could lead to downstream erosion, or where necessary to meet local agency stormwater discharge requirements (e.g. discharge to combined sewer systems).

3.1.4 Element #4 – Install Sediment Controls

All stormwater runoff from disturbed areas shall pass through an appropriate sediment removal BMP before leaving the construction site or prior to being discharged to an infiltration facility. The specific BMPs to be used for controlling sediment on this project include:

- Silt Fence (BMP C233)
- Storm Drain Inlet Protection (BMP C220)

Silt fencing and storm drain inlet protection will be adequate for sediment control during summer months. Alternate sediment control BMPs are included in Appendix C as a quick reference tool for the onsite inspector in the event the BMP(s) listed above are deemed ineffective or inappropriate during construction to satisfy the requirements set forth in the General NPDES Permit (Appendix D). To avoid potential erosion and sediment control issues that may cause a violation(s) of the NPDES Construction Stormwater permit (as provided in Appendix D), the Certified Erosion and Sediment Control Lead will promptly initiate the implementation of one or more of the alternative BMPs listed in Appendix C after the first sign that existing BMPs are ineffective or failing.

In addition, sediment will be removed from paved areas in and adjacent to construction work areas manually or using mechanical sweepers, as needed, to minimize tracking of sediments on vehicle tires away from the site and to minimize washoff of sediments from adjacent streets in runoff.

Whenever possible, sediment laden water shall be discharged into onsite, relatively level, vegetated areas (BMP C240 paragraph 5, page 4-102).

In some cases, sediment discharge in concentrated runoff can be controlled using permanent stormwater BMPs (e.g., infiltration swales, ponds, trenches). Sediment loads can limit the effectiveness of some permanent stormwater BMPs, such as those used for infiltration or biofiltration; however, those BMPs designed to remove solids by settling (wet ponds or detention ponds) can be used during the construction phase. When permanent stormwater BMPs will be used to control sediment discharge during construction, the structure will be protected from excessive sedimentation with adequate erosion and sediment control BMPs. Any accumulated sediment shall be removed after construction is complete and the permanent stormwater BMP will be restabilized with vegetation per applicable design requirements once the remainder of the site has been stabilized.

The following BMPs will be implemented as end-of-pipe sediment controls as required to meet permitted turbidity limits in the site discharge(s). Prior to the implementation of these technologies, sediment sources and erosion control and soil stabilization BMP efforts will be maximized to reduce the need for end-of-pipe sedimentation controls.

- Construction Stormwater Filtration (BMP C251)
- Construction Stormwater Chemical Treatment (BMP C 250)
(implemented only with prior written approval from Ecology).

3.1.5 Element #5 – Stabilize Soils

Exposed and unworked soils shall be stabilized with the application of effective BMPs to prevent erosion throughout the life of the project. The specific BMPs for soil stabilization that shall be used on this project include:

- Temporary and Permanent Seeding (BMP C120)
- Mulching (BMP C121)
- Nets and Blankets (BMP C122)
- Plastic Covering (BMP C123)
- Topsoiling (BMP C125)
- Surface Roughening (BMP C130)
- Dust Control (BMP C140)
- Early application of gravel base on areas to be paved

Alternate soil stabilization BMPs are included in Appendix C as a quick reference tool for the onsite inspector in the event the BMP(s) listed above are deemed ineffective or inappropriate during construction to satisfy the requirements set forth in the General NPDES Permit (Appendix D). To avoid potential erosion and sediment control issues that may cause a violation(s) of the NPDES Construction Stormwater permit (as provided in Appendix D), the Certified Erosion and Sediment Control Lead will promptly initiate the implementation of one or more of the alternative BMPs listed in Appendix C after the first sign that existing BMPs are ineffective or failing.

The project site is located west of the Cascade Mountain Crest. As such, no soils shall remain exposed and unworked for more than 7 days during the dry season (May 1 to September 30) and 2 days during the wet season (October 1 to April 30). Regardless of the time of year, all soils shall be stabilized at the end of the shift before a holiday or weekend if needed based on weather forecasts.

In general, cut and fill slopes will be stabilized as soon as possible and soil stockpiles will be temporarily covered with plastic sheeting. All stockpiled soils shall be stabilized from erosion, protected with sediment trapping measures, and where possible, be located away from storm drain inlets, waterways, and drainage channels.

3.1.6 Element #6 – Protect Slopes

All cut and fill slopes will be designed, constructed, and protected in a manner that minimizes erosion. The following specific BMPs will be used to protect slopes for this project:

- Temporary and Permanent Seeding (BMP C120)

Alternate slope protection BMPs are included in Appendix C as a quick reference tool for the onsite inspector in the event the BMP(s) listed above are deemed ineffective or inappropriate during construction to satisfy the requirements set forth in the General NPDES Permit (Appendix D). To avoid potential erosion and sediment control issues that may cause a violation(s) of the NPDES Construction Stormwater permit (as provided in Appendix D), the Certified Erosion and Sediment Control Lead will promptly initiate the implementation of one or more of the alternative BMPs listed in Appendix C after the first sign that existing BMPs are ineffective or failing.

3.1.7 Element #7 – Protect Drain Inlets

All storm drain inlets and culverts made operable during construction or inlets near the site that could potentially receive surface runoff from the construction site shall be protected to prevent unfiltered or untreated water from entering the drainage conveyance system. However, the first priority is to keep all access roads clean of sediment and keep street wash water separate from entering storm drains until treatment can be provided. Storm Drain Inlet Protection (BMP C220) will be implemented for all drainage inlets and culverts that could potentially be impacted by sediment-laden runoff on and near the project site. The following inlet protection measures will be applied on this project:

Drop Inlet Protection

- Block and Gravel Drop Inlet Protection
- Gravel and Wire Drop Inlet Protection
- Catch Basin Filter

If the BMP options listed above are deemed ineffective or inappropriate during construction to satisfy the requirements set forth in the General NPDES Permit (Appendix D), or if no BMPs are listed above but deemed necessary during construction, the Certified Erosion and Sediment Control Lead shall implement one or more of the alternative BMP inlet protection options listed in Appendix C.

3.1.8 Element #8 – Stabilize Channels and Outlets

Where site runoff is to be conveyed in channels or discharged to a stream or some other natural drainage point, efforts will be taken to prevent downstream erosion. The specific BMPs for channel and outlet stabilization that shall be used on this project include:

- Outlet Protection (BMP C209)

Alternate channel and outlet stabilization BMPs are included in Appendix C as a quick reference tool for the onsite inspector in the event the BMP(s) listed above are deemed ineffective or inappropriate during construction to satisfy the requirements set forth in the General NPDES Permit (Appendix D). To avoid potential erosion and sediment control issues that may cause a violation(s) of the NPDES Construction Stormwater permit (as provided in Appendix D), the Certified Erosion and Sediment Control Lead will promptly initiate the implementation of one or more of the alternative BMPs listed in Appendix C after the first sign that existing BMPs are ineffective or failing.

The project site is located west of the Cascade Mountain Crest. As such, all temporary on-site conveyance channels shall be designed, constructed, and stabilized to prevent erosion from the expected peak 10-minute velocity of flow from a Type 1A, 10-year, 24-hour recurrence interval storm for the developed condition. Alternatively, the 10-year, 1-hour peak flow rate indicated by an approved continuous runoff simulation model, increased by a factor of 1.6, shall be used. Stabilization, including armoring material, adequate to prevent erosion of outlets, adjacent streambanks, slopes, and downstream reaches shall be provided at the outlets of all conveyance systems.

3.1.9 Element #9 – Control Pollutants

All pollutants, including waste materials and demolition debris, that occur onsite shall be handled and disposed of in a manner that does not cause contamination of stormwater. Good housekeeping and preventative measures will be taken to ensure that the site will be kept clean, well organized, and free of debris. If required, BMPs to be implemented to control specific sources of pollutants are discussed below.

Vehicles, construction equipment, and/or petroleum product storage/dispensing:

- All vehicles, equipment, and petroleum product storage/dispensing areas will be inspected regularly to detect any leaks or spills, and to identify maintenance needs to prevent leaks or spills.
- On-site fueling tanks and petroleum product storage containers shall include secondary containment.
- Spill prevention measures, such as drip pans, will be used when conducting maintenance and repair of vehicles or equipment.
- In order to perform emergency repairs on site, temporary plastic will be placed beneath and, if raining, over the vehicle.
- Contaminated surfaces shall be cleaned immediately following any discharge or spill incident.

Stormwater Pollution Prevention Plan

Chemical storage:

- Any chemicals stored in the construction areas will conform to the appropriate source control BMPs listed in Volume IV of the Ecology stormwater manual. In Western WA, all chemicals shall have cover, containment, and protection provided on site, per BMPC153 for Material Delivery, Storage and Containment in SWMMWW 2005
- Application of agricultural chemicals, including fertilizers and pesticides, shall be conducted in a manner and at application rates that will not result in loss of chemical to stormwater runoff. Manufacturers' recommendations for application procedures and rates shall be followed.

Excavation and tunneling spoils dewatering waste:

- Dewatering BMPs and BMPs specific to the excavation and tunneling (including handling of contaminated soils) are discussed under Element 10.

Demolition:

- Dust released from demolished sidewalks, buildings, or structures will be controlled using Dust Control measures (BMP C140).
- Storm drain inlets vulnerable to stormwater discharge carrying dust, soil, or debris will be protected using Storm Drain Inlet Protection (BMP C220 as described above for Element 7).
- Process water and slurry resulting from sawcutting and surfacing operations will be prevented from entering the waters of the State by implementing Sawcutting and Surfacing Pollution Prevention measures (BMP C152).

Concrete and grout:

- Process water and slurry resulting from concrete work will be prevented from entering the waters of the State by implementing Concrete Handling measures (BMP C151).

Sanitary wastewater:

- Portable sanitation facilities will be firmly secured, regularly maintained, and emptied when necessary.
- Wheel wash or tire bath wastewater shall be discharged to a separate on-site treatment system or to the sanitary sewer as part of Wheel Wash implementation (BMP C106).

Solid Waste:

- Solid waste will be stored in secure, clearly marked containers.

Other:

- Other BMPs will be administered as necessary to address any additional pollutant sources on site.

The facility does not require a Spill Prevention, Control, and Countermeasure (SPCC) Plan under the Federal regulations of the Clean Water Act (CWA).

3.1.10 Element #10 – Control Dewatering

3.1.13 Element #13 – Protect Low Impact Development BMPs

- Protect all bioretention and rain garden BMP's from sedimentation through installation and maintenance of erosion control BMP's on portions of the site that drain into them. Restore the BMP's to their fully functioning condition if they accumulate sediment during construction. Restoring the BMP must include removal of sediment and any sediment-laden bioretention/ rain garden soils, and replacing the removed soils with soils meeting the design specification.
- Prevent compacting bioretention and rain garden BMP's by excluding construction equipment and foot traffic. Protect completed lawn and landscaped areas from compaction by construction equipment.
- Control erosion and avoid introducing sediment from surrounding land uses onto permeable pavements. Do not allow muddy construction equipment on the base material or pavement. Do not allow sediment-laden runoff into permeable pavements or base materials.
- Pavements fouled with sediments or no longer passing an initial infiltration test must be cleaned using procedures from Book 4 of the manufacturer's procedures.
- Keep all heavy equipment off existing soils under LID facilities that have been excavated to final grade to retain the infiltration rate of the soils

3.2 Site Specific BMPs

Site specific BMPs are shown on the TESC Plan Sheets and Details in Appendix A. These site-specific plan sheets will be updated annually.

3.3 Additional Advanced BMPs

- The following BMPs are advanced and are only recommended if construction activities are complex enough to warrant them; or if the site has the potential for significant impacts to water quality. The following BMPs are directed at “end-of-pipe” treatment for sedimentation issues related to turbid runoff from construction sites. Effective BMPs are most often the simple BMPs and focus on the minimization of erosion before sedimentation is an issue. The following BMPs will most likely be implemented only after other BMP options are exhausted, or if the construction activity is large and off-site sedimentation or turbid runoff occurs or is inevitable.
- For BMP 250, written pre-approval, through Ecology is required (see SWMMWW 2005):
- BMP C250: Construction Stormwater Chemical Treatment
- BMP C251: Construction Stormwater Filtration.

4.0 Construction Phasing and BMP Implementation

The BMP implementation schedule will be driven by the construction schedule. The following provides a sequential list of the proposed construction schedule milestones and the corresponding BMP implementation schedule. The list contains key milestones such as wet season construction.

The BMP implementation schedule listed below is keyed to proposed phases of the construction project and reflects differences in BMP installations and inspections that relate to wet season construction. The project site is located west of the Cascade Mountain Crest. As such, the dry season is considered to be from May 1 to September 30 and the wet season is considered to be from October 1 to April 30.

- | | |
|---|----------|
| • Estimate of Construction start date: | 3/01/24 |
| • Estimate of Construction finish date: | 9/30/27 |
| • Mobilize equipment on site: | 3/01/24 |
| • Mobilize and store all ESC and soil stabilization products: | 3/01/24 |
| • Install ESC measures: | 3/01/24 |
| • Install stabilized construction entrance: | 3/01/24 |
| • Begin clearing and grubbing: | 3/01/24 |
| • Demolish existing structures: | 3/01/24 |
| • Begin site grading | 3/01/24 |
| • Site grading ends | 3/30/24 |
| • Excavate and install new utilities and services: | 4/01/24 |
| • Excavation for building foundations | 3/06/24 |
| • Begin building construction: | 3/06/24 |
| • Complete utility construction | 3/06/24 |
| • Begin implementing soil stabilization and sediment control BMPs throughout the site in preparation for wet season: | 3/06/24 |
| • Wet Season starts: | 10/01/24 |
| • Site inspections and monitoring conducted weekly and for applicable rain events as detailed in Section 6 of this SWPPP: | 3/01/24 |
| • Implement Element #12 BMPs and manage site to minimize soil disturbance during the wet season: | 3/01/24 |
| • Complete road paving | 5/30/24 |
| • Building construction complete: | 9/06/25 |
| • Dry Season starts: | 5/01/24 |

5.0 Pollution Prevention Team

5.1 Roles and Responsibilities

The pollution prevention team consists of personnel responsible for implementation of the SWPPP, including the following:

- Certified Erosion and Sediment Control Lead (CESCL) – primary contractor contact, responsible for site inspections (BMPs, visual monitoring, sampling, etc.); to be called upon in case of failure of any ESC measures.
- Resident Engineer – For projects with engineered structures only (sediment ponds/traps, sand filters, etc.): site representative for the owner that is the project's supervising engineer responsible for inspections and issuing instructions and drawings to the contractor's site supervisor or representative
- Emergency Ecology Contact – individual to be contacted at Ecology in case of emergency.
- Emergency Owner Contact – individual that is the site owner or representative of the site owner to be contacted in the case of an emergency.
- Non-Emergency Ecology Contact – individual that is the site owner or representative of the site owner than can be contacted if required.
- Monitoring Personnel – personnel responsible for conducting water quality monitoring; for most sites this person is also the Certified Erosion and Sediment Control Lead.

5.2 Team Members

Names and contact information for those identified as members of the pollution prevention team are provided in the following table.

Title	Name(s)	Phone Number
Certified Erosion and Sediment Control Lead (CESCL)	Unknown	
Resident Engineer	Travis Johnson	(360)944-6519
Emergency Ecology Contact	Unknown	
Emergency Owner Contact	Unknown	
Non-Emergency Ecology Contact	Unknown	
Monitoring Personnel	Unknown	

6.0 Site Inspections and Monitoring

Monitoring includes visual inspection, monitoring for water quality parameters of concern, and documentation of the inspection and monitoring findings in a site log book. A site log book will be maintained for all on-site construction activities and will include:

- A record of the implementation of the SWPPP and other permit requirements;
- Site inspections; and,
- Stormwater quality monitoring.

For convenience, the inspection form and water quality monitoring forms included in this SWPPP include the required information for the site log book. This SWPPP may function as the site log book if desired, or the forms may be separated and included in a separate site log book. However, if separated, the site log book but must be maintained on-site or within reasonable access to the site and be made available upon request to Ecology or the local jurisdiction.

6.1 Site Inspection

All BMPs will be inspected, maintained, and repaired as needed to assure continued performance of their intended function. The inspector will be a Certified Erosion and Sediment Control Lead (CESCL) per BMP C160. The name and contact information for the CESCL is provided in Section 5 of this SWPPP.

Site inspection will occur in all areas disturbed by construction activities and at all stormwater discharge points. Stormwater will be examined for the presence of suspended sediment, turbidity, discoloration, and oily sheen. The site inspector will evaluate and document the effectiveness of the installed BMPs and determine if it is necessary to repair or replace any of the BMPs to improve the quality of stormwater discharges. All maintenance and repairs will be documented in the site log book or forms provided in this document. All new BMPs or design changes will be documented in the SWPPP as soon as possible.

6.1.1 Site Inspection Frequency

Site inspections will be conducted at least once a week and within 24 hours following any discharge from the site. For sites with temporary stabilization measures, the site inspection frequency can be reduced to once every month.

6.1.2 Site Inspection Documentation

The site inspector will record each site inspection using the site log inspection forms provided in Appendix E. The site inspection log forms may be separated from this SWPPP document, but will be maintained on-site or within reasonable access to the site and be made available upon request to Ecology or the local jurisdiction.

6.2 Stormwater Quality Monitoring

The construction site will comply with the requirements set forth in the 2015 Construction Stormwater General Permit (revised 2017) seen in Appendix D. A Certified Erosion and Sediment Control Lead shall be on-site or on-call at all times.

The following text describes the monitoring for the proposed development.

6.2.1 Turbidity Sampling

The receiving water body, Lacamas Creek Watershed, is impaired for turbidity. Mandatory BMPs (Best Management Practices) and erosion control practices put in place by the permit will appropriately minimize the turbidity of the stormwater discharge. Monitoring requirements for the proposed project will include weekly turbidity sampling to monitor site discharges for water quality compliance as required by the NPDES Construction Stormwater General Permit, provided that site discharges occur. It should be noted that the site is designed such that all site runoff will be infiltrated so it is likely that discharges will be rare or may not occur at all. Sampling will be conducted at all discharge points at least once per calendar week.

Turbidity sampling during construction will be completed weekly in order to confirm that erosion control measures are meeting the water quality standards for turbidity (Where an applicable TMDL has not specified a waste load allocation for construction stormwater discharge, but has not excluded these discharges, compliance with special Conditions S4 (monitoring) and S9 (SWPPPs) will constitute compliance with the approved TMDL (S8.E.1.c)). Special Conditions S4 establishes that the key benchmark values that require action are 25 NTU for turbidity (equivalent to 32 cm transparency) and 250 NTU for turbidity (equivalent to 6 cm transparency). If the 25 NTU benchmark for turbidity (equivalent to 32 cm transparency) is exceeded, the following steps will be conducted:

1. Ensure all BMPs specified in this SWPPP are installed and functioning as intended.
2. Assess whether additional BMPs should be implemented, and document revisions to the SWPPP as necessary.
3. Sample discharge location daily until the analysis results are less than 25 NTU (turbidity) or greater than 32 cm (transparency).

If the turbidity is greater than 25 NTU (or transparency is less than 32 cm) but less than 250 NTU (transparency greater than 6 cm) for more than 3 days, additional treatment BMPs will be implemented within 24 hours of the third consecutive sample that exceeded the benchmark value. Additional treatment BMPs to be considered will include, but are not limited to, off-site treatment, infiltration, filtration and chemical treatment.

If the 250 NTU benchmark for turbidity (or less than 6 cm transparency) is exceeded at any time, the following steps will be conducted:

1. Notify Ecology by phone within 24 hours of analysis (see Section 5.0 of this SWPPP for contact information).
2. Continue daily sampling until the turbidity is less than 25 NTU (or transparency is greater than 32 cm).

Stormwater Pollution Prevention Plan

3. Initiate additional treatment BMPs such as off-site treatment, infiltration, filtration and chemical treatment within 24 hours of the first 250 NTU exceedance.
4. Implement additional treatment BMPs as soon as possible, but within 7 days of the first 250 NTU exceedance.
5. Describe inspection results and remedial actions taken in the site log book and in monthly discharge monitoring reports as described in Section 7.0 of this SWPPP.

In the event that Turbidity results are greater than 25 NTUs, or the site is determined to be out of compliance with surface water quality standards for turbidity, the following BMPs should be established, re-established or implemented as determined necessary by the Certified Erosion and Sediment Control lead (CESCL) in order to bring the site back into compliance:

BMP C105: Stabilized Construction Entrance / Exit (repair construction entrance as necessary)

BMP C106: Wheel Wash (repair wheel wash as necessary)

BMP C120: Temporary and permanent Seeding

BMP C124: Sodding

BMP C140: Dust Control

BMP C209: Outlet Protection

BMP C220: Storm Drain Inlet Protection (add more inlet protection, as necessary)

BMP C233: Silt Fence (add more silt fencing as necessary)

7.0 Reporting and Recordkeeping

7.1 Recordkeeping

7.1.1 Site Log Book

A site log book will be maintained for all on-site construction activities and will include:

- A record of the implementation of the SWPPP and other permit requirements;
- Site inspections; and,
- Stormwater quality monitoring.

For convenience, the inspection form and water quality monitoring forms included in this SWPPP include the required information for the site log book.

7.1.2 Records Retention

Records of all monitoring information (site log book, inspection reports/checklists, etc.), this Stormwater Pollution Prevention Plan, and any other documentation of compliance with permit requirements will be retained during the life of the construction project and for a minimum of three years following the termination of permit coverage in accordance with permit condition S5.C.

7.1.3 Access to Plans and Records

The SWPPP, General Permit, Notice of Authorization letter, and Site Log Book will be retained on site or within reasonable access to the site and will be made immediately available upon request to Ecology or the local jurisdiction. A copy of this SWPPP will be provided to Ecology within 14 days of receipt of a written request for the SWPPP from Ecology. Any other information requested by Ecology will be submitted within a reasonable time. A copy of the SWPPP or access to the SWPPP will be provided to the public when requested in writing in accordance with permit condition S5.G.

7.1.4 Updating the SWPPP

In accordance with Conditions S3, S4.B, and S9.B.3 of the General Permit, this SWPPP will be modified if the SWPPP is ineffective in eliminating or significantly minimizing pollutants in stormwater discharges from the site or there has been a change in design, construction, operation, or maintenance at the site that has a significant effect on the discharge, or potential for discharge, of pollutants to the waters of the State. The SWPPP will be modified within seven days of determination based on inspection(s) that additional or modified BMPs are necessary to correct problems identified, and an updated timeline for BMP implementation will be prepared.

7.2 Reporting

7.2.1 Discharge Monitoring Reports

Discharge Monitoring Reports (DMRs) will be submitted to Ecology monthly. If there was no discharge during a given monitoring period, the Permittee shall submit the form as required, with the words “No discharge” entered in the place of monitoring results. The DMR due date is 15 days following the end of each month.

Water quality sampling results will be submitted to Ecology monthly on Discharge Monitoring Report (DMR) forms in accordance with permit condition S5.B. If there was no discharge during a given monitoring period, the form will be submitted with the words “no discharge” entered in place of the monitoring results. If a benchmark was exceeded, a brief summary of inspection results and remedial actions taken will be included. If sampling could not be performed during a monitoring period, a DMR will be submitted with an explanation of why sampling could not be performed.

7.2.2 Notification of Noncompliance

If any of the terms and conditions of the permit are not met, and it causes a threat to human health or the environment, the following steps will be taken in accordance with permit section S5.F:

1. Ecology will be immediately notified of the failure to comply.
2. Immediate action will be taken to control the noncompliance issue and to correct the problem. If applicable, sampling and analysis of any noncompliance will be repeated immediately and the results submitted to Ecology within five (5) days of becoming aware of the violation.
3. A detailed written report describing the noncompliance will be submitted to Ecology within five (5) days, unless requested earlier by Ecology.

Any time turbidity sampling indicates turbidity is 250 nephelometric turbidity units (NTU) or greater or water transparency is 6 centimeters or less, the Ecology regional office will be notified by phone within 24 hours of analysis as required by permit condition S5.A (see Section 5.0 of this SWPPP for contact information).

In accordance with permit condition S2.A, a complete application form will be submitted to Ecology and the appropriate local jurisdiction (if applicable) to be covered by the General Permit.

Appendix A – Site Plans

See Plans.

Appendix B – Construction BMPs

Stabilized Construction Entrance (BMP C105)

Silt Fence (BMP C233)

Storm Drain Inlet Protection (BMP C220)

Infiltration Trench (BMP T7.20)

Temporary and Permanent Seeding (BMP C120)

Mulching (BMP C121)

Nets and Blankets (BMP C122)

Plastic Covering (BMP C123)

Topsoiling (BMP C125)

Dust Control (BMP C140)

Early application of gravel base on areas to be paved

Outlet Protection (BMP C209)

Appendix C – Alternative BMPs

The following includes a list of possible alternative BMPs for each of the 12 elements not described in the main SWPPP text. This list can be referenced in the event a BMP for a specific element is not functioning as designed and an alternative BMP needs to be implemented.

Element #1 - Mark Clearing Limits

High Visibility Plastic or Metal Fence (BMP C103)

Stake and Wire Fence (BMP C104)

Element #2 - Establish Construction Access

Wheel Wash (BMP C106)

Water Bars (BMP C203)

Element #3 - Control Flow Rates

Wattles (BMP C235)

Element #4 - Install Sediment Controls

Straw Bale Barrier (BMP C230)

Gravel Filter Berm (BMP C232)

Straw Wattles (BMP C235)

Portable Water Storage Tanks (Baker Tanks)

Construction Stormwater Chemical Treatment (BMP C250)

Construction Stormwater Filtration (BMP C251)

Element #5 - Stabilize Soils

Polyacrylamide (BMP C126)

Element #6 - Protect Slopes

Straw Wattles (BMP C235)

Surface Roughening (BMP C240)

Element #8 - Stabilize Channels and Outlets

Level Spreader (BMP C206)

Check Dams (BMP C207)

Element #9 – Control Pollutants

Concrete Handling (BMP C151)

Construction Stormwater Chemical Treatment (BMP C250)

Construction Stormwater Filtration (BMP C251)

Element #10 - Control Dewatering

Vegetated Filtration (BMP C236)

Additional Advanced BMPs to Control Dewatering:

Appendix D – General Permit

Appendix E – Site Inspection Forms (and Site Log)

The results of each inspection shall be summarized in an inspection report or checklist that is entered into or attached to the site log book. It is suggested that the inspection report or checklist be included in this appendix to keep monitoring and inspection information in one document, but this is optional. However, it is mandatory that this SWPPP and the site inspection forms be kept onsite at all times during construction, and that inspections be performed and documented as outlined below.

At a minimum, each inspection report or checklist shall include:

- a. Inspection date/times
- b. Weather information: general conditions during inspection, approximate amount of precipitation since the last inspection, and approximate amount of precipitation within the last 24 hours.
- c. A summary or list of all BMPs that have been implemented, including observations of all erosion/sediment control structures or practices.
- d. The following shall be noted:
 - i. locations of BMPs inspected,
 - ii. locations of BMPs that need maintenance,
 - iii. the reason maintenance is needed,
 - iv. locations of BMPs that failed to operate as designed or intended, and
 - v. locations where additional or different BMPs are needed, and the reason(s) why
- e. A description of stormwater discharged from the site. The presence of suspended sediment, turbid water, discoloration, and/or oil sheen shall be noted, as applicable.
- f. A description of any water quality monitoring performed during inspection, and the results of that monitoring.
- g. General comments and notes, including a brief description of any BMP repairs, maintenance or installations made as a result of the inspection.
- h. A statement that, in the judgment of the person conducting the site inspection, the site is either in compliance or out of compliance with the terms and conditions of the SWPPP and the NPDES permit. If the site inspection indicates that the site is out of compliance, the inspection report shall include a summary of the remedial actions required to bring the site back into compliance, as well as a schedule of implementation.

Stormwater Pollution Prevention Plan

- i. Name, title, and signature of person conducting the site inspection; and the following statement: “I certify under penalty of law that this report is true, accurate, and complete, to the best of my knowledge and belief”.

When the site inspection indicates that the site is not in compliance with any terms and conditions of the NPDES permit, the Permittee shall take immediate action(s) to: stop, contain, and clean up the unauthorized discharges, or otherwise stop the noncompliance; correct the problem(s); implement appropriate Best Management Practices (BMPs), and/or conduct maintenance of existing BMPs; and achieve compliance with all applicable standards and permit conditions. In addition, if the noncompliance causes a threat to human health or the environment, the Permittee shall comply with the Noncompliance Notification requirements in Special Condition S5.F of the permit.

Site Inspection Form

General Information

Project Name:		Title:	
Inspector Name:		CESCL # :	
Date:		Time:	
Inspection Type:	<input type="checkbox"/> After a rain event <input type="checkbox"/> Weekly <input type="checkbox"/> Turbidity/transparency benchmark exceedance <input type="checkbox"/> Other		

Weather			
Precipitation	Since last inspection	In last 24 hours	
Description of General Site Conditions:			

Inspection of BMPs

Element 1: Mark Clearing Limits

BMP:

Location	Inspected		Functioning			Problem/Corrective Action
	Y	N	Y	N	NIP	

BMP:

Location	Inspected		Functioning			Problem/Corrective Action
	Y	N	Y	N	NIP	

Element 2: Establish Construction Access

BMP:

Location	Inspected		Functioning			Problem/Corrective Action
	Y	N	Y	N	NIP	

BMP:

Location	Inspected		Functioning			Problem/Corrective Action
	Y	N	Y	N	NIP	

Stormwater Pollution Prevention Plan

--	--

Element 3: Control Flow Rates

BMP:

Location	Inspected		Functioning			Problem/Corrective Action
	Y	N	Y	N	NIP	

BMP:

Location	Inspected		Functioning			Problem/Corrective Action
	Y	N	Y	N	NIP	

Element 4: Install Sediment Controls

BMP:

Location	Inspected		Functioning			Problem/Corrective Action
	Y	N	Y	N	NIP	

BMP:

Location	Inspected		Functioning			Problem/Corrective Action
	Y	N	Y	N	NIP	

BMP:

Location	Inspected		Functioning			Problem/Corrective Action
	Y	N	Y	N	NIP	

BMP:

Location	Inspected		Functioning			Problem/Corrective Action
	Y	N	Y	N	NIP	

BMP:

Location	Inspected		Functioning			Problem/Corrective Action
	Y	N	Y	N	NIP	

Stormwater Pollution Prevention Plan

Element 5: Stabilize Soils

BMP:

Location	Inspected		Functioning			Problem/Corrective Action
	Y	N	Y	N	NIP	

BMP:

Location	Inspected		Functioning			Problem/Corrective Action
	Y	N	Y	N	NIP	

BMP:

Location	Inspected		Functioning			Problem/Corrective Action
	Y	N	Y	N	NIP	

BMP:

Location	Inspected		Functioning			Problem/Corrective Action
	Y	N	Y	N	NIP	

Element 6: Protect Slopes

BMP:

Location	Inspected		Functioning			Problem/Corrective Action
	Y	N	Y	N	NIP	

BMP:

Location	Inspected		Functioning			Problem/Corrective Action
	Y	N	Y	N	NIP	

BMP:

Location	Inspected		Functioning			Problem/Corrective Action
	Y	N	Y	N	NIP	

Stormwater Pollution Prevention Plan

Element 7: Protect Drain Inlets

BMP:

Location	Inspected		Functioning			Problem/Corrective Action
	Y	N	Y	N	NIP	

BMP:

Location	Inspected		Functioning			Problem/Corrective Action
	Y	N	Y	N	NIP	

BMP:

Location	Inspected		Functioning			Problem/Corrective Action
	Y	N	Y	N	NIP	

Element 8: Stabilize Channels and Outlets

BMP:

Location	Inspected		Functioning			Problem/Corrective Action
	Y	N	Y	N	NIP	

BMP:

Location	Inspected		Functioning			Problem/Corrective Action
	Y	N	Y	N	NIP	

BMP:

Location	Inspected		Functioning			Problem/Corrective Action
	Y	N	Y	N	NIP	

BMP:

Location	Inspected		Functioning			Problem/Corrective Action
	Y	N	Y	N	NIP	

Stormwater Pollution Prevention Plan

Element 9: Control Pollutants

BMP:

Location	Inspected		Functioning			Problem/Corrective Action
	Y	N	Y	N	NIP	

BMP:

Location	Inspected		Functioning			Problem/Corrective Action
	Y	N	Y	N	NIP	

Element 10: Control Dewatering

BMP:

Location	Inspected		Functioning			Problem/Corrective Action
	Y	N	Y	N	NIP	

BMP:

Location	Inspected		Functioning			Problem/Corrective Action
	Y	N	Y	N	NIP	

BMP:

Location	Inspected		Functioning			Problem/Corrective Action
	Y	N	Y	N	NIP	

Stormwater Discharges From the Site		
Observed?	Problem/Corrective Action	

SEPARATOR SHEET

APPENDIX F

Environmental Documentation



CRITICAL AREAS REPORT

October 2, 2023



13th Street Gas Station
Camas, WA

Prepared for

PAK USA Camas, LLC
c/o Taz Khan
3993 NW Currawong Court
Camas, WA 98607
(512) 779-4999

Prepared by

Ecological Land Services

1157 3rd Avenue, Suite 220A • Longview, WA 98632
(360) 578-1371 • Project Number 3934.01

SIGNATURE PAGE

The information in this report was compiled and prepared under the supervision and direction of the undersigned.

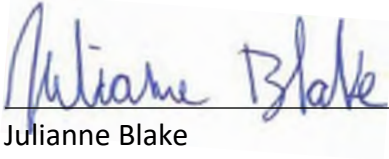
A handwritten signature in blue ink that reads "Julianne Blake". The signature is written in a cursive style and is positioned above a horizontal line.

Julianne Blake
Biologist III

TABLE OF CONTENTS

INTRODUCTION	1
SITE DESCRIPTION	1
METHODOLOGY	1
VEGETATION	2
SOILS	2
HYDROLOGY	2
PRECIPITATION	2
CRITICAL AREA INVENTORIES	3
NATIONAL WETLANDS INVENTORY	3
CLARK COUNTY CRITICAL AREA INVENTORY	3
WASHINGTON DEPARTMENT OF NATURAL RESOURCES STREAM TYPE	3
PRIORITY HABITATS AND SPECIES.....	3
CRITICAL AREAS SUMMARY	4
PRIORITY HABITATS	4
<i>Oregon White Oak</i>	4
LIMITATIONS	5
REFERENCES	6

TABLES (IN TEXT)

Table 1. Precipitation Summary.....	3
Table 2. Oak Summary	4

FIGURES AND PHOTOPLATES

Figure 1	Vicinity Map
Figure 2	Existing Conditions
Figure 3	NRCS Soil Survey
Figure 4	USFWS National Wetlands Inventory
Figure 5	Clark County Critical Areas
Figure 6	WDNR Stream Type Map
Figure 7	WDFW Priority Habitats and Species
Photoplates	1 – 2

APPENDICES

Appendix A – Routine Determination Method and Plant Indicator Rating Definitions
Appendix B – Wetland Determination Data Form
Appendix C – Precipitation Information

INTRODUCTION

Ecological Land Services, Inc. (ELS) was contracted by PAK USA Camas, LLC to complete a critical areas assessment for wetlands and fish and wildlife habitat conservation areas, for the purpose of future development. The site is approximately 0.97 acres and consists of Clark County Tax Parcel 176148000 located at 20101 NE 13th Street within the NW ¼ of Section 29, Township 2 North, and Range 3 East of the Willamette Meridian in Camas, Washington (Figure 1). Field work was conducted on August 29, 2023. This report summarizes the findings of the site visit in accordance with *Camas Municipal Code (CMC) Title 16 Environment* (2023).

SITE DESCRIPTION

The 0.97-acre site consists of Clark County Tax Parcel 176148000 and is accessed by a paved driveway off NE 13th Street. The site is zoned as Business Park (BP) and currently contains a single-family mobile home, shed, carport, and paved driveway. The site is bordered to the north by NE 13th Street, to the east by NW Friberg-Strunk Street, to the south by undeveloped land and commercial development in progress, and to the west by undeveloped land and a single-family residence (Figure 2).

Vegetation onsite consists primarily of regularly mowed grasses, ornamental shrubs, and coniferous and deciduous trees. Topography onsite is generally flat with NE 13th Street and NW Friberg-Strunk Street roughly two feet higher in elevation than the site. One Oregon white oak (*Quercus garryana*, FACU) was identified onsite along the southern property boundary.

METHODOLOGY

The property was evaluated for the presence of wetlands using the Routine Determination Method according to the U.S. Army Corps of Engineers' 1987 *Wetland Delineation Manual* and the *Regional Supplement to the Corps of Engineers' Wetland Delineation Manual* (Environmental Laboratory 1987); *Western Mountains, Valleys, and Coast Region (Version 2.0)* (Corps 2010). The Routine Determination Method and defining wetland criteria are discussed further in Appendix A. Wetlands are regulated as "Waters of the United States" by the U.S. Army Corps of Engineers (Corps) and as "Waters of the State" by the Washington Department of Ecology (Ecology), and locally by The City of Camas (City).

ELS biologists evaluated the property on August 29, 2023, to determine the presence or absence of critical areas including streams, wetlands, and priority habitats. One Oregon white oak (oak) was identified onsite, and no wetlands, streams, or other priority habitats were identified. Vegetation, soil, and hydrology data were collected from one test plot (TP) to determine whether wetlands were present onsite. No wetlands were present onsite. TP-1 was taken in the southwest corner of the site in an area with mapped hydric soils. The oak dripline and test plot location were mapped using a hand-held Global Positioning System (GPS) unit capable of sub-meter accuracy under ideal conditions.

VEGETATION

General vegetation consists primarily of regularly mowed grass and ornamental trees and shrubs (Photoplates 1 and 2). One Oregon white oak was observed along the southern site boundary. The plant indicator status following the plant scientific name is defined by the *National Wetland Plant List Indicator Rating Definitions* (Corps 2012) and can be found in Appendix A.

Dominant vegetation consisted of domestic apple trees (*Malus* spp., assumed FAC), Japanese maple (*Acer palmatum*, UPL), rhododendron (*Rhododendron* spp., assumed FACU), Oregon white oak, osoberry (*Oemleria cerasiformis*, FACU), mowed English hawthorn saplings (*Crataegus monogyna*, FAC), swordfern (*Polystichum munitum*, FACU), and fescue grass (*Festuca* spp., assumed FAC). The wetland determination data form contains vegetation information at TP-1 and is in Appendix B.

SOILS

The Natural Resources Conservation Service (NRCS) designates soils onsite as cove silty clay loam, thin solum, 0 to 3 percent slopes (CwA), and Wind River gravelly loam, 0 to 8 percent slopes (WrB) (Figure 3, NRCS 2023B). Of the two soil types found onsite, cove silty clay loam, thin solum, 0 to 3 percent slopes is designated as hydric.

According to soil profile descriptions developed by NRCS, cove silty clay loam, thin solum, is characterized as a poorly drained soil, forming on floodplains, with a depth to water table of 0 to 12 inches below ground surface (BGS). A typical soil profile includes silty clay loam from 0 to 14 inches, clay from 14-21 inches, and silt loam from 21 to 60 inches BGS. Wind River gravelly loam is categorized as a somewhat excessively drained soil with a typical soil profile of gravelly loam from 0 to 4 inches, coarse sandy loam from 4 to 24 inches, and loamy coarse sand from 24 to 60 inches BGS. Wind River gravelly loam forms on floodplains from alluvium parent material and has an average depth to water table of more than 80 inches.

Evaluated soils were characterized as loamy with a value of 4, and a chroma of 3, with no observations of redoximorphic concentrations and meeting no hydric soil indicators. Mapped hydric soils do not necessarily mean that an area is or is not a wetland—hydrology, hydrophytic wetland vegetation, and hydric soils must all be present to classify an area as a wetland. The test plot data form is in Appendix B.

HYDROLOGY

No evidence of wetland hydrology was observed at TP-1 or onsite.

PRECIPITATION

Precipitation data was gathered from the NOAA Regional Climate Centers *Clark County, Washington, WETS Station: Battle Ground*, which is located closest to the site. No rainfall occurred the day of the site visit or in the two weeks prior. Rainfall in June, July, and August was below exceedance levels and approximately 94 percent of August rainfall occurred prior to the site visit. Furthermore, review of the USACE Antecedent Precipitation Tool (APT) indicates rainfall

in the two months preceding the August 29th site visit was drier than normal with a score of 6. A copy of the APT data is provided in Appendix C. Table 1 summarizes the precipitation data.

Table 1. Precipitation Summary

Precipitation (inches)								
Date of Visit	Two Weeks Prior	3 Months Prior		30%	70%	DAREM ¹		
		30 Days Ending	Observed			Value	Weight	Total
8/29/23	8/15/23 – 8/28/23	8/29/23	0.05	0.25	0.99	1	3	3
0.0	0.0	7/30/23	0.0	0.24	0.82	1	2	2
		6/30/23	0.83	1.48	2.80	1	1	1
Rainfall 3 months prior was: drier than normal (sum 6-9), normal (sum 10-14), wetter than normal (sum 15-18). ¹								6
Year to Date Average Rainfall ^{2,3} : 50.06								
Year to Date Actual Rainfall ³ : 45.32								

¹ Direct Antecedent Rainfall Evaluation Methods (Sumner et al 2009)

² Includes 94% of August Rainfall

³ Based on a water year, October 2022 – August 2023

CRITICAL AREA INVENTORIES

NATIONAL WETLANDS INVENTORY

The National Wetlands Inventory (NWI) map does not indicate any wetlands onsite (Figure 4, USFWS 1988). ELS agrees with the NWI mapping, as no wetlands were identified onsite.

CLARK COUNTY CRITICAL AREA INVENTORY

The Clark County Critical Area Inventory (CCCAI) map does not indicate any wetlands onsite but does indicate potential wetlands presence on the property to the south. Hydric soils are mapped along the eastern site boundary and the southwestern corner, and a habitat area is mapped over the majority of the eastern portion of the site (Figure 5). ELS partially agrees with the CCAI as no wetlands were identified onsite and one oak was observed in the vicinity of the mapped habitat area. The potential wetlands mapped to the south of the site are located in the footprint of a commercial development that has received permit approval. However, ELS does not agree with the extent of the mapped habitat area as only one oak was identified onsite and no other critical habitats were identified.

WASHINGTON DEPARTMENT OF NATURAL RESOURCES STREAM TYPE

The Washington Department of Natural Resources (WDNR) Stream Type Map does not depict any streams onsite (Figure 6, WDNR 2023). ELS agrees with the WDNR mapping as no streams were observed onsite.

PRIORITY HABITATS AND SPECIES

The Washington Department of Fish and Wildlife (WDFW) Priority Habitats and Species (PHS) maps indicate oak woodland and caves or cave-rich areas on the southern boundary of the site

and within 300 feet of the site to the southwest (Figure 7, WDFW 2023). ELS confirmed the presence of a single oak along the southern site boundary, but no oak woodlands or caves were observed onsite.

Critical area inventory maps are typically used to gather general information about a region and due to the large scale necessary for regional mapping, are limited in accuracy for localized analyses.

CRITICAL AREAS SUMMARY

PRIORITY HABITATS

OREGON WHITE OAK

Oregon white oaks are considered a priority habitat and are regulated by the Washington Department of Fish and Wildlife (WDFW) and locally by the City of Camas. According to WDFW's Management Recommendations for Washington's priority habitats: Oregon white oak woodlands (Larsen and Morgan, 1998), in urban or urbanizing areas west of the Cascades, priority oak habitat is defined as single oaks, stands of pure oak, or oak/conifer associations, one acre or greater in size. WDFW may also consider individual Oregon white oak trees a priority habitat when found to be particularly valuable to wildlife [i.e., contains many cavities, has a large diameter at breast height (DBH), is used by priority species, or has a large canopy]. The site is within the City of Camas. WDFW recommendation is that in urban and urbanizing areas, single trees should be maintained if they are deemed important to species highly associated with Oregon white oak. Oaks and their associated floras comprise distinct woodland ecosystems with various plant communities providing valuable habitat that contributes to wildlife diversity; oak woodlands provide a mix of feeding, resting, and breeding habitat for many wildlife species (Larsen and Morgan 1998).

The WDFW Priority Habitats and Species online mapping tool depicts oak woodlands within the vicinity of the observed oak along the southern site boundary. One oak tree measuring approximately 52 inches DBH was mapped along the southern site boundary during site reconnaissance (Figure 2). The oak has several live and dead branches, cavities, and has canopy connectivity with other trees in the vicinity but is not connected with other oaks. The oak location was mapped using a GPS system capable of submeter accuracy in ideal conditions. According to *CMC 16.61.010(3)(a)*, individual Oregon white oak trees with a twenty-inch DBH are considered a priority habitat.

Table 2: Oak Summary

Canopy Area	Diameter at Breast Height	Number of Trunks	Noteworthy Habitat Features
0.08 acres	52 inches	1	<ul style="list-style-type: none"> • Canopy is interconnected with adjacent trees, but not other oaks • Two large cavities

LIMITATIONS

ELS bases this report's determinations on standard scientific methodology and best professional judgment. In our opinion, local, state, and federal regulatory agencies should agree with our determinations. However, the information contained in this report should be considered preliminary and used at your own risk until it has been approved in writing by the appropriate regulatory agencies. ELS is not responsible for the impacts of any changes in environmental standards, practices, or regulations after the date of this report.

REFERENCES

- City of Camas. 2023. *Camas Municipal Code (CMC) Title 16 Environment*. Camas, Washington. July 31, 2023.
- Environmental Laboratory. 1987. *Corps of Engineers Wetland Delineation Manual*, Technical Report Y-87-1. U.S. Army Corps of Engineer Waterways Experiment Station, Vicksburg, Mississippi.
- Federal Geographic Data Committee (FGDC). 2013. *Classification of Wetlands and Deepwater Habitats of the United States*. FGDC-STD-004-2013. Second Edition. Wetlands Subcommittee, Federal Geographic Data Committee and U.S. Fish and Wildlife Service, Washington, DC.
- Larsen, Eric M. and Morgan, John T. 1998. *Management Recommendations for Washington's Priority Habitats Oregon White Oak Woodlands*. Washington Department of Fish and Wildlife (WDFW). January 1998.
- Natural Resource Conservation Service (NRCS). 2008. *Hydrogeomorphic Wetland Classification System: An Overview and Modification to Better Meet the Needs of the Natural Resources Conservation Service*. United States Department of Agriculture Technical Note, #190-8-76
- Natural Resources Conservation Service (NRCS). 2023A. *Soil Survey of Clark County, Washington*. <https://websoilsurvey.sc.egov.usda.gov/App/HomePage.htm>. Accessed October 2023.
- Natural Resources Conservation Service (NRCS). 2023B. *Washington State Hydric Soils List*. <http://websoilsurvey.nrcs.usda.gov/app/WebSoilSurvey.aspx>. Accessed October 2023.
- NOAA Regional Climate Centers AgACIS website WETS Station: Battle Ground, WA Station. <https://agacis.rcc-acis.org/?fips=53011>. Accessed October 2023.
- Sumner, Jaclyn P., Vepraskas, Michael J., and Kolka, Randall K. 2009. *Methods to Evaluate Normal Rainfall for Short-term Wetland Hydrology Assessment*. *Wetlands*, Vol. 29, No.3 September 2009. Pp. 1049-1062. The Society of Wetland Scientists.
- U.S. Army Corps of Engineers. 2010. *Final Regional Supplement to the Corps of Engineers Wetland Delineation Manual: Western Mountains, Valleys, and Coast Region (Version 2.0)*, ed. J.S. Wakeley, R.W. Lichvar, and C.V. Noble. ERDC/EL TR-08-13. Vicksburg, Mississippi: U.S. Army Engineer Research and Development Center.
- U.S. Army Corps of Engineers. 2012. *National Wetland Plant List Indicator Rating Definitions*, ed. R.W. Lichvar, N.C. Melvin, M.L. Butterwick, and W.N. Kirchner. ERDC/CRREL TN-12-1. Vicksburg, Mississippi: U.S. Army Engineer Research and Development Center.
- U.S. Fish and Wildlife Service (USFWS). 1988. *National Wetlands Inventory (NWI)*. <http://wetlandsfws.er.usgs.gov/wtInds/launch.html>. Accessed October 2023.

U.S. Army Corps of Engineers. 2023. *Antecedent Precipitation Tool (Version 1.0)*. Jason Deters. Accessed October 2023.

Washington Department of Fish and Wildlife (WDFW). 2023. *Priority Habitats and Species (PHS) on the Web*. <https://geodataservices.wdfw.wa.gov/hp/phs/>. Accessed October 2023.

Washington Department of Natural Resources (WDNR). 2023. *Forest Practices Application Mapping Tool*.
<https://fpamt.dnr.wa.gov/2d-view#activity?-13635352,-13631683,5720608,5722297>.
Accessed October 2023.

FIGURES AND PHOTOPLATES

9/29/2023 12:51 PM C:\Users\Jennifer\Box\ELSWA\Clark\Camas\3934-PAK USA Camas, LLC\3934.01-13th St Feasibility\3934.01-Figures CAD Only\3934.01_DL.dwg Jennifer

WASHINGTON



SITE

45.6321° Latitude
-122.4664° Longitude

LOCATION MAP

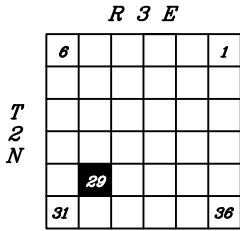

PROJECT VICINITY MAP

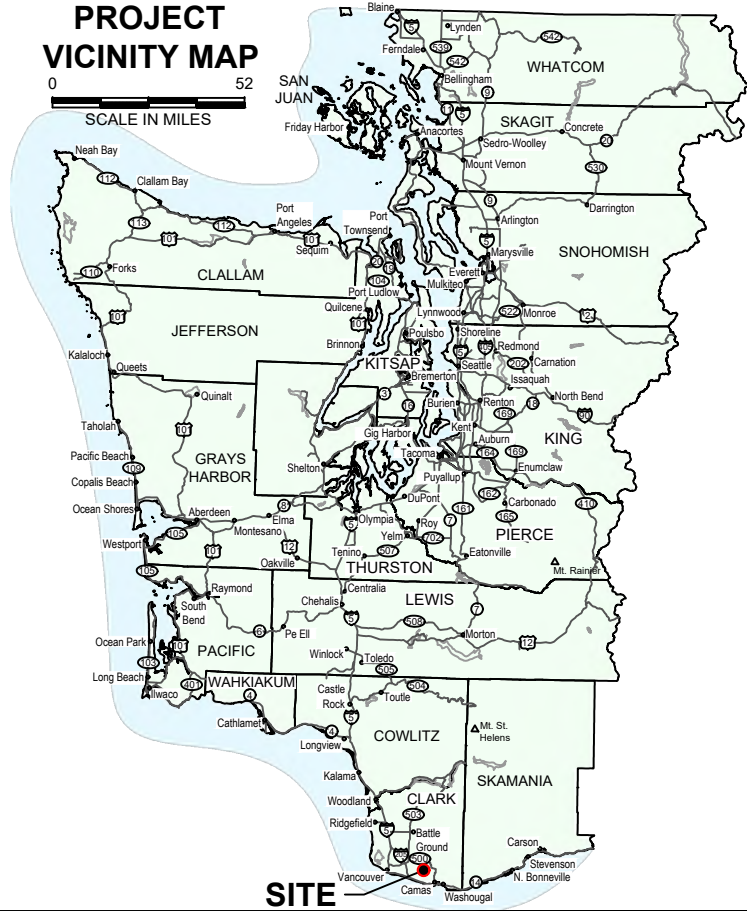

SITE

NOTE:

Quadrangle topographic map from USGS.

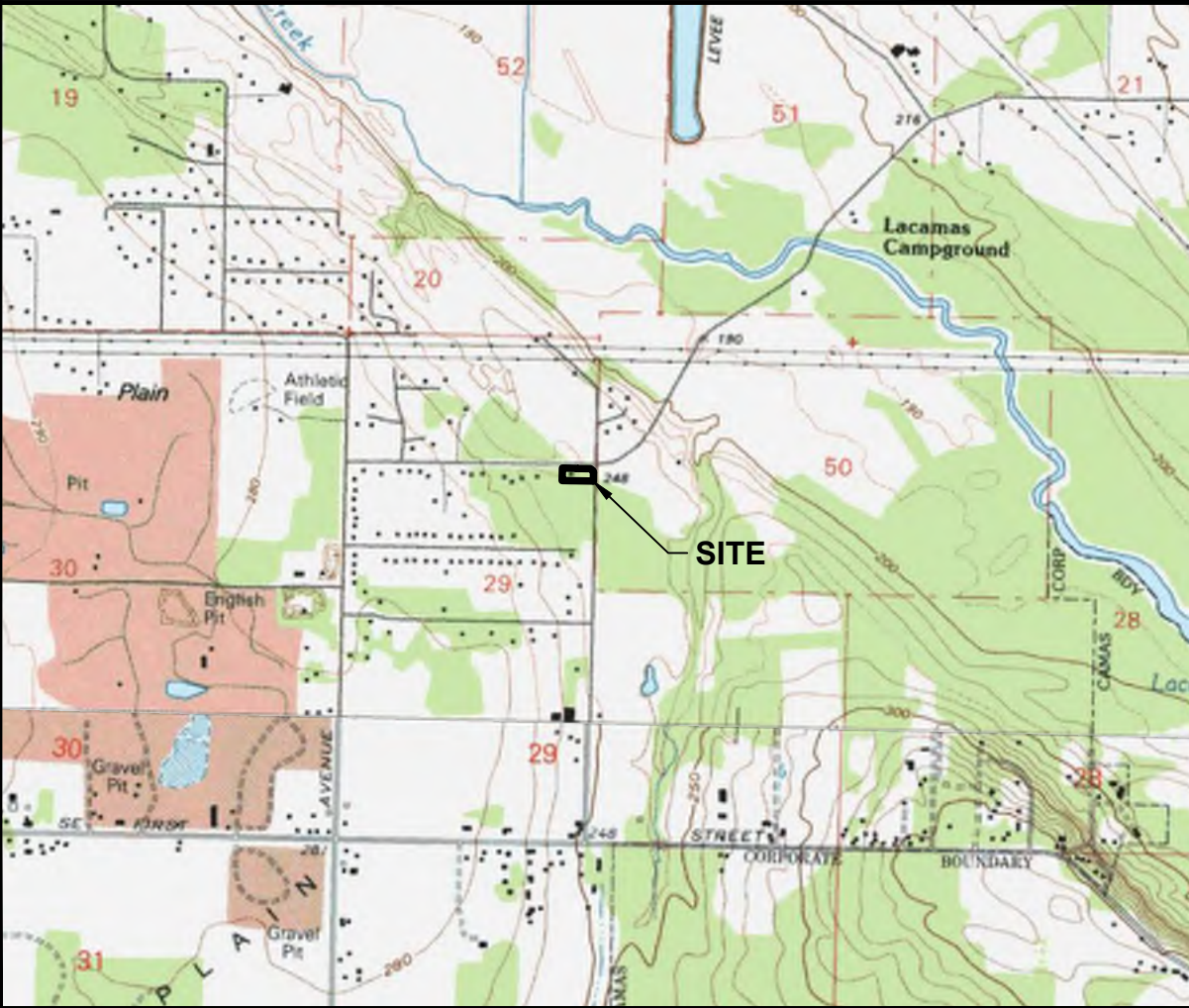
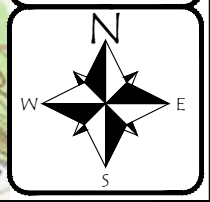
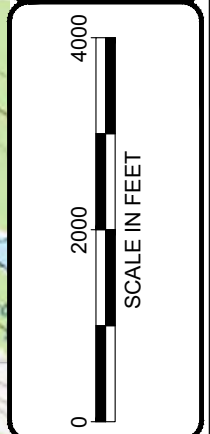
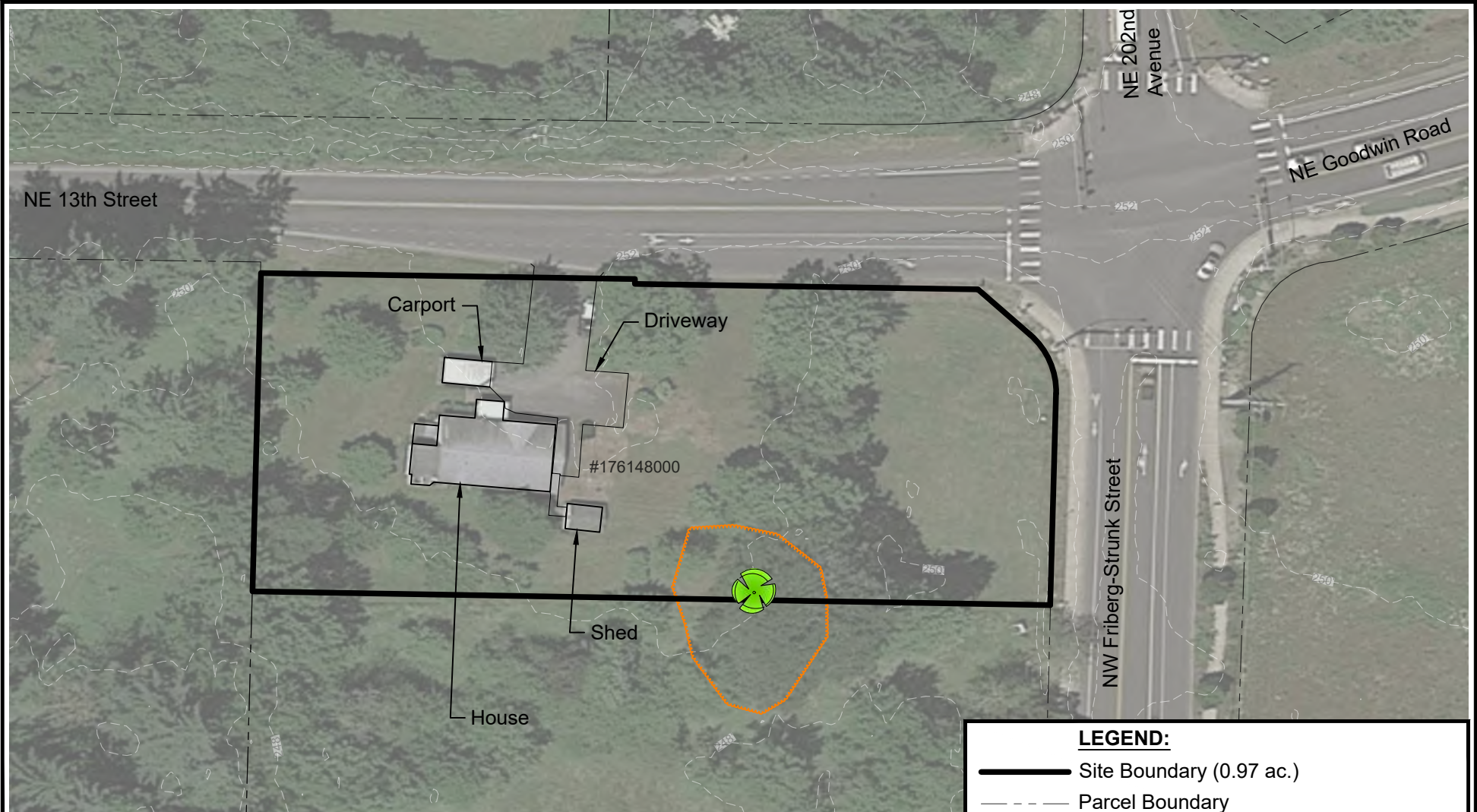

Figure 1
VICINITY MAP
13th Street Gas Station
PAK USA Camas, LLC
City of Camas, Clark County, Washington
Section 29, Township 2N, Range 3E, W.M.

DATE: 9/29/23
DWN: JJK
REQ. BY: JB
PRJ. MGR: JB
CHK:
PROJECT NO:
3934.01

1157 3rd Ave., Suite 220A
Longview, WA 98632
Phone: (360) 578-1371
Fax: (360) 414-9305
www.eco-land.com





NOTE(S):

1. Aerial from Google Earth™ (6/17/2021).
2. Site boundary, oak tree location, and oak dripline surveyed by PLS Engineering, Inc.
3. Parcel data from Clark County GIS Department.
4. Topography from 2013 Clark County Lidar provided by WDNR at <https://lidarportal.dnr.wa.gov>.

LEGEND:

- Site Boundary (0.97 ac.)
- Parcel Boundary
- Oregon White Oak Tree Location
- Oak Dripline (0.08 ac. total/0.03 ac. onsite)
- 1' Contours

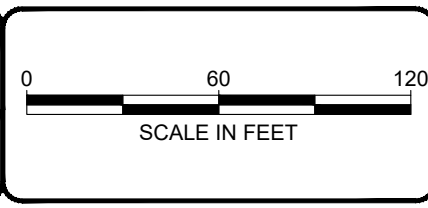
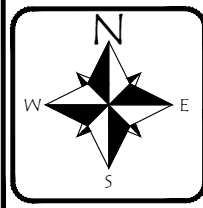

1157 3rd Ave., Suite 220A
 Longview, WA 98632
 Phone: (360) 578-1371
 Fax: (360) 414-9305
www.eco-land.com

DATE: 9/29/23
 DWN: JKJ
 REQ. BY: JB
 PRJ. MGR: JB
 CHK:
 PROJECT NO:
 3934.01

Figure 2
EXISTING CONDITIONS
 13th Street Gas Station
 PAK USA Camas, LLC
 City of Camas, Clark County, Washington
 Section 29, Township 2N, Range 3E, W.M.

9/29/2023 12:51 PM C:\Users\Jennifer\Box\ELSWA\Clark\Camas\3934-PAK USA Camas, LLC\3934.01-13th St Feasibility\3934.01-Figures CAD Only\3934.01 DL.dwg Jennifer

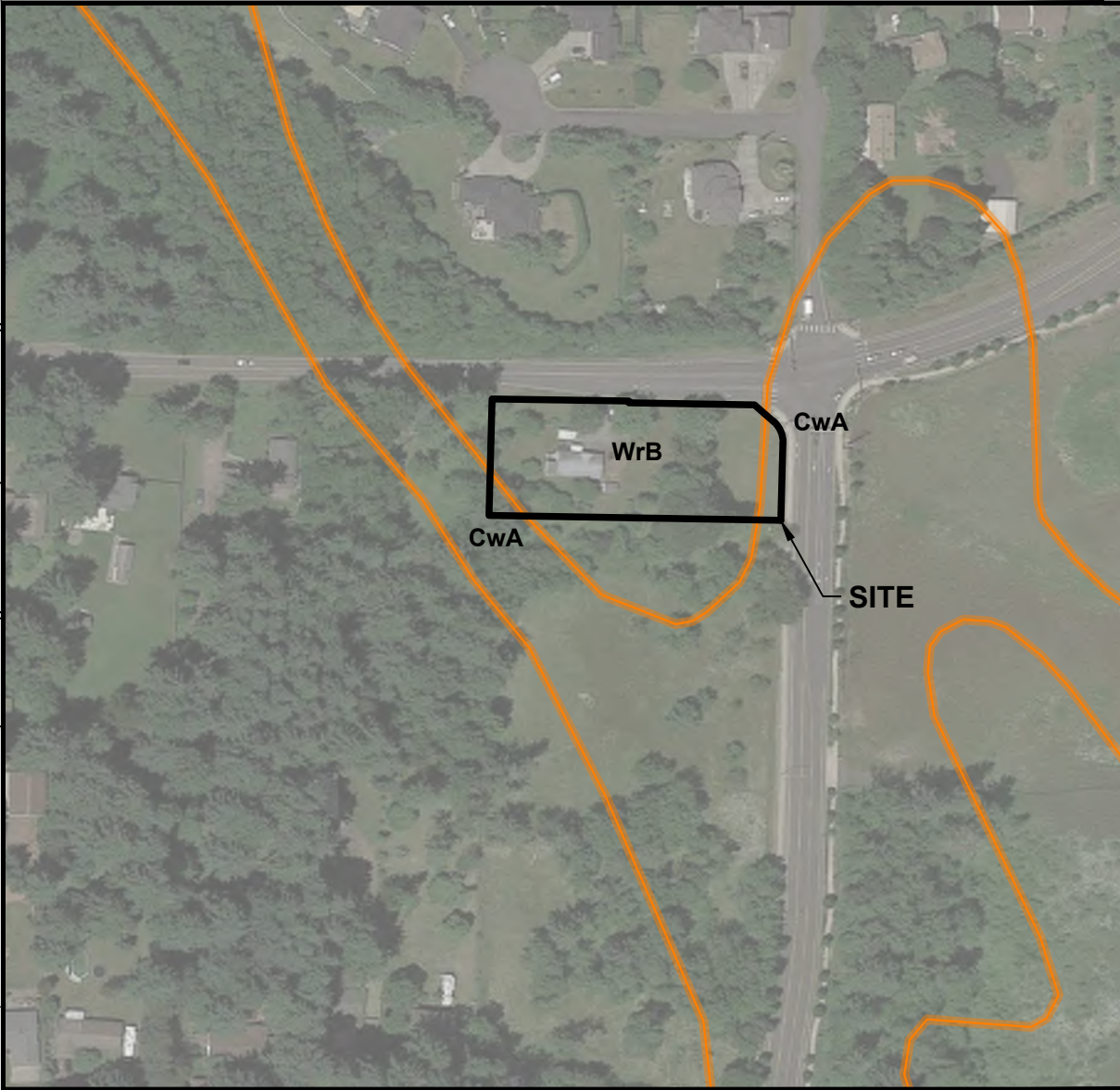

LEGEND:

- Site Boundary
- NRCS Soil Boundary
- CwA** Cove silty clay loam, thin solum, 0 to 3 percent slopes. Hydric.
- WrB** Wind River gravelly loam, 0 to 8 percent slopes. Not hydric.

NOTE(S):

1. Map provided on-line by NRCS at web address:
<http://websoilsurvey.nrcs.usda.gov/app/>

Figure 3
NRCS SOIL SURVEY
 13th Street Gas Station
 PAK USA Camas, LLC
 City of Camas, Clark County, Washington
 Section 29, Township 2N, Range 3E, W.M.

DATE: 9/29/23
 DWN: JKJ
 REQ. BY: JB
 PRJ. MGR: JB
 CHK:
 PROJECT NO:
 3934.01

1157 3rd Ave., Suite 220A
 Longview, WA 98632
 Phone: (360) 578-1371
 Fax: (360) 414-9305
www.eco-land.com

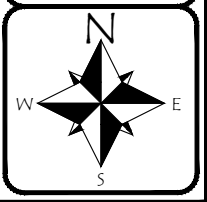
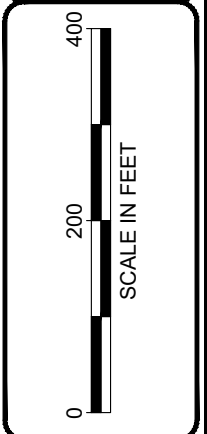

9/29/2023 12:51 PM C:\Users\Jennifer\Box\ELSWA\Clark\Camas\3934-PAK USA Camas, LLC\3934.01-13th St Feasibility\3934.01-Figures CAD Only\3934.01_DL.dwg Jennifer



No mapped wetlands indicated onsite by US Fish & Wildlife Service.

LEGEND:

-  Site Boundary
-  Wetlands
-  Riverine

NOTE(S):

1. Map provided on-line by US Fish & Wildlife Service at web address:
<https://www.fws.gov/program/national-wetlands-inventory/wetlands-mapper>

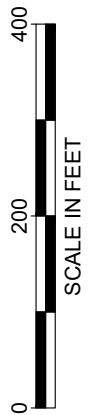

1157 3rd Ave., Suite 220A
 Longview, WA 98632
 Phone: (360) 578-1371
 Fax: (360) 414-9305
www.eco-land.com

DATE: 9/29/23
 DWN: JKJ
 REQ. BY: JB
 PRJ. MGR: JB
 CHK:
 PROJECT NO:
 3934.01

Figure 4
USFWS NATIONAL WETLANDS INVENTORY
 13th Street Gas Station
 PAK USA Camas, LLC
 City of Camas, Clark County, Washington
 Section 29, Township 2N, Range 3E, W.M.

9/29/2023 12:51 PM C:\Users\Jennifer\Box\EL\SWA\Clark\Camas\3934-PAK USA Camas, LLC\3934.01-13th St Feasibility\3934.01-Figures CAD Only\3934.01_DL.dwg Jennifer

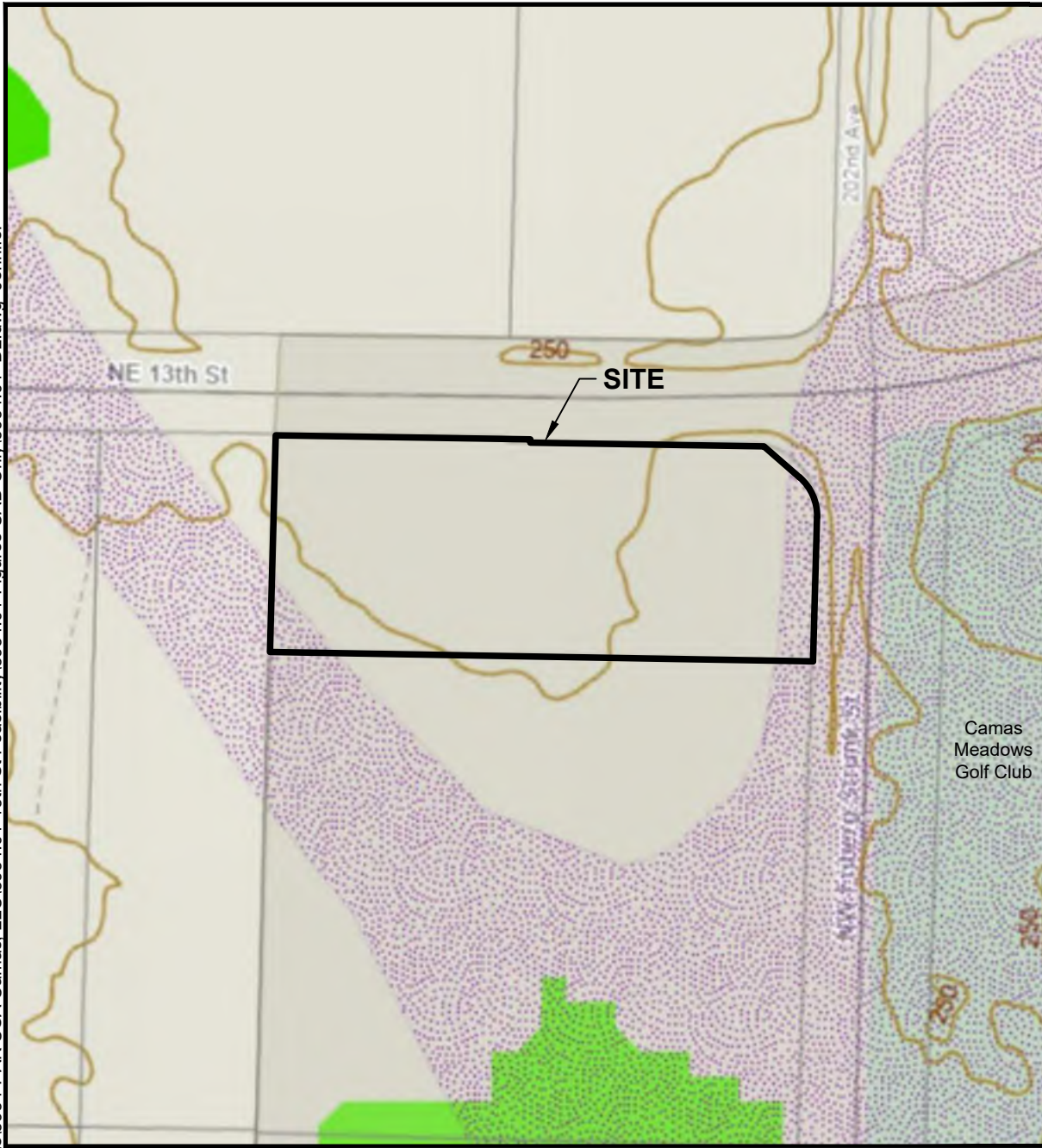

Figure 5
CLARK COUNTY CRITICAL AREAS
 13th Street Gas Station
 PAK USA Camas, LLC
 City of Camas, Clark County, Washington
 Section 29, Township 2N, Range 3E, W.M.

DATE: 9/29/23
 DWN: JJK
 REQ. BY: JB
 PRJ. MGR: JB
 CHK:
 PROJECT NO:
 3934.01

1157 3rd Ave., Suite 220A
 Longview, WA 98632
 Phone: (360) 578-1371
 Fax: (360) 414-9305
 www.eco-land.com



LEGEND:

- Site Boundary
- Hydric Soils
- Potential Wetlands Presence
- Permitted Wetland
- Contour Lines - 10 ft
- Slopes and Geologic Hazards Group Contour Lines

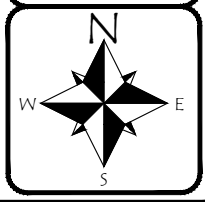
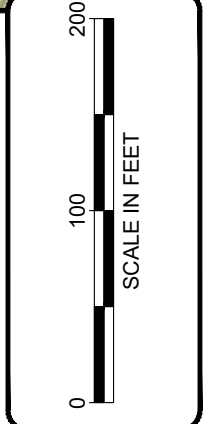

NOTE(S):

1. Map provided on-line by Clark County at web address: <https://gis.clark.wa.gov/mapsonline/index.cfm?site=Environmental>

9/29/2023 12:51 PM C:\Users\Jennifer\Box\ELSIWA\Clark\Camas\3934-PAK USA Camas.LLC\3934.01-13th St Feasibility\3934.01-Figures CAD Only\3934.01 DL.dwg Jennifer

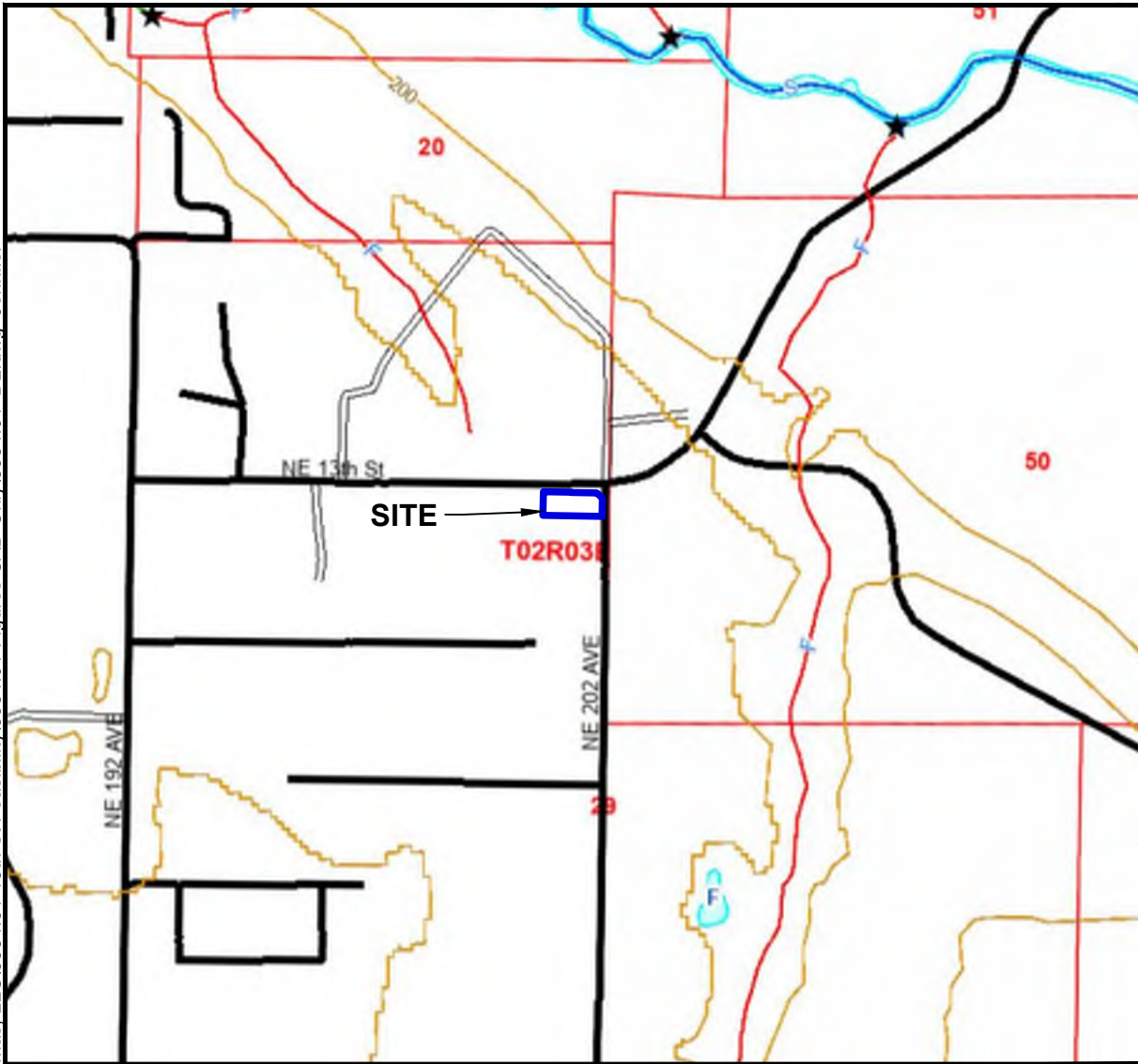

No mapped streams indicated onsite by the Washington State Department of Natural Resources (DNR).

LEGEND:

- Site Boundary
- 40-foot Contours
- 40 ft. Contours

Water Courses (FP)

- Type S
- Type F
- Type N, Np, Ns
- U, unknown
- - - X, non-typed per WAC 222-16

WRIA Boundaries

- WRIA Boundaries

DNR Roads

- Paved Road
- = Unpaved Road/Surface Unknown

Unpaved Road/Surface Unknown

- ★ Water Type Breaks (FP)

Figure 6
 WDNR STREAM TYPE MAP
 13th Street Gas Station
 PAK USA Camas, LLC
 City of Camas, Clark County, Washington
 Section 29, Township 2N, Range 3E, W.M.

DATE: 9/29/23
 DWN: JKJ
 REQ. BY: JB
 PRJ. MGR: JB
 CHK:
 PROJECT NO:
 3934.01

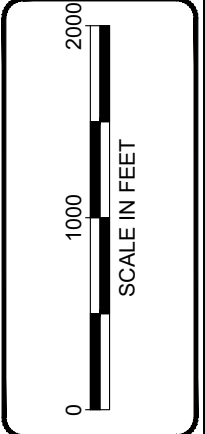

1157 3rd Ave., Suite 220A
 Longview, WA 98632
 Phone: (360) 578-1371
 Fax: (360) 414-9305
 www.eco-land.com

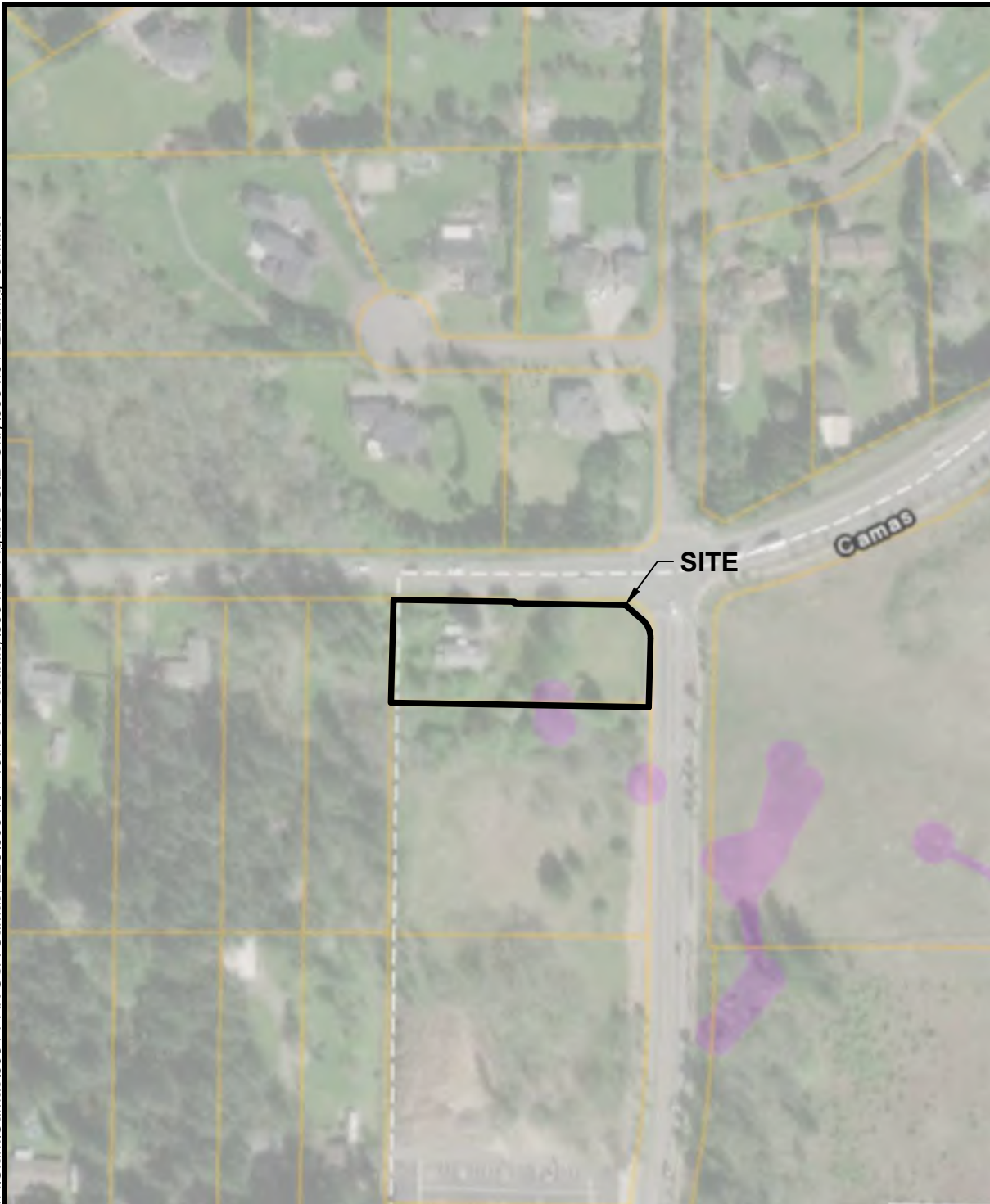

NOTE: Map provided on-line by Washington State Department of Natural Resources at web address: <http://fortress.wa.gov/dnr/app1/Fpars/viewer.htm>

9/29/2023 12:51 PM C:\Users\Jennifer\Box\ELSIWA\Clark\Camas\3934-PAK USA Camas.LLC\3934.01-13th St Feasibility\3934.01-Figures CAD Only\3934.01 DL.dwg Jennifer



- LEGEND:**
-  Site Boundary
 -  Parcel Boundary
 -  Oak Woodland - Habitat Feature
- By Township
Caves or Cave-rich Areas

NOTE: Map provided on-line by Washington State Department of Fish & Wildlife at web address:
<http://apps.wdfw.wa.gov/phsontheweb/>

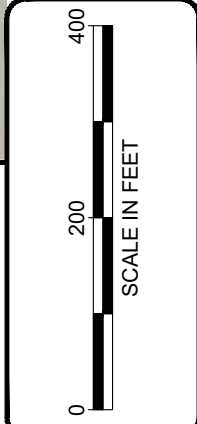

**Ecological
Land Services**

11157 3rd Ave., Suite 220A
 Longview, WA 98632
 Phone: (360) 578-1371
 Fax: (360) 414-9305
www.eco-land.com

DATE: 9/29/23
 DWN: JKJ
 REQ. BY: JB
 PRJ. MGR: JB
 CHK:
 PROJECT NO:
 3934.01

Figure 7
WDFW PRIORITY HABITAT AND SPECIES
 13th Street Gas Station
 PAK USA Camas, LLC
 City of Camas, Clark County, Washington
 Section 29, Township 2N, Range 3E, W.M.



Photo 1 was taken facing east and shows general conditions onsite.



Photo 2 was taken facing west and shows general conditions onsite. The oak is visible on the left.



Photo 3 shows the onsite Oregon white oak.



1157 3rd Ave., Suite 220A
Longview, WA 98632
Phone: (360) 578-1371
Fax: (360) 414-9305

DATE: 08.29.2023
DWN: JB
PRJ. MGR: JB
PROJ.#: 3934.01

Photoplate 1
13th Street Gas Station
Camas, WA
Section 29, Township 2N, Range 3E, W.M.



Photo 4 was taken facing north at TP-1 and shows general conditions onsite.



Photo 5 was taken facing west.



Photo 6 was taken facing west at TP-1.



Photo 7 was taken facing east at TP-1 and shows general conditions onsite.



1157 3rd Ave., Suite 220A
Longview, WA 98632
Phone: (360) 578-1371
Fax: (360) 414-9305

DATE: 08.29.2023
DWN: JB
PRJ. MGR: JB
PROJ.#: 3934.01

Photoplate 2
13th Street Gas Station
Camas, WA
Section 29, Township 2N, Range 3E, W.M.

APPENDIX A

ROUTINE DETERMINATION METHOD AND PLANT INDICATOR RATING DEFINITIONS

ROUTINE DETERMINATION METHOD

The Routine Determination Method is defined according to the U.S. Army Corps of Engineers' 1987 *Wetland Delineation Manual* and the *Regional Supplement to the Corps of Engineers' Wetland Delineation Manual* (Environmental Laboratory 1987); *Western Mountains, Valleys, and Coast Region (Version 2.0)* (Corps 2010). The Routine Determination Method examines three parameters – vegetation, soils, and hydrology – to determine if wetlands exist in a given area. Hydrology is critical in determining what is a wetland, but is often difficult to assess because hydrologic conditions can change periodically (hourly, daily, or seasonally). Consequently, it is necessary to determine if hydrophytic vegetation and hydric soils are present, which would indicate that water is present for a long enough duration to support a wetland plant community. By definition, wetlands are those areas that are inundated or saturated by surface or groundwater at a frequency and duration sufficient to support, and that under normal circumstances do support, a prevalence of vegetation typically adapted for life in saturated soil conditions.

VEGETATION INDICATOR STATUS

The indicator status, following the scientific names of plant species, indicates the likelihood of the species to be found in wetlands according to the *National Wetland Plant List Indicator Rating Definitions* (Corps 2012). Listed from most likely to least likely to be found in wetlands, the indicator status categories are:

- **OBL** (obligate wetland) - occur almost always under natural conditions in wetlands.
- **FACW** (facultative wetland) - usually occur in wetlands, but occasionally found in non-wetlands.
- **FAC** (facultative) - equally likely to occur in wetlands or non-wetlands.
- **FACU** (facultative upland) - usually occur in non-wetlands, but occasionally found in wetlands.
- **UPL** (obligate upland) - occur almost always under natural conditions in non-wetlands.
- **NI** (no indicator) - insufficient data to assign to an indicator category.

APPENDIX B

WETLAND DETERMINATION DATA FORM

WETLAND DETERMINATION DATA FORM – Western Mountains, Valleys and Coast Region

Project/Site: 13th Street Gas Station City/County: Camas/Clark Sampling Date: 08/29/2023
 Applicant/Owner: PAK USA Camas, LLC State: WA Sampling Point: TP-1
 Investigator(s): J. Blake Section, Township, Range: S29, T2N, R3E
 Landform (hillslope, terrace, etc.): Floodplains Local relief: (concave, convex, none): Convex Slope (%): 0-3%
 Subregion (LRR): LRR MLRA2 Lat: 45.6318544 Long: -122.4669931 Datum: NAD83
 Soil Map Unit Name: Cove silty clay loam, thin solum, 0 to 3 percent slopes NWI classification: None

Are climatic / hydrologic conditions on the site typical for this time of year? Yes No (If no, explain Remarks.)
 Are Vegetation , Soil , or Hydrology significantly disturbed? Are "Normal Circumstances" present? Yes No
 Are Vegetation , Soil , or Hydrology naturally problematic? (If needed, explain any answers in Remarks.)

SUMMARY OF FINDINGS – Attach site map showing sampling point locations, transects, important features, etc.

Hydrophytic Vegetation Present? Yes <input checked="" type="checkbox"/> No <input type="checkbox"/> Hydric Soils Present? Yes <input type="checkbox"/> No <input checked="" type="checkbox"/> Wetland Hydrology Present? Yes <input type="checkbox"/> No <input checked="" type="checkbox"/>	Is the Sampled Area within a Wetland? Yes <input type="checkbox"/> No <input checked="" type="checkbox"/>
Remarks: TP-1 is located in the southwest corner of the site in an area with mapped hydric soils. TP-1 does not meet all three wetland indicators and is therefore in uplands. Hydrologic conditions were not typical for this time of year, as antecedent rainfall was determined to be drier than normal for the two months prior to the site visit.	

VEGETATION – Use scientific names of plants.

	Absolute % Cover	Dominant Species?	Indicator Status	Dominance Test Worksheet
Tree Stratum (Plot size: <u>30</u> ft radius)				Number of Dominant Species That Are OBL, FACW, or FAC: <u>5</u> (A) Total Number of Dominant Species Across All Strata: <u>6</u> (B) Percent of Dominant Species That Are OBL, FACW, or FAC: <u>83</u> (A/B)
1. <u>Malus spp.*</u>	20%	yes	FAC	
2. <u>Fraxinus latifolia</u>	20%	yes	FACW	
3. <u>Robinia pseudoacacia</u>	20%	yes	FACU	
4. <u>Crataegus monogyna</u>	15%	yes	FAC	Prevalence Index worksheet Total % Cover of: _____ Multiply by: _____ OBL species _____ x 1= _____ FACW species _____ x 2= _____ FAC species _____ x 3= _____ FACU species _____ x 4= _____ UPL species _____ x 5= _____ Column Totals: _____ (A) _____ (B) Prevalence Index = B/A= _____
50% = <u>38</u> 20% = <u>15</u>	75%	=Total Cover		
Sapling/Shrub Stratum (Plot size: <u>15</u> ft. radius)				
1. _____	%			
2. _____	%			
3. _____	%			
4. _____	%			
5. _____	%			
50% = _____ 20% = _____	%	=Total Cover		
Herb Stratum (Plot size: <u>5</u> ft radius)				Hydrophytic Vegetation Indicators: <input type="checkbox"/> 1 – Rapid Test for Hydrophytic Vegetation <input checked="" type="checkbox"/> 2 – Dominance Test is >50% <input type="checkbox"/> 3 - Prevalence Index is ≤3.0 ¹ <input type="checkbox"/> 4 - Morphological Adaptations ¹ (Provide supporting data in Remarks or on a separate sheet) <input type="checkbox"/> 5 - Wetland Non-Vascular Plants ¹ <input type="checkbox"/> Problematic Hydrophytic Vegetation ¹ (Explain)
1. <u>Festuca spp.*</u>	93%	yes	FAC	
2. <u>Iris spp.*</u>	5%	no	FACW	
3. <u>Rubus ursinus</u>	2%	no	FACU	
4. _____	%			
5. _____	%			
6. _____	%			
7. _____	%			
8. _____	%			
9. _____	%			
10. _____	%			
11. _____	%			
50% = <u>50</u> 20% = <u>20</u>	100%	=Total Cover		
Woody Vine Stratum (Plot size: <u>15</u> ft radius)				
1. <u>Rubus armeniacus</u>	5%	yes	FAC	
2. _____	%			
50% = <u>3</u> 20% = <u>1</u>	5%	=Total Cover		
% Bare Ground in Herb Stratum <u>0</u> %				
Hydrophytic Vegetation Present? Yes <input checked="" type="checkbox"/> No <input type="checkbox"/>				

Remarks: *Festuca spp.** and *Malus spp.** indicator statuses assumed FAC. *Iris spp.** indicator status assumed FACW.

SOIL

Sampling Point: TP-1

Profile Description: (Describe to the depth needed to document the indicator or confirm the absence of indicators.)

Depth (inches)	Matrix		Redox Features				Texture	Remarks
	Color (moist)	%	Color (moist)	%	Type ¹	Loc ²		
0-6	10YR 4/3	100%		%			Loam	
		%		%				
		%		%				
		%		%				
		%		%				
		%		%				
		%		%				
		%		%				

¹Type: C=Concentration, D=Depletion, RM=Reduced Matrix, CS=Covered or Coated Sand Grains. ²Location: PL=Pore Lining, M=Matrix

Hydric Soil Indicators: (Applicable to all LRRs, unless otherwise noted.)

- Histosal (A1)
- Histic Epipedon (A2)
- Black Histic (A3)
- Hydrogen Sulfide (A4)
- Depleted Below Dark Surface (A11)
- Thick Dark Surface (A12)
- Sandy Mucky Minerals (S1)
- Sandy Gleyed Matrix (S4)

- Sandy Redox (S5)
- Stripped Matrix (S6)
- Loamy Mucky Mineral (F1) **(except MLRA 1)**
- Loamy Gleyed Matrix (F2)
- Depleted Matrix (F3)
- Redox Dark Surface (F6)
- Depleted Dark Surface (F7)
- Redox Depressions (F8)

Indicators for Problematic Hydric Soils

- 2 cm Muck (A10)
- Red Parent Material (TF2)
- Very Shallow Dark Surface (TF12)
- Other (Explain in Remarks)

³Indicators of hydrophytic vegetation and Wetland hydrology must be present, unless disturbed or problematic

Restrictive Layer (if present):

Type: Hardpan
Depth (inches): 6

Hydric Soil Present? Yes No

Remarks:

HYDROLOGY

Wetland Hydrology Indicators:

Primary Indicators (min. of one required; check all that apply)

- Surface Water (A1)
- High Water Table (A2)
- Saturation (A3)
- Water Marks (B1)
- Sediment Deposits (B2)
- Drift Deposits (B3)
- Algal Mat or crust (B4)
- Iron Deposits (B5)
- Surface Soil Cracks (B6)
- Inundation Visible on Aerial Imagery (B7)
- Sparsely Vegetated Concave Surface (B8)

- Water-Stained Leaves (B9) **(except MLRA 1, 2, 4A, and 4B)**
- Salt Crust (B11)
- Aquatic Invertebrates (B13)
- Hydrogen Sulfide Odor (C1)
- Oxidized Rhizospheres along Living Roots (C3)
- Presence of Reduced Iron (C4)
- Recent Iron Reduction in Tilled Soils (C6)
- Stunted or Stressed Plants (D1) **(LRR A)**
- Other (Explain in Remarks)

Secondary Indicators (2 or more required)

- Water-Stained Leaves (B9) **(MLRA 1, 2, 4A, and 4B)**
- Drainage Patterns (B10)
- Dry-Season Water Table (C2)
- Saturation Visible on Aerial Imagery (C9)
- Geomorphic Position (D2)
- Shallow Aquitard (D3)
- FAC Neutral Test (D5)
- Raised Ant Mounds (D6) **(LRR A)**
- Frost-Heave Hummocks (D7)

Field Observations:

Surface Water Present? Yes No Depth (Inches): _____
 Water Table Present? Yes No Depth (Inches): _____
 Saturation Present? Yes No Depth (Inches): _____
 (Includes Capillary fringe)

Wetland Hydrology Present? Yes No

Describe Recorded Data (Stream gauge, monitoring well, aerial photos, previous inspections), if available:

Remarks: Hydrologic conditions were not typical for this time of year, as antecedent rainfall was determined to be drier than normal for the two months prior to the site visit.

APPENDIX C

PRECIPITATION INFORMATION

Antecedent Precipitation vs Normal Range based on NOAA's Daily Global Historical Climatology Network

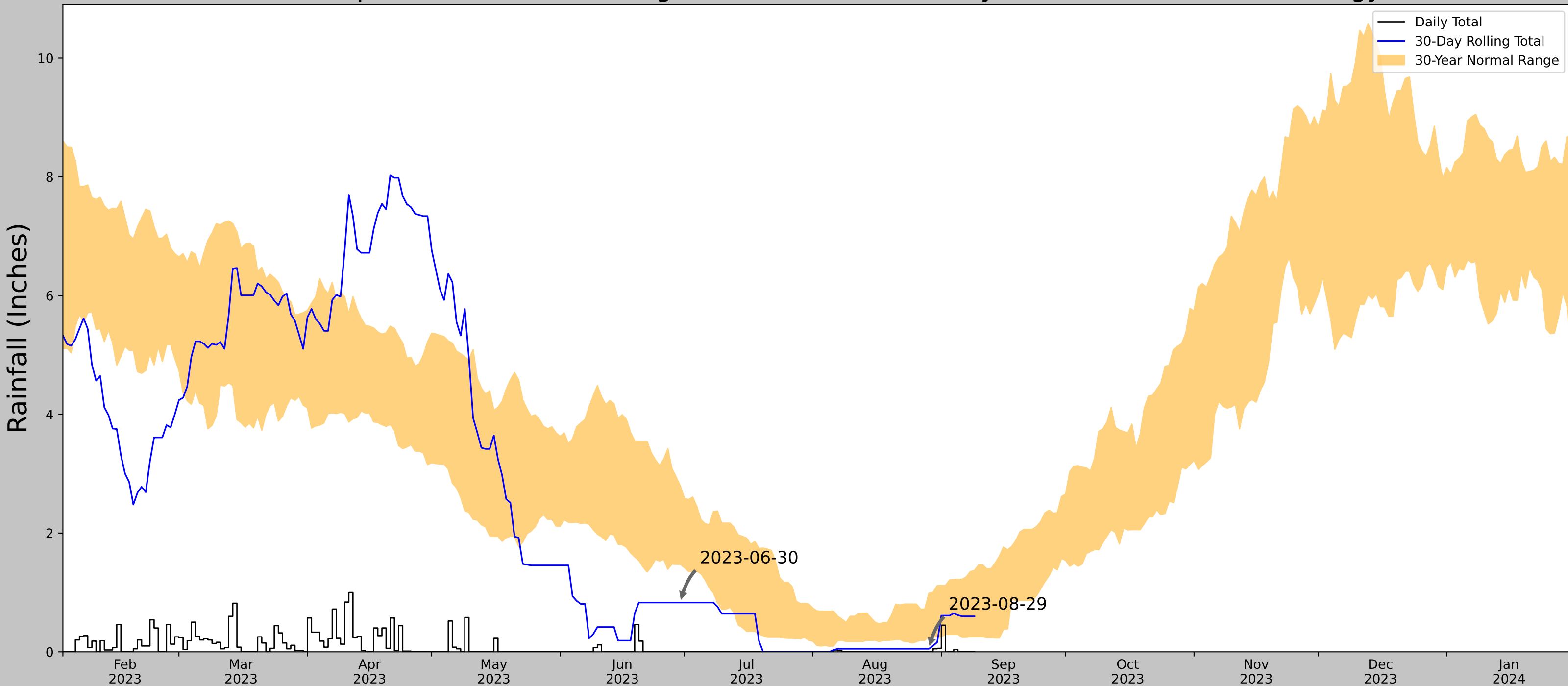

Coordinates	45.632018, -122.467297
Observation Date	2023-08-29
Elevation (ft)	253.44
Drought Index (PDSI)	Severe drought
WebWIMP H ₂ O Balance	Dry Season

30 Days Ending	30 th %ile (in)	70 th %ile (in)	Observed (in)	Wetness Condition	Condition Value	Month Weight	Product
2023-08-29	0.253543	0.986221	0.051181	Dry	1	3	3
2023-07-30	0.24252	0.814961	0.0	Dry	1	2	2
2023-06-30	1.475197	2.795276	0.830709	Dry	1	1	1
Result							Drier than Normal - 6



Figures and tables made by the
Antecedent Precipitation Tool
Version 2.0

Developed by:
U.S. Army Corps of Engineers and
U.S. Army Engineer Research and
Development Center



Weather Station Name	Coordinates	Elevation (ft)	Distance (mi)	Elevation Δ	Weighted Δ	Days Normal	Days Antecedent
BATTLE GROUND	45.7717, -122.5286	284.121	10.094	30.681	4.852	11318	69
BATTLE GROUND 0.8 N	45.794, -122.5443	316.929	1.716	32.808	0.828	0	1
BATTLE GROUND 1.2 NE	45.7958, -122.5275	361.877	1.666	77.756	0.879	0	20
VANCOUVER 4 NNE	45.6775, -122.6514	220.144	8.8	63.977	4.523	4	0
MERWIN DAM	45.955, -122.5625	224.081	12.769	60.04	6.513	31	0

SEPARATOR SHEET



OAK BANK USE PLAN

October 2, 2023



13th Street Gas Station
Camas, WA

Prepared for

PAK USA Camas, LLC
c/o Taz Khan
3993 NW Currawong Court
Camas, WA 98607
(512) 779-4999

Prepared by

Ecological Land Services

1157 3rd Avenue, Suite 220A • Longview, WA 98632
(360) 578-1371 • Project Number 3934.01

SIGNATURE PAGE

The information in this report was compiled and prepared under the supervision and direction of the undersigned.

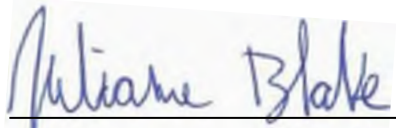
A handwritten signature in blue ink that reads "Julianne Blake". The signature is written in a cursive style and is positioned above a horizontal line.

Julianne Blake
Biologist III

TABLE OF CONTENTS

INTRODUCTION 1

RESPONSIBLE PARTIES..... 1

PROJECT DESCRIPTION 2

EXISTING CONDITIONS 2

 EXISTING AND SURROUNDING LAND USES 2

 EXISTING CRITICAL AREAS..... 2

AVOIDANCE AND MINIMIZATION 3

UNAVOIDABLE OREGON WHITE OAK IMPACTS 3

IMPACTED PRIORITY HABITAT FUNCTIONS 3

 HABITAT FUNCTIONS 3

OREGON WHITE OAK MITIGATION SELECTION RATIONALE 4

FUNCTIONS PROVIDED AT OAK BANK..... 5

 WILDLIFE HABITAT 5

ANTICIPATED FUNCTIONAL LIFT 5

PROPOSED MITIGATION CREDITS 5

CREDIT PURCHASE OR TRANSFER TIMING 6

CONFIRMATION OF MITIGATION CREDIT AVAILABILITY 6

LIMITATIONS 7

REFERENCES 8

TABLES (IN TEXT)

Table 1. Oak Summary..... 3

Table 2. Oak Impact Summary 3

Table 3. Credits for Oak Impacts at Terrace Oak Bank..... 6

FIGURES

- Figure 1 Vicinity Map
- Figure 2 Existing Conditions
- Figure 3 Proposed Conditions
- Figure 4 Terrace Oak Bank Service Area
- Figure 5 Terrace Oak Bank Site Design

INTRODUCTION

Ecological Land Services, Inc. (ELS) was contracted by PAK USA Camas, LLC to prepare this Oak Bank Use Plan to address Oregon white oak (oak) impacts resulting from the construction of a fuel station, convenience store, and associated parking lot. The site is approximately 0.97 acres and consists of Clark County Tax Parcel 176148000 located at 20101 NE 13th Street within the NW ¼ of Section 29, Township 2 North, and Range 3 East of the Willamette Meridian in Camas, Washington (Figure 1). Field work was conducted on August 29, 2023. The project will remove one existing oak (*Quercus garryana*) and impact 0.08 acres (3,456 square feet) of oak canopy. Canopy impacts will be offset by purchasing 0.238 credits from Terrace Oak Bank (Bank). This Bank Use Plan was prepared according to the *Camas Municipal Code (CMC) Title 16 Environment* (2023) and Washington Department of Fish and Wildlife’s (WDFW) *Management recommendations for Washington’s priority habitats: Oregon white oak woodlands* (1998).

RESPONSIBLE PARTIES

PROPERTY OWNER/APPLICANT

PAK USA Camas, LLC
Taz Khan
3993 NW Currawong Court
Camas, Washington 98607
(512) 779-4999
tkhanusa@gmail.com

PROJECT ENGINEER

PLS Engineering
Scott Gilliland
604 W Evergreen Boulevard
Vancouver, Washington 98660
(360) 944-6519
scott@plsengineering.com

MITIGATION BANK

Terrace Oak Bank, LLC
Cornell Rotschy
9210 NE 62nd Avenue
Vancouver, Washington 98665
(360) 334-3100
cornellr@rotschyinc.com

BIOLOGICAL CONSULTANT

Ecological Land Services, Inc.
Julianne Blake – Biologist III
1157 3rd Avenue, Suite 220A
Longview, Washington 98632
(360) 578-1371
Julianne@eco-land.com

PROJECT DESCRIPTION

The project area is approximately 0.97 acres and consists of Clark County Tax Parcel 176148000 located at 20101 NE 13th Street within the NW ¼ of Section 29, Township 2 North, and Range 3 East of the Willamette Meridian in Camas, Washington (Figure 1). The project consists of constructing a fuel station, convenience store, and associated parking lot. The parking lot will contain electric vehicle charging stations and vacuum pumps as well as pedestrian crossing areas (Figure 3). The existing oak will be removed as part of the project, removing 0.08 acres (3,546 square feet) of oak canopy. Canopy impacts will be mitigated by purchasing 0.238 credits from Terrace Oak Bank. Construction is anticipated to start upon receipt of all necessary permits.

Best management practices (BMPs) that will be completed prior to construction include designating staging and stockpile areas outside of critical areas and associated buffers, establishing a standard construction entrance, and installing silt fencing to prevent sedimentation. When site preparation is complete, construction will occur. A water truck will be available to prevent dust blowing during construction, if needed. Equipment used may include haul trucks, bulldozers, excavators, pavers, and hand tools. Upon completion of construction activities, disturbed areas that will not be paved will be seeded with a native grass seed mix.

EXISTING CONDITIONS

EXISTING AND SURROUNDING LAND USES

The 0.97-acre site consists of Clark County Tax Parcel 176148000 and is accessed by a paved driveway off NE 13th Street. The site is zoned as Business Park (BP) and currently contains a single-family mobile home, shed, carport, and paved driveway. The site is bordered to the north by NE 13th Street, to the east by NW Friberg-Strunk Street, to the south by undeveloped land and commercial development in progress, and to the west by undeveloped land and a single-family residence (Figure 2).

EXISTING CRITICAL AREAS

A site visit was completed by ELS in August 2023 following the appropriate technical manuals: *The Routine Determination Method according to the Corps of Engineers Wetland Delineation Manual* (Environmental Laboratory 1987) and the *Regional Supplement to the Corps of Engineers Wetland Delineation Manual: Western Mountains, Valleys, and Coast Region (Version 2.0)* (U.S. Army Corps of Engineers 2010). During the field visit, no wetlands were identified onsite (ELS 2023).

The WDFW Priority Habitats and Species online mapping tool depicts oak woodlands within the vicinity of the observed oak along the southern site boundary. One oak measuring approximately 52 inches diameter at breast height (DBH) was mapped along the southern site boundary during site reconnaissance (Figure 2). The oak has several live and dead branches, cavities, and has canopy connectivity with other trees in the vicinity but is not connected with other oaks. The oak location was mapped using a GPS system capable of submeter accuracy in ideal conditions. According to *CMC 16.61.010(3)(a)*, individual Oregon white oak trees with a twenty-inch DBH are considered a priority habitat.

Table 1. Oak Summary

Total Canopy Area	DBH	Number of Trunks	Noteworthy Habitat Features
0.08 acres 3,456 square feet	52 inches	1	<ul style="list-style-type: none"> • Canopy is interconnected with adjacent trees, but not other oaks • Two large cavities

AVOIDANCE AND MINIMIZATION

The preferred mitigation sequencing of first avoidance, then minimization, and finally compensation for unavoidable impacts was taken into consideration during the design process of this project; however, due to the single oak tree being located in an area of the site needed for a required driveway, avoiding Oregon white oak impacts altogether is not feasible. The Oregon white oak proposed for removal is the only oak tree onsite.

UNAVOIDABLE OREGON WHITE OAK IMPACTS

Removal of the oak will result in the loss of 0.08 acres (3,456 square feet) of Oregon white oak priority habitat as measured by the oak canopy coverage (drip line). The following table summarizes proposed oak impacts.

Table 2. Oak Impact Summary

Identifier	DBH	Canopy Coverage	Total Impact
Oregon White Oak (Single Mature Tree)	52 inches	0.08 acres 3,456 square feet	0.08 acres 3,456 square feet

IMPACTED PRIORITY HABITAT FUNCTIONS

ELS assessed the functions provided by the oak during a site visit on August 29, 2023. The functional assessment is based on Washington Department of Fish and Wildlife's (WDFW) *Management Recommendations for Washington's Priority Habitats, Oregon White Oak Woodlands* (Guidance) (Larsen and Morgan 1998).

HABITAT FUNCTIONS

Oak woodlands are considered "priority habitat and species" by WDFW and are protected locally by the City of Camas Municipal Code (CMC). According to *CMC 16.61.010(3)(a)*, individual Oregon white oak trees with a twenty-inch DBH are considered a priority habitat.

In urban or urbanizing areas west of the Cascades, WDFW defines priority oak habitat as single oaks, or stands of pure oak, or oak/conifer associations, 1 acre or greater in size. WDFW may also consider individual Oregon white oak trees a priority habitat when found to be particularly valuable to wildlife (i.e., contains many cavities, has a large DBH, is used by priority species, or has a large canopy) (Larsen and Morgan 1998). The project site is within the City of Camas (City). WDFW recommendation is that in urban and urbanizing areas, single trees should be maintained

if they are deemed important to species highly associated with Oregon white oak. Oaks and their associated flora comprise distinct woodland ecosystems with various plant communities providing valuable habitat that contributes to wildlife diversity. Oak woodlands provide a mix of feeding, resting, and breeding habitat for many wildlife species (Larsen and Morgan 1998).

The oak proposed for removal has several live and dead branches, cavities, and has canopy connectivity with other trees in the vicinity but is not connected with other oaks. Due to the placement of the oak within the City boundaries and lack of habitat connectivity, larger animals or those not adapted to urban conditions are not likely to be present. Therefore, removing the oak would likely result in habitat loss and a food source only for birds and small mammals that are well adapted to urban conditions.

OREGON WHITE OAK MITIGATION SELECTION RATIONALE

The Oregon white oak proposed for removal is located in the service area for the Terrace Oak Bank (Bank). The oak tree is approximately 4 miles southeast of the Bank, in the Lacamas Creek Watershed which is in the southeastern portion of the service area (Figure 4). The proposed oak removal will be mitigated by purchasing credits from the Bank at ratios specified in the Terrace Oak Bank's Mitigation Banking Instrument (MBI).

Rationale for selecting this mitigation bank is as follows:

- The oak onsite does not provide habitat for other priority species that should be replaced onsite. Habitat functions will be impacted for species common to urban areas, which can be fully replaced at the Bank.
- The habitat functions lost from the proposed oak removal correspond directly with the habitat creation purpose, goals, and objectives at the Bank which identifies 13.93 acres of existing Oregon white oak woodland WDFW Priority Habitat that will be restored to pre-agricultural conditions through creation, enhancement, and preservation. Creation and enhancement will be accomplished through planting oak saplings and/or native understory plantings, removing of Douglas-fir, and establishing a conservation easement over the entire 13.93 acres.

The 2008 *Compensatory Mitigation for Losses of Aquatic Resources, Final Rule* (Corps) recommends purchasing mitigation bank credits for ecological considerations (lower risk of failure and lower temporal loss of resources and services) and to avoid the maintenance and contingency issues and outright failures that often accompany permittee-responsible mitigation sites. Use of the Terrace Oak Bank substantially lowers the risk of failure and temporal loss of resource functions and services over newly established, permittee-responsible mitigation sites and offsite mitigation is anticipated to be more meaningful and beneficial to the watershed's habitat functions.

FUNCTIONS PROVIDED AT OAK BANK

The general goal of the Bank is to restore the approximately 13.93 acres to a state similar to its pre-agricultural condition through creation, enhancement, and preservation of an existing Oregon white oak woodland. All functions related to oak habitat are expected to increase as a result of design implementation. The primary ecological goals of the Bank are as follows:

- Removal of all existing impervious surfaces, including buildings, large equipment, gravel and paved areas, and debris, followed by replanting oak saplings and native understory species.
- Removal of invasive species in creation, enhancement, and preservation areas, primarily English ivy (*Hedera helix*) and Himalayan blackberry (*Rubus armeniacus*).
- Removal of Douglas-fir (*Pseudotsuga menziesii*) overstory as recommended by WDFW to reduce competition and further degradation of the Oregon white oak woodland from shading.
- Replanting of both creation and enhancement areas with oak saplings and native understory species to augment and expand existing Oregon white oak habitat.
- Preserve the Bank through a conservation easement.

WILDLIFE HABITAT

The proposed development site plan will provide diverse habitat for a variety of large and small mammals, songbirds, waterfowl, amphibians, and insects by improving the condition of the existing Oregon White Oak habitat through creation and enhancement that includes replanting of oaks and native understory, removing invasive species, non-native debris, and impervious surfaces, and eliminating Douglas-fir encroachment.

ANTICIPATED FUNCTIONAL LIFT

The creation, enhancement, and Douglas-fir stand release activities proposed in the Bank will provide a variety of benefits lifting overall habitat functions. Invasive species eradication and installing oak trees and native understory in open areas will increase the site's potential to provide habitat by providing improved and increased diversity of plant species, structure, and interspersed habitat. Removing Douglas-fir competition will allow the existing oaks to increase branching and smaller oak trees to become better established. The changes will increase acorn production, provide additional food for wildlife, and support a greater diversity of wildlife species as will removing impervious surfaces and debris. All functions impacted by removing an oak tree at the project site will be fully mitigated at the Bank.

PROPOSED MITIGATION CREDITS

As stated in the MBI (October 28th, 2020), the local jurisdiction with regulatory authority will determine both how impacts are measured¹ and the mitigation ratios required. The mitigation

¹ i.e., square foot of canopy area/root zone, DBH, etc.

credits required for impacts to Oregon white oak will be determined by using the local jurisdiction’s mitigation ratio (6:1) and multiplying this ratio by a “risk reduction factor” of 0.5. Impacts to high functioning Oregon White Oak Priority Habitat stands will be determined by the regulatory agencies on a case-by-case basis. Table 3 summarizes the impact type, mitigation ratio, and total credits proposed for compensation.

Table 3. Credits for Oak Impacts at Terrace Oak Bank

Impact Type	Impact Amount	Mitigation Ratio	Risk Reduction Multiplier	Mitigation Area Required	Proposed Credit Purchase
Canopy loss	0.08 acres (3,456 sq. ft.)	6:1	0.5	0.238 acres (10,368 sq. ft.)	0.238 credits

CREDIT PURCHASE OR TRANSFER TIMING

Following permit issuance, PAK USA Camas, LLC, as the applicant, will enter into a Buy/Sell Agreement with Terrace Oak Bank, for purchase of mitigation credits (in the quantity specified in Table 3) that would appropriately mitigate for the proposed project impacts. The actual purchase of credits will occur upon permit issuance. Prior to impacting the project oak, the applicant will submit proof of transfer of mitigation credits to project managers for the City of Camas. Proof of the mitigation transfer will be provided in the form of a notification letter to the approving agencies. Upon service of this notification, the mitigation requirement to purchase 0.238 mitigation credits will be fully satisfied.

CONFIRMATION OF MITIGATION CREDIT AVAILABILITY

Proof of the current number of available mitigation credits at the Terrace Oak Bank site will be confirmed by the approving agency, City of Camas and through the advising members of the Oak Bank Review Team.

Chair:

Brent Davis, Wetland and Habitat Review Program Manager
Clark County Community Development
P.O. Box 9810
Vancouver, WA 98666-9810
(360) 397-2375 ext. 4152
brent.davis@clark.wa.gov

Advisory Members:

Dave Howe, Area Habitat Biologist
Washington Department of Fish and Wildlife
5525 S 11th Street
Ridgefield, WA 98642
(360) 906-6729
david.howe@dfw.wa.gov

Carlo Abbruzzese, Pacific Cascade Region Natural Areas Manager
Washington Department of Natural Resources
2508 NW 126th Circle
Vancouver, WA 98685
(360) 577-2025
carlo.abbruzzese@dnr.wa.gov

LIMITATIONS

ELS bases this report's determinations on standard scientific methodology and best professional judgment. In our opinion, local, state, and federal regulatory agencies should agree with our determinations. However, the information contained in this report should be considered preliminary and used at your own risk until it has been approved in writing by the appropriate regulatory agencies. ELS is not responsible for the impacts of any changes in environmental standards, practices, or regulations after the date of this report.

REFERENCES

- City of Camas. 2023. *Camas Municipal Code (CMC) Title 16 Environment*. Camas, Washington. July 31, 2023.
- Ecological Land Services, Inc. (ELS). 2023. *Critical Areas Report for 13th Street Gas Station, Camas, Washington*. September 26, 2023.
- Ecological Land Services, Inc. (ELS). 2020. *Mitigation Banking Instrument for the Terrace Oak Bank, Clark County, Washington*. October 2020.
- Larsen, E. M., and J. T. Morgan. 1998. *Management recommendations for Washington's priority habitats: Oregon white oak woodlands*. Washington Department of Fish and Wildlife, Olympia. 37pp.
- Environmental Laboratory. 1987. *Corps of Engineers Wetlands Delineation Manual*, Technical Report Y-87-1. U.S. Army Corps of Engineer Waterways Experiment Station. Vicksburg, Mississippi.
- Interagency Review Team for Washington State. February 19, 2009. *Using Credits from Wetland Mitigation Banks: Guidance to Applicants on Submittal Contents for Bank Use Plans*. Online http://www.ecy.wa.gov/programs/sea/wetlands/mitigation/banking/pdf/mitig_plan_guidance.pdf. Accessed August 2023.
- U.S. Army Corps of Engineers (Corps). 2008. *Compensatory Mitigation for Losses of Aquatic Resources, Final Rule*. 33 C.F.R. §332, Federal Register, April 30, 2008.
- U.S. Army Corps of Engineers (Corps). 2010. *Final Regional Supplement to the Corps of Engineers Wetland Delineation Manual: Western Mountains, Valleys, and Coast Region (Version 2.0)*, ed. J.S. Wakeley, R.W. Lichvar, and C.V. Noble. ERDC/EL TR-08-13. Vicksburg, Mississippi: U.S. Army Engineer Research and Development Center.



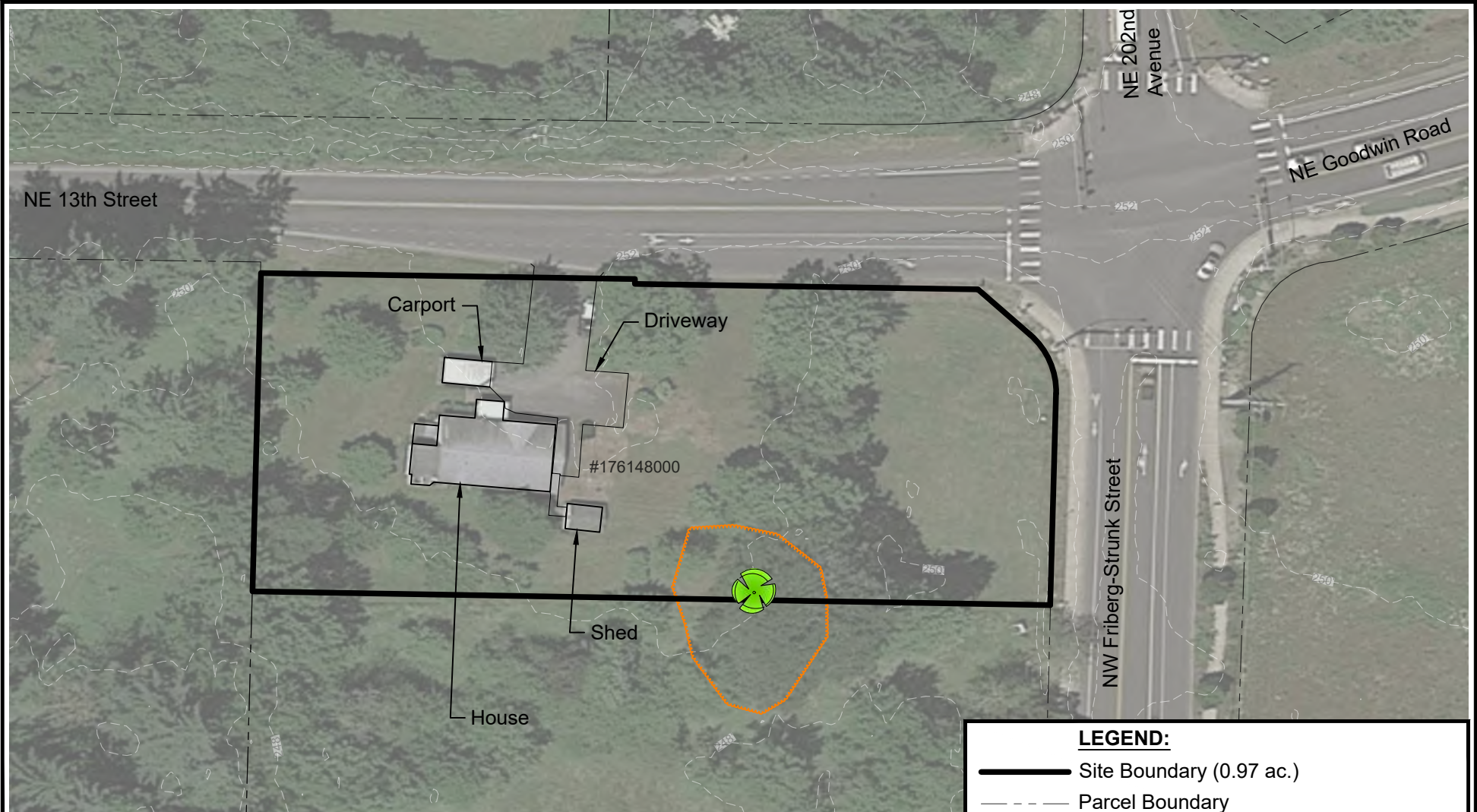

FIGURES



NOTE(S):

1. Aerial from Google Earth™ (6/17/2021).
2. Site boundary, oak tree location, and oak dripline surveyed by PLS Engineering, Inc.
3. Parcel data from Clark County GIS Department.
4. Topography from 2013 Clark County Lidar provided by WDNR at <https://lidarportal.dnr.wa.gov>.

LEGEND:

-  Site Boundary (0.97 ac.)
-  Parcel Boundary
-  Oregon White Oak Tree Location
-  Oak Dripline (0.08 ac. total/0.03 ac. onsite)
-  1' Contours

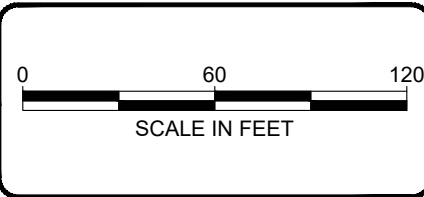
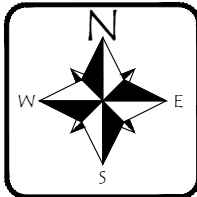

1157 3rd Ave., Suite 220A
Longview, WA 98632
Phone: (360) 578-1371
Fax: (360) 414-9305
www.eco-land.com

DATE: 9/29/23
DWN: JKJ
REQ. BY: JB
PRJ. MGR: JB
CHK:
PROJECT NO:
3934.01

Figure 2
EXISTING CONDITIONS
13th Street Gas Station
PAK USA Camas, LLC
City of Camas, Clark County, Washington
Section 29, Township 2N, Range 3E, W.M.

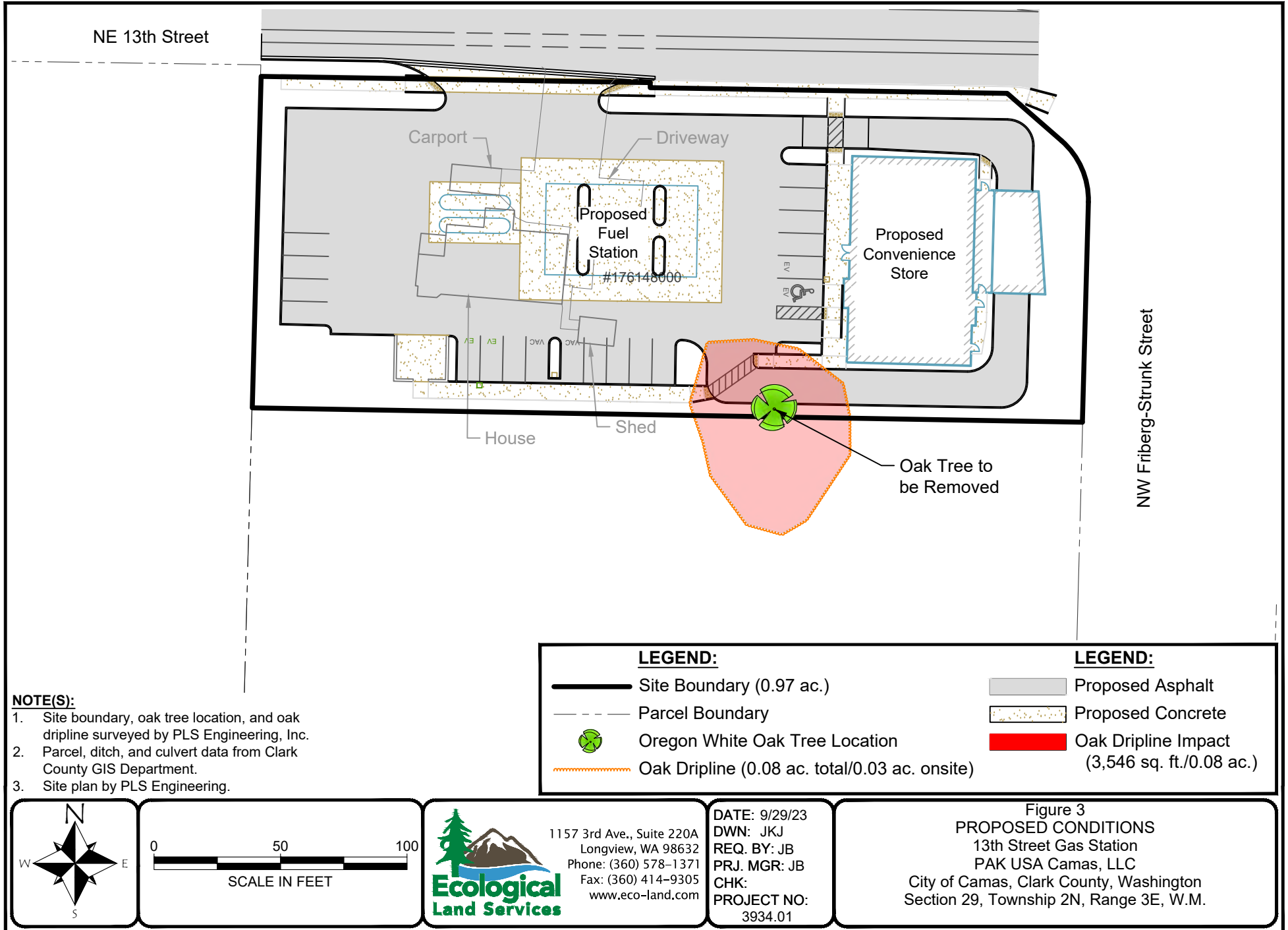

NOTE(S):

1. Site boundary, oak tree location, and oak dripline surveyed by PLS Engineering, Inc.
2. Parcel, ditch, and culvert data from Clark County GIS Department.
3. Site plan by PLS Engineering.

LEGEND:		LEGEND:	
	Site Boundary (0.97 ac.)		Proposed Asphalt
	Parcel Boundary		Proposed Concrete
	Oregon White Oak Tree Location		Oak Dripline Impact (3,546 sq. ft./0.08 ac.)
	Oak Dripline (0.08 ac. total/0.03 ac. onsite)		

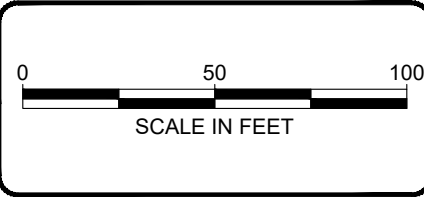

1157 3rd Ave., Suite 220A
 Longview, WA 98632
 Phone: (360) 578-1371
 Fax: (360) 414-9305
 www.eco-land.com

DATE: 9/29/23
 DWN: JKJ
 REQ. BY: JB
 PRJ. MGR: JB
 CHK:
 PROJECT NO:
 3934.01

Figure 3
 PROPOSED CONDITIONS
 13th Street Gas Station
 PAK USA Camas, LLC
 City of Camas, Clark County, Washington
 Section 29, Township 2N, Range 3E, W.M.

9/26/2023 4:06 PM C:\Users\Jennifer\Box\ELISWA\Clark\Camas\3934-PAK USA Camas, LLC\3934.01-13th St Feasibility\3934.01-Figures CAD Only\3934.01_OBSA.dwg Jennifer

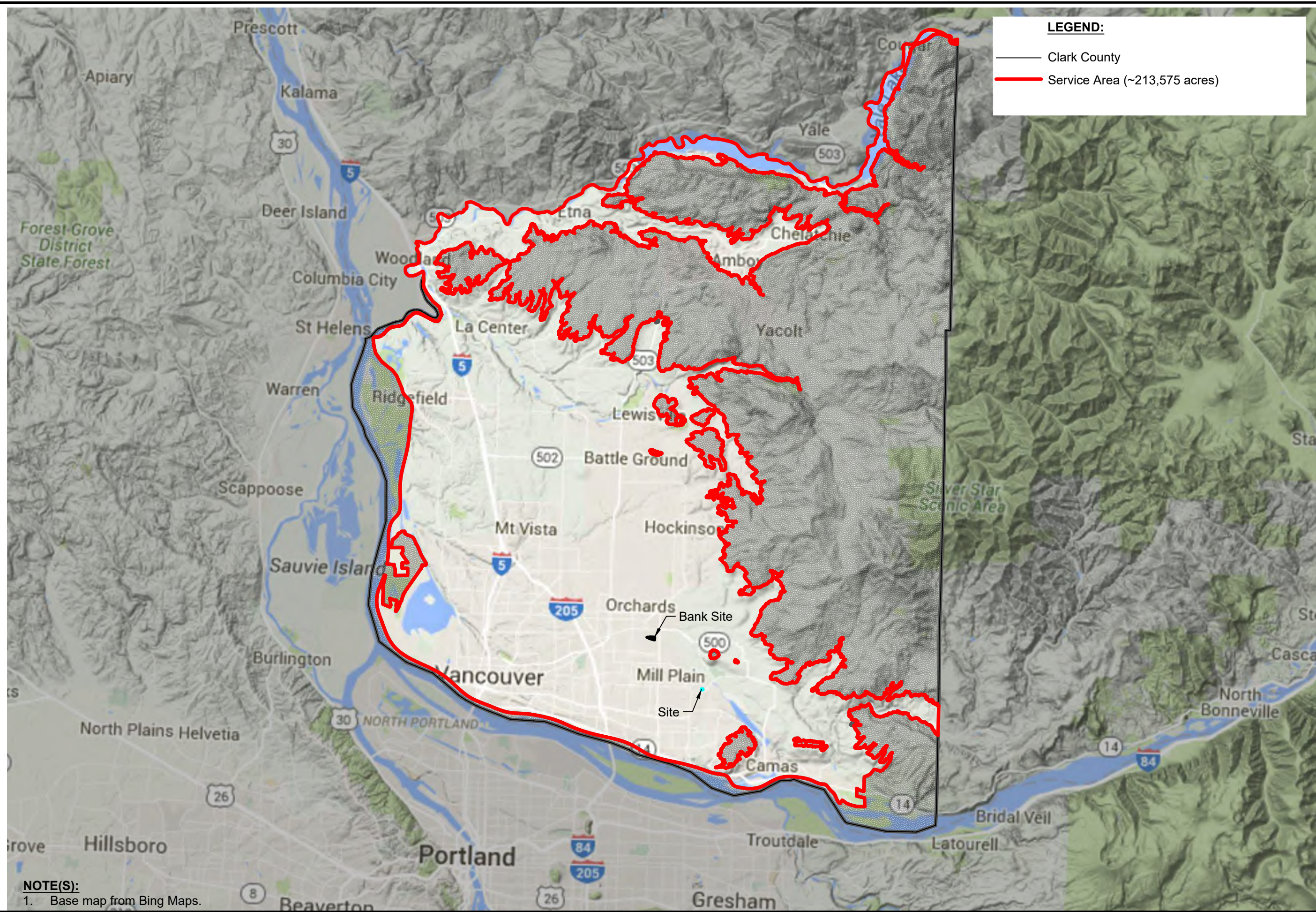

LEGEND:

- Clark County
- Service Area (~213,575 acres)

NOTE(S):
 1. Base map from Bing Maps.

Figure 4
TERRACE OAK BANK SERVICE AREA
 13th Street Gas Station
 PAK USA Camas, LLC
 City of Camas, Clark County, Washington
 Section 29, Township 2N, Range 3E, W.M.

DATE: 9/26/23
 DWN: JKJ
 REQ. BY: JB
 PRJ. MGR: JB
 CHK:
 PROJECT NO:
 3934.01

1157 3rd Ave., Suite 220A
 Longview, WA 98632
 Phone: (360) 578-1371
 Fax: (360) 414-9305
 www.eco-land.com

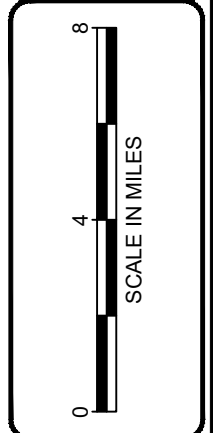

9/26/2023 4:06 PM C:\Users\Jennifer\Box\ELSWA\Clark\Camas\3934-PAK USA Camas, LLC\3934.01-13th St Feasibility\3934.01-Figures CAD Only\3934.01_OBSD.dwg Jennifer

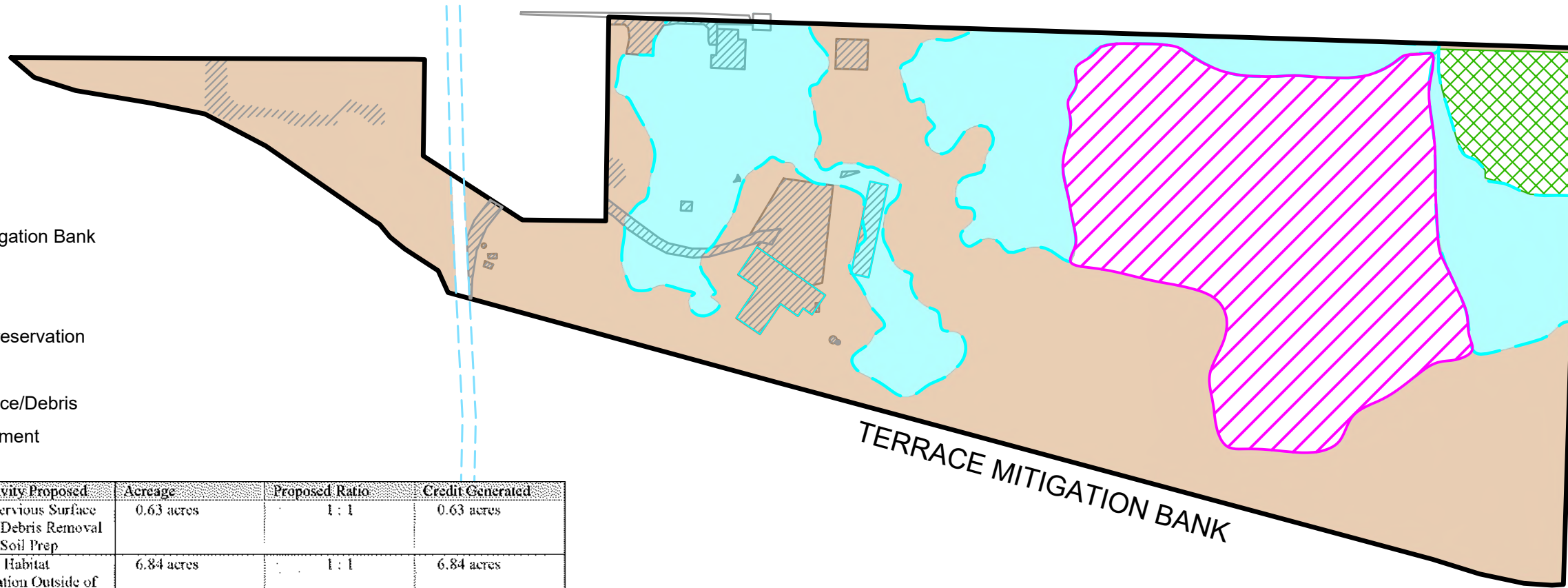

LEGEND:

- Terrace Oak Mitigation Bank
- Creation
- Enhancement
- ▨ Upland Forest Preservation
- ▨ Stand Release
- ▨ Impervious Surface/Debris
- Water Line Easement

Activity Proposed	Acreage	Proposed Ratio	Credit Generated
Impervious Surface and Debris Removal and Soil Prep	0.63 acres	1 : 1	0.63 acres
Oak Habitat Creation Outside of Existing Oak Stand	6.84 acres	1 : 1	6.84 acres
Douglas Fir Stand Release	3.34 acres	0.4 : 1	8.35 acres
Enhancement of Existing Oak Stand	3.20 acres	0.4 : 1	8.00 acres
Upland Forest Preservation	0.50 acres	0.5 : 1	1.00 acres
Totals	14.51 acres¹		24.82 acres

¹Total acreage includes areas of activity overlap and does not include 0.95 acres of water line easement, so is not reflective of the 13.93 acres represented in the legal survey of Oak Bank area.

Table 2. Oak Mitigation Bank Activity Descriptions.

Activity Proposed	Type of Activity/Area
Impervious Surface and Debris Removal and Soil Prep	<ul style="list-style-type: none"> • Includes: • Buildings, driveways, gravel pads or any other impervious area to be removed (regardless of whether oak tree canopy already covers the area) • Removal of debris piles throughout the site • Loosening of soils following impervious/debris removal
Oak Habitat Creation Outside of Existing Oak Stand	<ul style="list-style-type: none"> • Includes open areas of all types not currently covered by oak canopy • Areas to be replanted with oak saplings and native understory
Douglas Fir Stand Release	<ul style="list-style-type: none"> • Includes area of dense fir canopy within existing oak stand • Douglas fir over-story to be removed through harvest or tree girdling/snag creation
Enhancement of Existing Oak Stand	<ul style="list-style-type: none"> • Includes areas of existing oak canopy • Enhancement areas will have non-natives removed and understory planted with native shrubs typically associated with oak woodlands
Upland Forest Preservation	<ul style="list-style-type: none"> • Includes areas of deciduous forest adjacent to oak canopy, providing upland forest habitat • Area will be preserved through administration of a conservation easement

Figure 5
TERRACE OAK BANK SITE DESIGN
 13th Street Gas Station
 PAK USA Camas, LLC
 City of Camas, Clark County, Washington
 Section 29, Township 2N, Range 3E, W.M.

DATE: 9/26/23
 DWN: JKJ
 REQ. BY: JB
 PRJ. MGR: JB
 CHK:
 PROJECT NO:
 3934.01

1157 3rd Ave., Suite 220A
 Longview, WA 98632
 Phone: (360) 578-1371
 Fax: (360) 414-9305
 www.eco-land.com

