



## COOPERATIVE PURCHASE CUSTOMER AGREEMENT

This **Cooperative Purchase Customer Agreement ("Customer Agreement")** is entered into by and between Sam Pack's Five Star Ford ("**Vendor**") and the **City of Burleson, ("Customer" or "Authorized Customer")**, a Texas government entity, and a Customer authorized to purchase goods or services pursuant to the Agreement between the BuyBoard Cooperative Purchasing ("**Cooperative Entity**") and Vendor, **Contract No.** 724-23, as amended, (the "**Agreement**") with an expiration date of 11/30/2026.

This Customer Agreement includes and shall be governed by the following items which are attached hereto and/or incorporated herein by reference.

- i. The terms and conditions of the Agreement, which are incorporated herein by reference and available online or upon request from Vendor;
- ii. The City of Burleson Standard Terms and Conditions, which are incorporated herein by reference and available at **this link** or upon request from the Customer.
- iii. The attached Vendor Quote/Purchase Order, if applicable;
- iv. The Standard Addendum with the City of Burleson, if applicable

Authorized Customer is eligible and desires to purchase

### ATTACHMENT A

---

pursuant to the terms and conditions of the Agreement as the Cooperative Entity may specify from time to time, as well as the terms and conditions of this Customer Agreement. To ensure goods and services are provided directly to the Customer, the Cooperative Entity will only be responsible for services provided to the Cooperative Entity will not be responsible for payments for services provided to the Customer.

The Authorized Customer agrees to the terms and conditions of the Agreement as applicable and as authorized by law. The Authorized Customer hereby agrees that it is separately and solely liable for all obligations and payments for equipment, products and services provided hereunder. Vendor agrees that Customer shall be entitled to the same rights and protections under the law afforded to the Cooperative Entity under the Agreement, as applicable, as if Customer had entered into the Agreement. Except in the event of gross negligence or intentional misconduct, Customer's liability shall not exceed the amount paid by Customer under this Customer Agreement for the proceeding twelve (12) month period. Vendor agrees that until the expiration of three (3) years after final payment under this Customer Agreement, or the final conclusion of any audit commenced during the said three years, Customer, or Customer's designated representative, shall have access to and the right to audit at reasonable times, all records, hard copy or electronic, involving transactions relating to this Customer Agreement necessary to determine compliance herewith, at no additional cost to the Customer. Vendor agrees that the Customer shall have access to such records during normal business hours. Customer shall provide Vendor with reasonable advance notice of any intended audits.

**Purchase Price** - Payments under this Customer Agreement are in the amount of One hundred thirty-seven thousand fifty-nine dollars and forty-one cents ("**Purchase Price**").

**Term** - The Term of this Customer Agreement ("**Term**") shall be for one of the following as selected below (Select the type of contract that applies):

**Single Purchase Contract** -The Term shall not exceed one (1) year, unless acknowledged in writing by both parties, and this Customer Agreement shall be for the purchase of goods or services as specified and quoted by the Vendor, and the Purchase Price shall not exceed the budgeted amount for Customer's current fiscal year for the applicable goods and services.

**Supply / As Needed Contract**- The Term shall be effective as of October 1<sup>st</sup> and shall expire on September 30<sup>th</sup> at the end of FY. This Customer Agreement shall be for multiple purchases of goods or services on an as needed basis, from the same vendor under the same contract, and shall not exceed the budgeted amount for Customer's current fiscal year for the applicable goods and services.

**Multi-Year Contract**-The Term shall be for one (1) year(s) expiring on \_\_\_\_\_.  
This Customer Agreement may be renewed for two one- year renewals . Customer Agreement shall be with a single vendor for products and services. If the amount of expenditures under this Multi-Year Contract equals or exceeds \$50,000 in the aggregate, City Council approval is required. In the event the City does not appropriate sufficient funds to make payments during the current or any subsequent year, the City shall have the right to terminate this Multi-Year Contract at the end of any such fiscal year without penalty. If the price of any individual project under this contract exceeds \$50,000 a performance bond is required. If the individual project price exceeds \$100,000 both performance and payment bonds are required.

**Emergency Purchase** - Purchases that are necessary to address a public calamity, because of unforeseen damage to property, or to protect the public health or safety where the City's ability to serve the public would be impaired if the purchase were not made immediately. Emergency purchases must meet the requirements of Local Government Code 252.022, and must be ratified by City Council if the purchase is \$50,000 or more.

(Standard Addendum - Select if Vendor has additional terms and conditions that apply to this purchase)

**Standard Addendum with the City of Burleson, Texas** - If this purchase contains additional terms and conditions from the Vendor, other than those set forth in the Agreement, the Vendor shall agree to the Standard Addendum with the City of Burleson, Texas. Such applicable terms and conditions as set forth in the Standard Addendum shall supersede any conflicting terms of the Vendor's terms and conditions, and such Standard Addendum shall control. The Standard Addendum is incorporated herein by reference and **available online** or by request and made a part of this Customer Agreement for all purposes.

The undersigned represents and warrants that he/she has the power and authority to execute this Customer Agreement, bind the respective party, and that the execution and performance of this Customer Agreement has been duly authorized by the respective party. This Customer Agreement, and any amendment hereto, may be executed in counterparts, and electronically signed, scanned, digitally signed and sent via electronic mail and such signatures shall have the same effect as original manual signatures.

Each party has caused this Customer Agreement to be executed by its duly authorized representative on this the \_\_\_\_\_ day of \_\_\_\_\_ 20\_\_\_\_.

CITY OF BURLESON

By: \_\_\_\_\_

Name: \_\_\_\_\_

Title: \_\_\_\_\_

Date: \_\_\_\_\_

VENDOR: Sam Pack's Five Star Ford

DocuSigned By:   
By: \_\_\_\_\_  
5432D453E77C4A6...

Name: Alan Rosner

Title: Director

Date: 10/28/2024





Date: \_\_\_\_\_





# UTEM SKYTEL UTLI35B



-  Exclusive 540 degree boom rotation with hourglass worm gear drive  
Provides smooth and self locking rotation with a mechanical stop
-  Individual lever full pressure upper controls  
Full pressure single stick upper controls is optional
-  Outer boom is high strength steel, with fiberglass inner boom  
Non-lube bearings provided at pivot points
-  Non-tracking 30 in. insulation gap  
Insulation gap increases to 42 inches as boom is extended

Strength, innovation and service from UTEM



Utility Truck Equipment MFG, L.L.C.  
P.O. Box 9  
Hewitt, Texas 76643  
Phone: 254-857-8204 Fax: 254-857-9253  
WWW.UTEMBUCKETS.COM

# UTEM SKYTEL UTLI35B

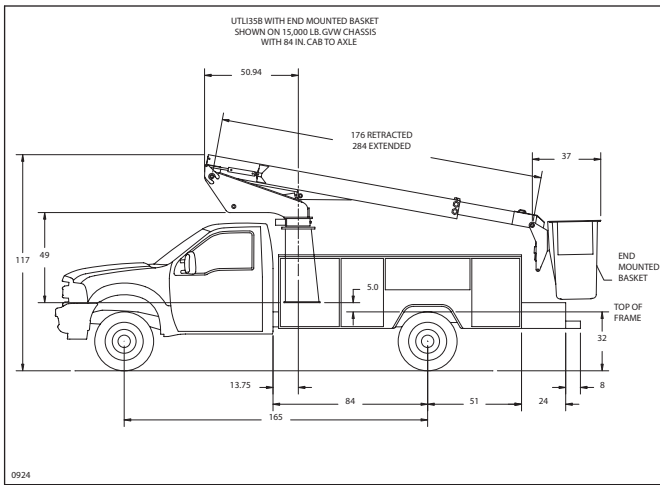

Dimensional Outline

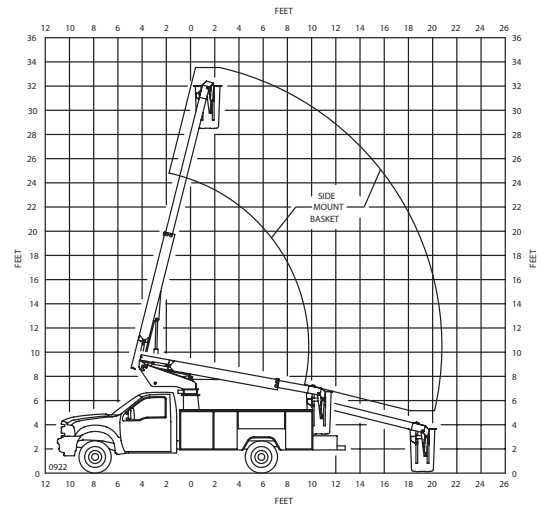

Operating Area Diagram

### Dimensional Specifications

	UTLI35B
Horizontal side reach - side mount	20 ft 9 in (6.32m)
Horizontal side reach - end mount	22 ft 9 in (6.93m)
Height to bottom of basket*	29 ft (8.83m)
Working height*	34 ft (10.36m)
Stowed height*	10 ft 1 in (3.07m)
Outer boom articulation in degrees	-14° to 76°
Standard basket capacity	300 lbs (136kg)
Maximum basket capacity	400 lbs (181kg)
UTLI non-tracking insulation gap is 30 in (0.76m)	
Tested and rated for Category D 46kV and below per ANSI A92.2-2015	
Meets or exceeds ANSI A92.2-2015 and OSHA requirements	
* Based on 36 in (0.91m) chassis frame height	

### Mechanical Specifications

- 540° Boom rotation with mechanical stop
- Rotation drive is hourglass worm gear acting on a shear ball bearing
- Hydraulic bucket leveling
- All hoses and controls cables are enclosed within the outer boom
- Boom elevation and extension by hydraulic cylinders
- Boom and extension cylinders have load holding valves
- Outer boom is high strength steel with infinitely adjustable wear pads
- Inner boom is filament wound oven cured epoxy resin fiberglass
- Pedestal is welded structure with reservoir mounted inside
- Standard color is UTEM white powder coat
- Body harness with adjustable length shock absorbing lanyard included

### Chassis Requirements

	Minimum	Recommended
Vehicle GVWR	10100 lbs	11000 lbs
Front axle GAWR	4000 lbs	4200 lbs
Rear axle GAWR	7500 lbs	7500 lbs
Frame section modulus	5.42 in <sup>3</sup>	5.42 in <sup>3</sup>
RBM of frame	195000 in lbs	195000 in lbs
Approx. weight for stability	7800 lbs	7800 lbs

### Controls

- Individual Lever Full Pressure Controls are Standard
- Leveling controls provided at upper and lower controls
- "HM" hydraulic system is provided with UTLI35B
- Engine stop/start provided with "HM" hydraulics
- Emergency stop is provided at basket controls
- Lower control override selector included

### Hydraulic Specifications

Operating pressure	2200 PSI (155kg/cm <sup>2</sup> )
Reservoir capacity with sight gauge	10 Gallons (38l)
Suction strainer mounted in reservoir	100 Mesh
Return line filter with bypass	10 Micron

### Optional Equipment

- Single stick upper controls
- Baskets with steps or walk thru openings with doors
- End mount basket
- Manual basket rotator
- Hydraulic basket rotator
- Continuous rotation
- Hydraulic tool outlet at basket
- Manual two-speed throttle
- 12VDC Powered Emergency Lowering
- Bridge mount pedestal and remote reservoir
- Outriggers for increased stability
- Outrigger/Boom interlock
- Torsion bars for increased stability



Utility Truck Equipment MFG, L.L.C.  
 PO Box 9  
 Hewitt, TX 76643

[WWW.UTEMBUCKETS.COM](http://WWW.UTEMBUCKETS.COM)

## **WARRANTY AERIAL LIFT**

A completed warranty registration must be returned to Utility Truck Equipment Mfg., LLC (UTEM) within ten (10) days after delivery of a UTEM Aerial Lift (The Product). The warranty registration is a part of the "Warranty Registration/Pre-Delivery Inspection" form that is provided with the product manuals. **UTEM is not obligated to warranty the unit unless this registration is on file.**

UTEM warrants The Product sold to be free from defects in material and workmanship under normal use and service for one (1) year after date of delivery to the initial user, subject to the following provisions:

- I. This warranty is limited to the repair or replacement of parts with appropriate labor as determined by UTEM upon inspection to have been defective in material or workmanship. There must be a warranty claim (supplied by UTEM) properly filled out and mailed to UTEM within thirty (30) days of the date of failure for approval and instructions regarding further disposition of parts. All parts have to be returned to the factory within thirty (30) days of the date of notification for UTEM inspection before credit can be given. Warranty parts shall be shipped to the factory pre-paid motor freight or UPS.
- II. Warranty with respect to batteries, generators, or optional equipment is subject to warranty offered by their respective manufacturer. Such warranties shall be handled direct through the respective manufacturer or their distributor.

UTEM Aerial Lifts are designed to be personnel carriers and have rated capacities for each unit. Exceeding the rated capacity or operating in a manner other than the intended use will void the warranty. These units are not designed to operate as cranes or pulling devices.

This warranty is in lieu of and excludes all other representations or warranties expressed or implied and does not apply where alterations or structural repair has been made to the "Product" without written authorization by UTEM. UTEM obligation under this warranty does not apply in case of any alterations, accidents, misuse, abuse, neglect or if maintained or operated in other manner than recommended or approved in the UTEM Operator's Manual.

**THERE IS NO WARRANTY OF MERCHANTABILITY OR FITNESS FOR ANY PARTICULAR PURPOSE NOR IS THERE ANY OTHER WARRANTY, EXPRESS OR IMPLIED, EXCEPT AS SPECIFICALLY STATED HEREIN. UTEM SHALL IN NO EVENT BE LIABLE FOR ANY SPECIAL, INDIRECT OR CONSEQUENTIAL DAMAGES OR CLAIMS OF ANY THIRD PARTY AGAINST CUSTOMER.**

## **IMPROVEMENTS**

UTEM reserves the right to make changes in design and improvements whenever it is believed the efficiency of the products will be improved, but without incurring any obligation to incorporate such improvements in any product which has been shipped or is in service.

**KNAPHEIDE**  
SINCE 1848

// FORD

# STEEL SERVICE BODIES

---

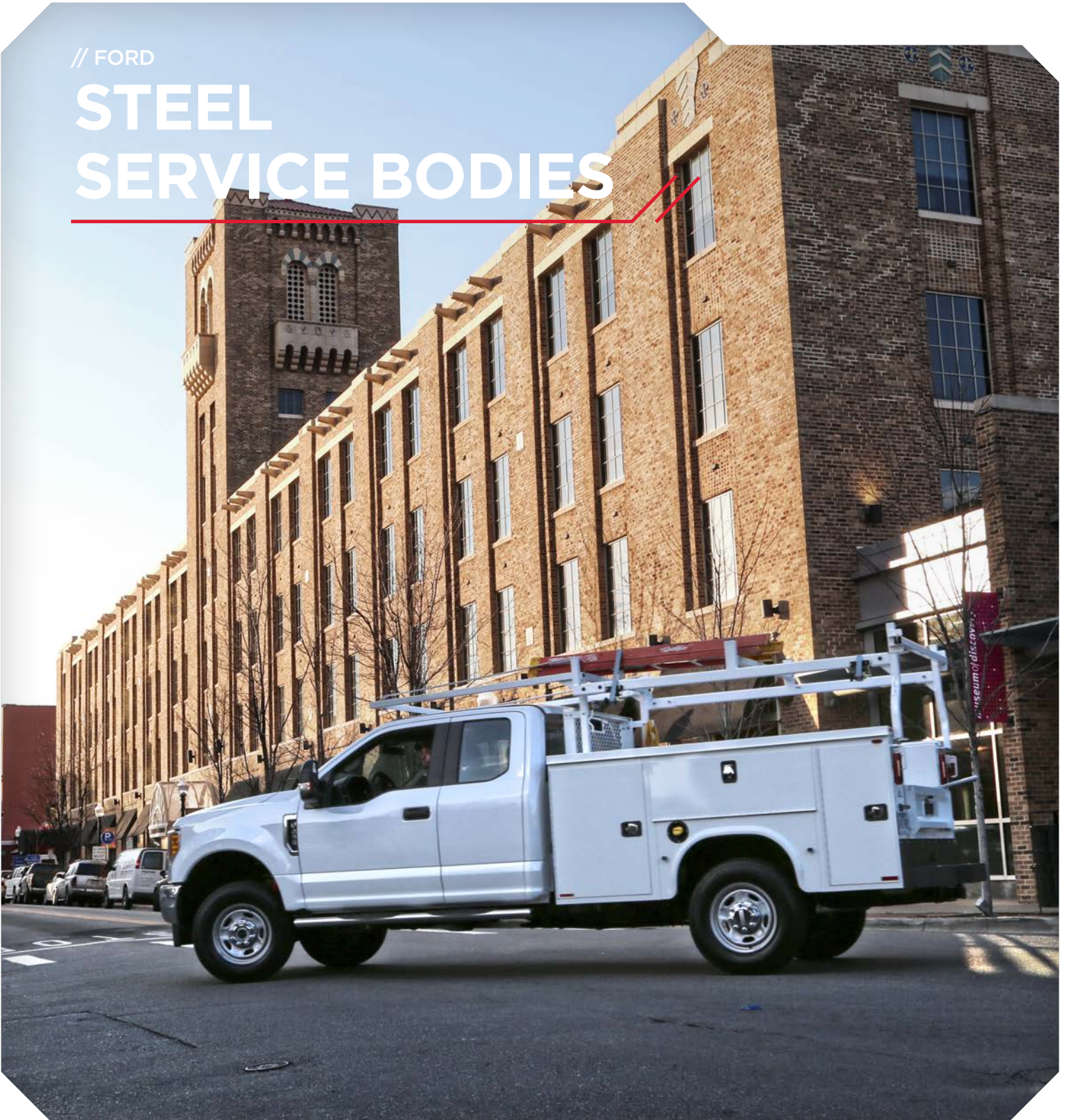



# STEEL SERVICE BODIES

With a rugged steel construction and external storage for your tools and equipment, the Service Body is a key component in your day-to-day productivity.

The external compartments offer protection from outside elements and allow technicians to access their equipment without having to climb into the truck bed.

Staying organized both on and between job sites is important. Get maximum efficiency with a Knapheide Service Body.



6108F40  
\*Body may be shown  
with optional features

## STANDARD SHELVING

All Knapheide Service Bodies come with the following standard shelving units:

- Two adjustable divider shelves and dividers, in the street and curb side front vertical compartments (1st and 2nd vertical 132" bodies only)
- One adjustable divider shelf and dividers in the street and curb side full height rear vertical compartments
- One adjustable divider shelf and dividers in the curb side horizontal compartment

REQUEST A QUOTE

Visit [knapheide.com/quote](http://knapheide.com/quote) and fill out the form to receive a quote and additional product information.

# STANDARD FEATURES

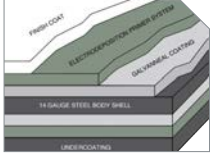

**A** Features 14-gauge, two-sided A-40 galvanized steel shell



**H** Features double-shell, 20-gauge, two-sided A-40 galvanized steel compartment doors

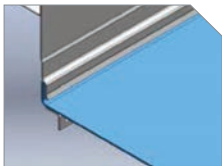

**B** Exclusive "Return Flange" floor design provides support

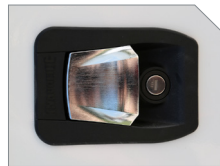

**I** Automotive-quality, rotary-style latches make opening and closing easy



**C** Interior light guards protect recessed lighting and wiring



**J** Interior cover protects internal latch from damage



**D** Continuous stainless steel hinges are pry-proof and corrosion-resistant

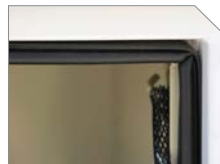

**K** Neoprene door seals protect compartments from the weather



**E** Adjustable security ring strikers provide a weather-tight seal



**L** Quick-mount installation allows for fast, safe mounting



**F** Includes 250-lb. capacity adjustable divider shelves



**M** Includes slam-lock tailgate with one-hand center release



**G** Double-spring over-center door retainer eliminates involuntary door swing



**N** Upgraded surface mount lighting system features LED S/T/T and B/U, LED strobe option\* with (8) selectable patterns, and built-in reflectivity for additional safety\*\*

\*Additional wire harness required for strobe lights  
\*\*Covered under 3-year limited warranty

## // E-COAT PROTECTION:

Electrodeposition prime-paint system provides superior corrosion resistance

# COMPARTMENT CONFIGURATIONS



## // 500 SERIES COMPARTMENTS

The 500 Series Service Bodies feature a horizontal compartment that stretches from the first vertical compartment to the end of the body with a small, rear lower compartment.



## // 600 SERIES COMPARTMENTS

The 600 Series Service Bodies feature a horizontal compartment that is positioned over the wheel well and one vertical compartment in the front of the body and one at the rear of the body.

## // 700 SERIES COMPARTMENTS

The 700 Series has 500 Series configuration on the curb side and 600 Series on the street side.

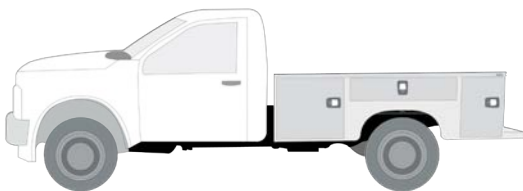

## // LOW PROFILE BODY

Low Profile Bodies, denoted by “LP”, offer greater visibility from the cab while only sacrificing 4” of the body height compared to a standard Service Body.

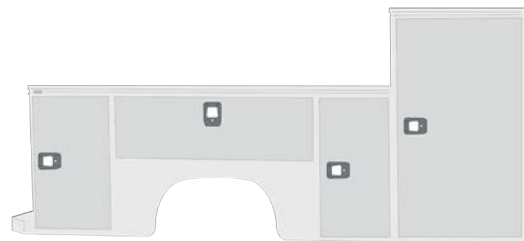

## // RAISED FRONT COMPARTMENTS

Raised front vertical compartment configuration raises the curb side front vertical compartment to 60” tall.



## // **FLIP TOP** COMPARTMENTS

Flip Tops, denoted by “F”, allow for greater internal storage, organization and flexibility. Knapheide Flip Tops have a slammable top lid door and a convenient one-hand release located in the horizontal compartment.



## // **PLUS 50** COMPARTMENTS

Plus 50 models feature a transverse compartment in the curb side front vertical extending to the street side compartment back. Plus 50 models have 50% more effective storage capacity.

Depending on body model, compartments have either two or three drawers, 59” or 69” long. All drawers are rated for 250-lb. and have dividers every 4”.

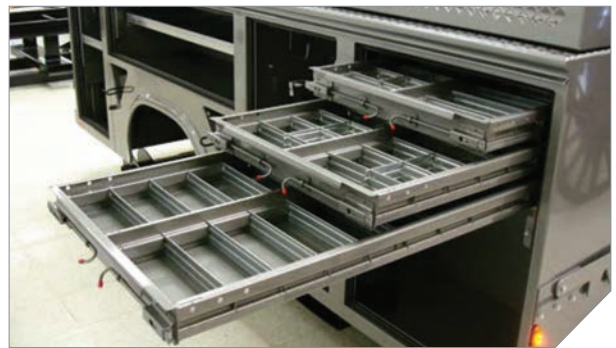

**THREE-DRAWER UNIT**



**TWO-DRAWER UNIT**

# POPULAR OPTIONS

## // BUMPERS

Knapheide bumpers are constructed with work in mind. With three configurations, we have a bumper for every need. Select bumpers available with KnapLiner coating for additional grip and durability.



**STEP BUMPERS**



**HITCH RECESS BUMPERS**



**STRAIGHT BUMPERS**

## // CANOPY ROOF

The canopy roof option allows you to fully enclose your cargo area. Canopy roofs are available in three heights, straight sides, and with stationary or telescopic roofs. For a tapered-side one-piece body design, take a look at our KUVcc product line.

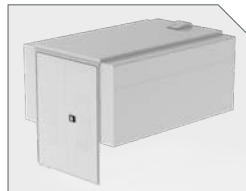

**STRAIGHT SIDES**

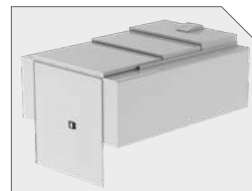

**TELESCOPIC ROOF**

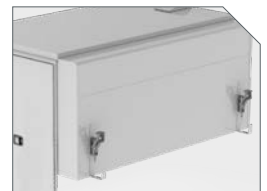

**SIDE LADDER RACKS**

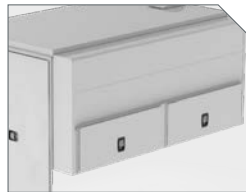

**SIDE ACCESS DOORS**



**REAR ACCESS DOOR**

## // RACKS

Adding a rack to your Service Body increases your storage space by getting your ladders and other long tools or equipment up and out of the way, making room to haul more items in your cargo area.



**OVERCAB MATERIAL RACK**  
(KARGO MASTER)



**SIDE MOUNT LADDER RACK**



**OVERHEAD LADDER RACK**



**KNAPHEIDE UTILITY RACK**

NOT PICTURED (APPLIES TO SIDE MOUNT & OVERHEAD LADDER RACKS):

- LADDER RACK ROLLERS

- LADDER RACK RAILS

## // TELESCOPIC SLIDING ROOF

Telescopic sliding roofs offer a robust enclosure for the cargo space of your Service Body, allowing you to protect your tools and equipment from theft and weather.



## // CRANE REINFORCEMENT KIT

The crane reinforcement kit option allows you to incorporate a crane up to 4,000 lb. capacity (16,000 ft-lb. max.) onto the rear curb side corner of your body.

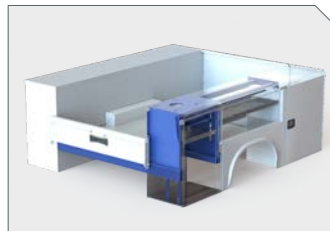

## // SERVICE BODY PACKAGES

Need your work truck fast? These preconfigured packages are built for quicker delivery to you. Ask your Knapheide rep for more information.

### 1848 PACKAGE

- Painted white
- Lights installed and wired
- Power locks installed
- LED compartment lights installed
- Sortimo BOXX package in left horizontal compartment
- Aluminum tread plate rock guards and tailgate trim installed

### PIONEER PACKAGE

- Painted white
- Lights installed and wired
- Masterlocks installed
- Aluminum tread plate rock guards installed
- Aluminum tread plate trim kit installed: includes tops of compartments and tailgate

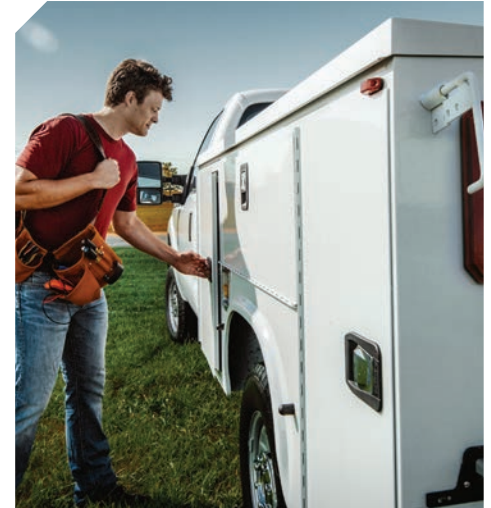

## COMMITMENT TO CORROSION RESISTANCE

Corrosion won't be a concern when you buy quality Knapheide products.

To give you the best corrosion protection on our steel bodies, we utilize a state-of-the-art, custom-designed, 12-step, SST cathodic electrodeposition finishing system, called "E-Coat."

It bonds prime paint to steel by an electroplating process to give you a superior coat of primer, resulting in better corrosion protection compared to spraying methods.



**MASTER LOCKS**



**POWER LOCKS**



**FRONT STROBE**



**LED  
COMPARTMENT  
LIGHTS**



**GRAB HANDLES**



**E-TRACK &  
ACCESSORIES**



**ALUMINUM  
DRAWERS**



**STEEL DRAWERS**



**FLEX STEPS**



**WHEEL CHOCK  
HOLDER -  
FENDER SKIRT**



**SORTIMO  
COMPARTMENT  
STORAGE/MOBILITY**



**ROCK GUARDS**



**ALUMINUM TREAD  
PLATE TRIM KITS**



**MODULAR CAB  
GUARD**



**PULL-OUT TRAY**



**PULL-OUT  
SHELVES**

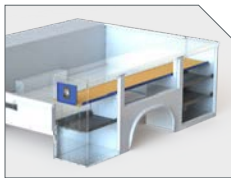

**REAR ACCESS  
DOOR WITH OR  
WITHOUT FULL-  
LENGTH SHELF**



**SINGLE POINT  
OR THREE POINT  
T-HANDLE**



**BOTTLE GAS  
RETAINER**



**CARGO  
TIE-DOWNS**

## // 40" CA SINGLE REAR WHEEL

MODEL	TYPE	HEIGHT	WEIGHT
680	Standard	40"	964 lb.
680LP	Low Profile	36"	904 lb.
680F	Flip Top (L)	37.25"	1,009 lb.
680F40	Flip Top (H)	41.25"	1,069 lb.

TRUCK	CAB	GVWR
X2A/X2B	Super	9,900/10,000 lb.
W2A/W2B	Crew	9,900/10,000 lb.
X3A/X3B	Super	10,000/11,500 lb.
W3A/W3B	Crew	10,000/11,500 lb.

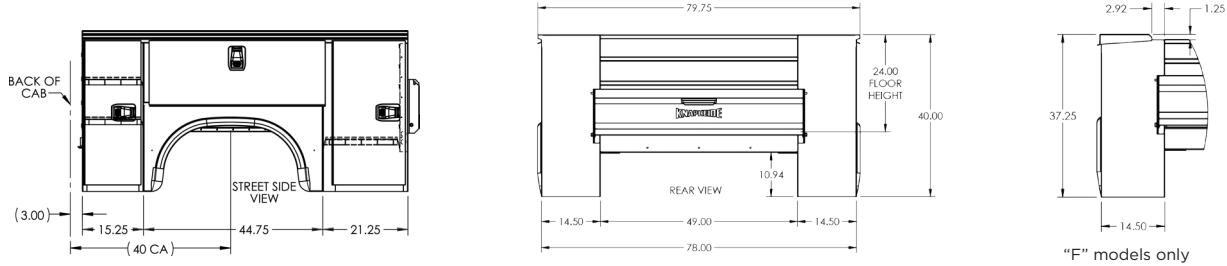

## // 56" CA SINGLE REAR WHEEL

MODEL	TYPE	HEIGHT	WEIGHT
696	Standard	40"	1,111 lb.
696LP	Low Profile	36"	1,060 lb.
696F	Flip Top (L)	37.25"	1,183 lb.
696F40	Flip Top (H)	41.25"	1,234 lb.
696D38*	Standard	40"	1,153 lb.
696D38LP*	Low Profile	36"	1,100 lb.
696D38F*	Flip Top (L)	37.25"	1,223 lb.

TRUCK	CAB	GVWR
F2A/F2B	Regular, Gas	9,900/10,000 lb.
X2A/X2B	Super	9,900/10,000 lb.
W2A/W2B	Crew	9,900/10,000 lb.
F3A/F3B	Regular, Gas	10,000/11,500 lb.
X3A/X3B	Super	10,000/11,500 lb.
W3A/W3B	Crew	10,000/11,500 lb.

\*D38 models denote 38" wide floor and 20" deep compartments

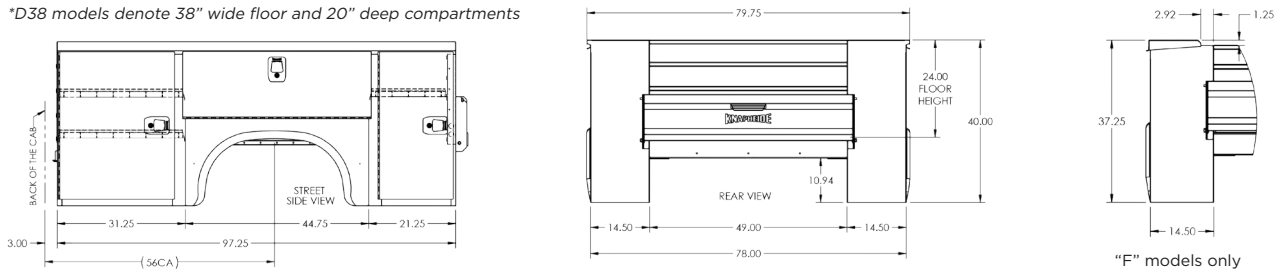

## // 56" CA DUAL REAR WHEEL

MODEL	TYPE	HEIGHT	WEIGHT
696D54	Standard	40"	1,288 lb.
696D54LP	Low Profile	36"	1,234 lb.
696D54F	Flip Top (L)	37.25"	1,357 lb.
696D54F40	Flip Top (H)	41.25"	1,412 lb.

TRUCK	CAB	GVWR
F3C/F3D	Regular	13,000/14,000 lb.
X3C/X3D	Super	13,000/14,000 lb.
W3C/W3D	Crew	13,000/14,000 lb.

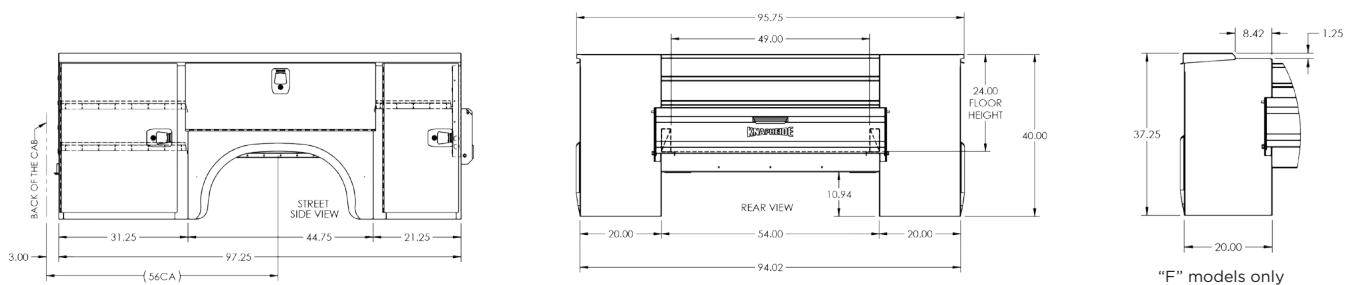



## // 60" CA SINGLE REAR WHEEL

MODEL	TYPE	HEIGHT	WEIGHT
6108	Standard	40"	1,238 lb.
6108LP	Low Profile	36"	1,176 lb.
6108F	Flip Top (L)	37.25"	1,311 lb.
6108F40	Flip Top (H)	41.25"	1,374 lb.

TRUCK	CAB	GVWR
F3E/F3F	Regular	9,800/11,500 lb.
X3E/X3F	Super, Gas	9,800/11,500 lb.
W3E/W3F	Crew, Gas	9,800/11,500 lb.

Note: Chassis with GVWRR 10,000 lb. and under subject to curb weight limits.  
 Not all engine/drive and body combinations are applicable.

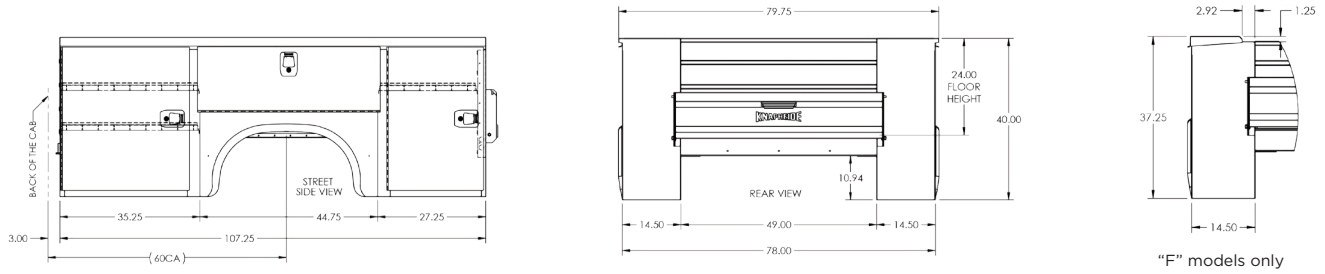

## // 60" CA DUAL REAR WHEEL

MODEL	TYPE	HEIGHT	WEIGHT
6108D54	Standard	40"	1,399 lb.
6108D54LP	Low Profile	36"	1,366 lb.
6108D54F	Flip Top (L)	37.25"	1,471 lb.
6108D54F40	Flip Top (H)	41.25"	1,530 lb.

TRUCK	CAB	GVWR
F3G/F3H	Regular	14,000 lb.
X3G/X3H	Super	14,000 lb.
W3G/W3H	Crew	14,000 lb.
F4G/F4H	Regular	15,000/16,500 lb.
X4G/X4H	Super	15,000/16,500 lb.
W4G/W4H	Crew	15,000/16,500 lb.
F5G/X5H	Regular	17,500/19,500 lb.
X5G/X5H	Super	17,500/19,500 lb.
W5G/W5H	Crew	17,500/19,500 lb.

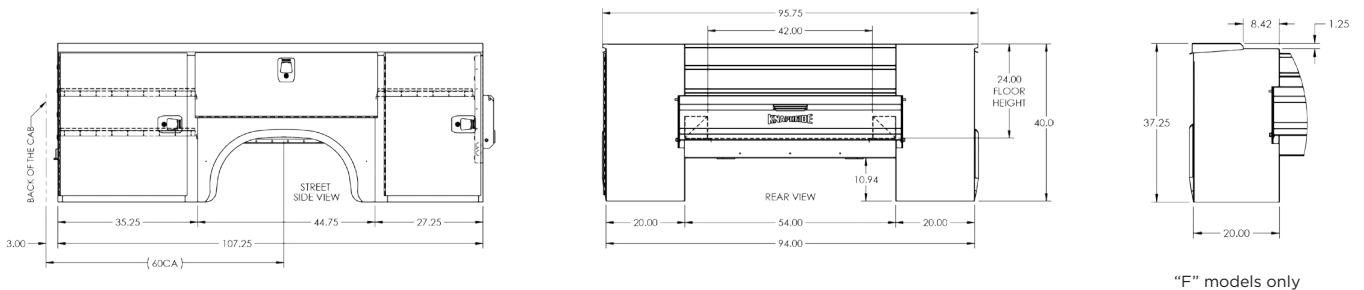

# // 82" CA SINGLE REAR WHEEL - FORD TRANSIT

MODEL	TYPE	HEIGHT	WEIGHT
6129-FT	Standard	43"	1,448 lb.

TRUCK	CAB	GVWR
R5Z	Regular	9,000 lb.
W5Z	Regular	9,500 lb.

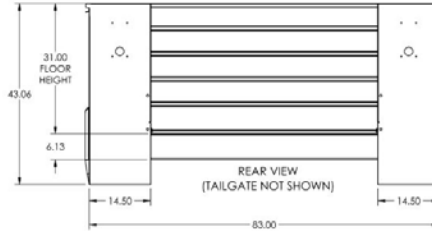
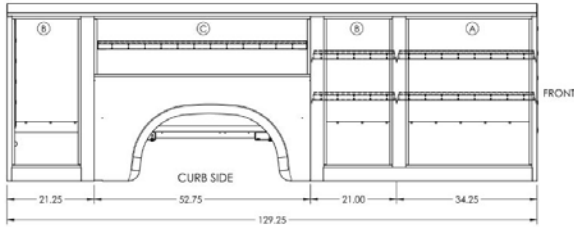

# // 84" CA DUAL REAR WHEEL

MODEL	TYPE	HEIGHT	WEIGHT
6132D54	Standard	40"	1,704 lb.
6132D54LP	Low Profile	36"	1,626 lb.
6132D54F	Flip Top (L)	37.25"	1,791 lb.
6132D54F40	Flip Top (H)	41.25"	1,863 lb.

TRUCK	CAB	GVWR
F3G/F3H	Regular	14,000 lb.
F4G/F4H	Regular	15,000/16,500 lb.
X4G/X4H	Super	15,000/16,500 lb.
W4G/W4H	Crew	15,000/16,500 lb.
F5G/F5H	Regular	17,500/19,500 lb.
X5G/X5H	Super	17,500/19,500 lb.
W5G/W5H	Crew	17,500/19,500 lb.

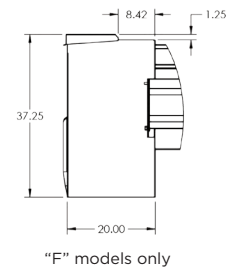
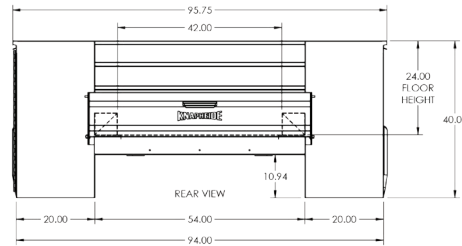
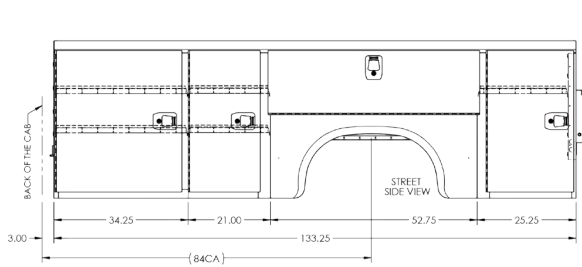

# NEVER SETTLE

If you are going to be a leader, it takes more than building a high-quality product. It means never being totally satisfied with that product, no matter how high quality it may be. It requires constant vigilance and a willingness to take a chance on something new. And it means exceeding expectations every time. As the industry changes, one thing never will—our commitment to making customers like you as productive and efficient as possible. We know you don't settle, and we don't either. That's why we want you never to settle for anything less than Knapheide on the back of your truck.

**Knapheide. Never settle.**

## SIX-YEAR, LIMITED WARRANTY

STEEL SERVICE BODIES



NO RUST THROUGH



DOOR HINGES WILL NOT FAIL OR COME OFF BODY



LATCHES AND LOCK CYLINDERS WILL NOT FAIL TO OPERATE



SHELVES WILL NOT BEND UNDER MAX. LOAD OF 250 LBS.

Visit [www.knapheide.com/warranty](http://www.knapheide.com/warranty) for more information.



The Knapheide Manufacturing Company  
1848 Westphalia Strasse | Quincy, IL 62305

217-222-7131  
[www.knapheide.com](http://www.knapheide.com)

**KNAPHEIDE**  
SINCE 1848

## UTILITY TRUCK EQUIPMENT COMPANY

POST OFFICE BOX 9, HEWITT, TEXAS 76643

821 ENTERPRISE, HEWITT, TEXAS 76643

PH: 254-857-8813 FAX: 254-857-9253

**15-Oct-24**

**CONTACT** Alan Rosner  
**COMPANY** Sam Packs Five Star Ford  
**PHONE** 214-837-3054  
**EMAIL** [alanr@spfrod.com](mailto:alanr@spfrod.com)

**QUOTE #** 53613UTLI35B\_CityOfBurlesonSamPacksAlanRosner

<u>Part Number</u>	<u>Qty</u>	<u>Product Description</u>	<u>Price</u>
UTLI35B	1	UTEM UTLI35B Insulated, Full-Pressure, Telescopic Aerial Device	----
701140	1	Truck Mount Pedestal	----
701141	1	Turret, Stowed Height of 10 ft. 1 in. (3.07m)	----
701255	1	Fiberglass Boom with Hydraulic Leveling	----
701098	1	Hydraulic Rotator for End Mounted Platforms	----
701431	1	Single Stick Control with End Mount Platform	----
701523	1	"HM" Hydraulics	----
701261	1	Manual 5-Spool Control Valve	----
701142	1	540 Degree Non-Continuous Rotation	----
702810	1	2017 & Later Ford Chassis Pedestal Mount (Without Outriggers)	----
700535	1	350lb. (159kg) Platform Capacity	----
501070	1	24x24x42 Fiberglass Basket W/ Center Walk Thru & Door	----
426551	1	Soft Vinyl Basket Cover (Fits 24x24 Basket)	----
701054	1	Emergency Lowering with "HM" Hydraulics	----
500600	1	UTEM White Powder Coat	----
501118	1	Electrical Certification to 46kV and Below For Category D	----

**ALL PRICES F.O.B. HEWITT, TEXAS**

*\*Two complete sets of manuals and one safety harness and lanyard are provided with each unit.*

*\*Quote Good For 30 Days*

*\*Aerial Compliant W/ ANSI Standard A92.2-2015*

**Knapheide Service Body Model# 6132D54-2-M**

Mounts on 84"CA Ford DRW Chassis

132"L x 94"W

54"W Loadspace

20"D Compartments

40"T Side Packs

Includes Ford Mounting Kit

Includes LED Light Kit

Includes Standard Shelving

Includes Master Lock System

Includes Knapheide White Paint

**Installation**

Install Aerial Mounting Hardware On Chassis Frame

Install Rear Underframe Torsion Bar For Ford F550

Prep & Install Knapheide Service Body

Install UTEM Aerial Model# UTLI35B

Fabricate & Install Boom Rest

Install PTO & Pump For Ford F550 Diesel

Wire PTO For Start/Stop

Wire Body DOT Light Kit

Fabricate & Install Tailshelf W/ Side Access Steps  
Fabricate & Install ICC Bumper  
Fabricate & Install Arch Type Grab Handle  
Install Chrome Grab Handle On Rear Of Side Pack  
Install Bucket Support Tube On Tailshelf Surface  
Fabricate & Install ICC Towing Package  
Includes (Qty 2) 1/2" D-Rings  
Includes 7-Way Trailer Plug  
Includes Electronic Brake Controller W/ Ford Wiring Harness  
Includes Receiver Tube  
(Qty 2) Ecco Amber Surface Mounted Strobes (One Driverside Front Grill/One Passenger Side Tailshelf  
(Qty 2) Ecco Blue Surface Mounted Strobes (One Passenger Side Front Grill/One Driver Side Tailshelf  
(Qty 2) Amber Beacons Turret Mounted  
(Qty 2) Mud Flaps Installed  
(Qty 2) Wheel Chocks Provided  
Fire Extinguisher, 5# Provided  
NonSkid Loadspace Floor & Tailshelf  
Install Ford Factory Back Up Camera  
Install Back Up Alarm, 97db  
DOT Reflector Kit Provided  
Paint Tailshelf, Boom Rest & Arch Type Grab Handle White To Match Body  
Includes Labor To Install

Thank You For The Opportunity To Quote.  
Best Regards,

Jason Coats