

RESOLUTION 4A05202024BlackRockCoffee

A RESOLUTION OF THE BURLESON 4A ECONMIC DEVELOPMENT CORPORATION AUTHORIZING THE BOARD PRESIDENT TO EXECUTE THE PERFORMANCE AGREEMENT BETWEEN THE TYPE A CORPORATION AND C&C BURLESON, LLC, AS DEVELOPER, ATTACHED IN EXHIBIT “A” (THE “CONTRACT”); AUTHORIZING THE EXPENDITURE OF FUNDS; REQUEST FOR BURLESON CITY COUNCIL RATIFICATION; AND PROVIDING AN EFFECTIVE DATE.

WHEREAS, the Burleson 4A Economic Development Corporation, known as the “Type A Corporation”, incorporated and certified in October 2000 under the authorization of the Development Corporation Act of 1979; and

WHEREAS, the City of Burleson, Texas (“City”), is a home rule city acting under its charter adopted by the electorate pursuant to Article XI, Section 5 of the Texas Constitution and Chapter 9 of the Local Government Code; and

WHEREAS, the Type A Corporation desires that the Board President, Dan McClendon, execute the Contract on behalf of the Type A Corporation with the Developer; and

WHEREAS, the Type A Corporation desires to perform its obligations and duties as described in the Contract; and

WHEREAS, the Type A Corporation desires the City Council approve this action;

NOW, THEREFORE, BE IT RESOLVED BY THE BURLESON 4A ECONOMIC DEVELOPMENT CORPORATION BOARD OF DIRECTORS, THAT:

Section 1.

The Board President, Dan McClendon, is authorized: (a) to execute on behalf of the Type A Corporation (i) the Contract between the Type A Corporation and the Developer, substantially in the form attached as Exhibit “A”, with an incentive amount not to exceed \$409,596.00, and (ii) any other documents contemplated by the Contract; and (b) to make expenditures in accordance with the terms of the Contract.

Section 2.

The foregoing recitals are adopted and incorporated herein for all purposes.

Section 3.

The Type A Corporation hereby requests that the City Council of the City of Burleson ratify this resolution and actions of the Type A Corporation. Accordingly, this resolution shall take effect immediately after such ratification.

PASSED, APPROVED, AND SO RESOLVED by the Board of Directors of the Burleson
4A Economic Development Corporation on the ____ day of _____, 20____.

Dan McClendon, Board President
Burleson 4A Economic Development Corporation

ATTEST:

Amanda Campos, Secretary

EXHIBIT "A"

PERFORMANCE AGREEMENT BETWEEN THE BURLESON 4A ECONOMIC DEVELOPMENT CORPORATION AND C&C BURLESON, LLC

This Performance Agreement (the "Agreement") is entered into as of _____, 2024 (the "Effective Date") by and between the Burleson 4A Economic Development Corporation, a Texas municipal development corporation ("BEDC"), by and through its Board President, and C&C Burleson, LLC, a Texas limited liability company ("Developer"), by and through its manager.

WITNESSETH:

WHEREAS, the City of Burleson, a Texas home rule municipal corporation ("City"), located in the counties of Johnson and Tarrant, has established a regional economic center with unique architecture in the State Highway 174 corridor ("Wilshire Corridor"); and

WHEREAS, the City desires to encourage and incentivize high quality development comprised of office, retail, restaurants, and commercial along the Wilshire Corridor to, among other things, improve drainage, site access, and walkability; and

WHEREAS, Developer is the current owner of real property in the Wilshire Corridor commonly known as 425 SW Wilshire Blvd in Burleson, Johnson County, Texas, as more particularly described on **Exhibit C** attached hereto (the "Property"); and

WHEREAS, Developer is developing mixed-use facilities on the Property (the "Development") and Developer and the BEDC have previously entered into a development agreement to provide incentives for the Developer to construct the Development and establish development standards; and

WHEREAS, the City of Burleson desires to increase traffic safety and maneuverability on SW Wilshire Blvd; and

WHEREAS, a 2021 conceptual plan prepared for the City by Kimley-Horn identifies existing driveway connections that can be removed, consolidated, or improved to increase the level of service on SW Wilshire Blvd. (the "Plan"), attached hereto as **Exhibit A**; and

WHEREAS, the Plan also recommends improvement to the left turn lane to allow vehicles to safely maneuver off the main road into the drive; and

WHEREAS, Developer has agreed to design and construct improvements to SW Wilshire Blvd adjacent to the Development to include removing one dedicated drive connection to the Development, and the modification of an existing turn lane to serve the remaining shared drive connection to the Development and adjacent commercial

properties; and

WHEREAS, the BEDC Board finds and determines the Development will contribute to an increase in economic development in the City; and

WHEREAS, the BEDC Board finds and determines that the incentives contemplated in this Agreement constitute a “Project” as defined by the Development Corporation Act, codified in Subtitle C-1 of Title 12 of the Texas Local Government Code, in Section 501.103, in that the expenditures are for infrastructure improvements related to streets and roads, drainage, and site improvements necessary to promote new or expanded business development and enterprises; and

NOW, THEREFORE, in consideration of the mutual benefits and promises contained herein and for other good and valuable consideration, the receipt and sufficiency of which is hereby acknowledged, the parties agree as follows:

ARTICLE 1. **AUTHORIZATION**

The Burleson City Council and the BEDC Board both find and determine that this Agreement is authorized by Chapters 501 and 504 of the Texas Local Government Code, and that the incentives contemplated in this Agreement constitute a “Project” as defined by the Development Corporation Act, codified in Subtitle C-1 of Title 12 of the Texas Local Government Code, in Section 501.103.

ARTICLE 2. **DEFINITIONS**

2.01 The terms “Agreement,” “BEDC,” “City,” “Developer,” “Development,” “Effective Date,” “Plan,” “Project,” and “Property,” “Wilshire Corridor” shall have the meanings provided, above.

2.02 “Construction Costs” means Sixty Thousand Seven Hundred Dollars (\$60,700.00) for engineering costs, administrative costs, and legal expenses for the Project and the costs set forth in the bid in **Exhibit B**, plus up to ten percent (10%) additional bid cost for any approved overage, for a total of Four Hundred Nine Thousand Five Hundred Ninety-Six Dollars (\$409,596.00).

2.03 “Event of Bankruptcy” means the dissolution or termination of Developer’s existence as a going business, insolvency, appointment of receiver for any part of Property and such appointment is not terminated within ninety (90) days after such appointment is initially made, any general assignment for the benefit of creditors, or the commencement of any proceeding under any bankruptcy or insolvency laws by or against Developer and such proceeding is not dismissed within ninety (90) days after the filing thereof.

2.04 “Incentives” mean the payment by BEDC to fund the Project, as set forth in this Agreement.

2.05 “Project” means the design and construction of improvements to SW Wilshire Blvd adjacent to the Development, to include the removal of one dedicated drive connection and improvements to a left turn lane in the shared drive connection as depicted on **Exhibit A**.

2.06 “Substantially Complete” with regard to the Project means the date upon which the City or Texas Department of Transportation (TxDOT) issues a Letter of Substantial Acceptance to Developer for completion of the construction of the Project.

ARTICLE 3. **TERM**

The term of this Agreement shall commence on the Effective Date and will terminate when the obligations of each party are complete, including but not limited to, Developer’s Substantial Completion of the Project and BEDC’s finalized payment of the Construction Costs.

ARTICLE 4. **IN GENERAL**

4.01 It is the parties’ intent to cooperate in the implementation of the Plan, attached hereto as **Exhibit A**, in order to increase the level of service and traffic safety along Wilshire Blvd. adjacent to the Development. Developer is responsible for the engineering and construction of the Project and the BEDC has agreed to provide funding for the Project.

4.02 **Exhibits**. The Exhibits to this Agreement, incorporated herein for all purposes, are as follows:

Exhibit A –The Conceptual Removal Plan and Proposed Plan

Exhibit B – The Bid Documents Submitted by Terrell General Contractors, LLC

ARTICLE 5. **COVENANTS OF DEVELOPER**

5.01 Covenants Regarding the Project. In consideration of BEDC agreeing to pay Developer the Incentives in accordance with the terms, provisions, and conditions of this Agreement, Developer agrees to the following:

A. Employ engineers to design the Project.

B. Developer shall commence construction of the Project no later than thirty (30) days after the date of all necessary TxDOT approvals for the Project and Substantially Complete the Project twelve (12) months thereafter.

C. Construction of the Project shall be in full conformance with the Plan, the ordinances of the City of Burleson, applicable state and federal law and shall meet all TxDOT requirements.

ARTICLE 6.
COVENANTS AND INCENTIVES OF BEDC

6.01 Incentives. Subject to Developer complying with its duties and obligations under this Agreement, the BEDC agrees to the Incentives set forth in this Article.

A. BEDC Participation. The BEDC's obligations under this Agreement shall not exceed Four Hundred Nine Thousand Five Hundred Ninety-Six Dollars (\$409,596) for Construction Costs to complete the Project. The BEDC authorizes the City Manager to allocate such funds as permitted by law, and as necessary to meet the BEDC obligations set forth in this Agreement.

6.02 Payment Process. On a monthly basis, as the construction of the Project progresses, Developer shall provide written notice of Construction Costs to the BEDC and provide proof of such costs reasonably satisfactory to the BEDC. Developer agrees that BEDC shall not be required to make any Incentive payment under this Agreement until such time that Developer provides such written notice and proof of Construction Costs. The BEDC may request, and Developer hereby agrees that it will permit reasonable review of information that permits the BEDC to verify that the costs made by Developer for the Project meets or exceeds the requirements of this Agreement. Additionally, the BEDC may request, and Developer hereby agrees that it will permit reasonable inspection of the Project during normal business hours to permit the BEDC to verify that the improvements made by Developer for the Project meet or exceed the requirements of this Agreement. Following written notice of completion and proof of costs reasonably satisfactory to the BEDC for each month Developer provides the proof of such current Construction Costs, BEDC shall pay Developer for those costs up to the allocated Incentive amount specified in Section 6.01, subject to the terms and provisions of this Agreement, within ninety (90) days.

ARTICLE 7.
AUTHORITY; COMPLIANCE WITH LAW

7.01 Developer hereby represents and warrants to the BEDC that it has full lawful right, power, and authority to execute and deliver and perform the terms and obligations of this Agreement and that the execution and delivery of this Agreement has been duly authorized by all necessary action by Developer and this Agreement constitutes the legal, valid and binding obligation of Developer, and is enforceable in accordance with its terms and provisions.

7.02 Notwithstanding any other provision of this Agreement, Developer shall comply with all federal, state, and local laws.

7.03 During the term of this Agreement, Developer agrees not to knowingly employ any undocumented workers at the Development, and if convicted of a violation under 8 U.S.C. Section 1324a(f), Developer shall repay the amount of the Incentives received by Developer as of the date of such violation within one hundred twenty (120) business days after the date Developer is notified by the City or the BEDC of such violation, plus interest at the rate the City of Burleson is paying on the most recent issuance of bonded indebtedness prior to Developer's violation of this Section. This Section shall supersede any other conflicting term in this Agreement and shall survive termination of the Agreement.

7.04 Developer agrees, verifies, and certifies that it does not and during the duration of this Agreement will not:

A. boycott Israel as that term is defined in Texas Government Code Section 808.001 and Chapter 2271, as amended;

B. do business with Iran, Sudan, or a foreign terrorist organization, as defined in Texas Government Code Chapter 2270, as amended;

C. boycott energy companies as defined in Texas Government Code Section 809.001 and Chapter 2274, as amended;

D. operate as a foreign owned or controlled company in connection with a critical infrastructure project as defined in Texas Government Code Chapter 2275, as amended; or

E. discriminate against a firearm trade association as defined in Texas Government Code Chapter 2274, as amended.

7.05 By executing this Agreement, Developer warrants, agrees, verifies, and certifies that to the best of its knowledge and belief, no member of City Council, City Manager, deputy city manager, city secretary, department heads, or deputy department heads of the City has direct or indirect financial interest in the award of this Agreement, or in the services to which this Agreement relates, or in any of the profits, real or potential, thereof, in violation of Section 132 of the Home Rule Charter of the City.

ARTICLE 8. **TERMINATION.**

8.01 Termination. This Agreement shall terminate at the expiration of the Term specified in Article 3 unless terminated earlier as follows:

A. By written agreement of the parties;

B. On the date of termination set forth in a written notice provided by a party

to the other party in the event the other party is in default and breaches any of the terms and conditions, or fails to meet any performance conditions, of this Agreement and such default is not cured within ninety (90) days after the non-breaching party sends notice to the breaching party of such breach;

C. On the date of termination set forth in a written notice by BEDC to Developer if Developer experiences an Event of Bankruptcy;

D. On the date of termination set forth in a written notice by BEDC to Developer if Developer has delinquent ad valorem or sales taxes owed to the City (provided that Developer retains the right to timely and properly protest and/or contest any such taxes), and such delinquent ad valorem or sales taxes owed to the City are not paid within ninety (90) days after the BEDC sends notice to Developer;

E. On the date of termination set forth in a written notice by a party to the other party if either party receives notice that any subsequent federal or state legislation or any decision of a court of competent jurisdiction declares or renders this Agreement invalid, illegal, or unenforceable; or

8.02 No Additional Incentives Following Termination. In the event this Agreement is terminated by the BEDC pursuant to Section 8.01, then Developer shall not be entitled to any additional Incentive payments or other funds paid pursuant to this Agreement from BEDC and the BEDC shall have no further obligation to Developer.

8.03 False Representation or Falsification of Documentation. In the event this Agreement is terminated by the BEDC pursuant to Section 8.01.B. because Developer made any false representation or provided any false documentation of investments, costs, or achievement of any milestone or requirement under this Agreement, then Developer shall within thirty (30) days of the date of termination return to the BEDC any funds received by Developer related to such false representation or report from the date of termination. The terms set forth in this Section shall survive termination.

8.04 Limitation of Liability. Notwithstanding any provision of this Agreement to the contrary, in no event shall BEDC be liable to Developer for consequential, incidental, punitive, special, or exemplary damages, including lost revenues, profits, delays, or other economic loss arising from any cause including breach of warranty, breach of contract, tort, strict liability or any other cause whatsoever. To the extent permitted by law, any statutory remedies that are inconsistent with this provision of the Agreement are waived. The terms set forth in this Section shall survive termination.

8.05 No Waiver. No waiver or any breach of any term or condition of this Agreement shall be construed to waive any subsequent breach of the same or any other term or condition of this Agreement. Any waiver of any term or condition of this Agreement must be in writing and approved by the authorized representatives of the parties and approved by the City Council.

ARTICLE 9.
RIGHT OF OFFSET

Developer agrees that, subject to the provision of notice by BEDC and 90-day period following receipt of notice in which Developer may respond or act, BEDC may offset the amount of any compensation due to Developer for any calendar year under this Agreement against any amount which is: (i) lawfully due to City from Developer, and (ii) not subject to challenge by Developer in a court of competent jurisdiction.

ARTICLE 10.
VENUE AND GOVERNING LAW

This Agreement is performable in Johnson County, Texas and venue of any action arising out of this Agreement shall be exclusively in Johnson County, Texas. This Agreement shall be governed and construed in accordance with the Charter, ordinances, and resolutions of the City of Burleson, applicable federal and state laws, violation of which shall constitute a default of this Agreement. To the extent permitted by law, the laws of the State of Texas shall apply without regard to applicable principles of conflicts of law, and the parties submit to the jurisdiction of the state and federal courts in Burleson, Johnson County, Texas.

ARTICLE 11.
FORCE MAJEURE

Performance of Developer's obligations under this Agreement shall be subject to extension due to delay by reason of events of force majeure, and Developer's obligations shall be abated during any period of force majeure. Force majeure shall include, without limitation, damage or destruction by fire or other casualty, condemnation, strike, lockout, civil disorder, war, issuance of any permit and/or legal authorization (including engineering approvals by any governmental entity), governmental approvals and permits, shortage or delay in shipment of materials or fuel occasioned by any event referenced herein, acts of God, unusually adverse weather or wet soil conditions, pandemic, or other causes beyond the parties' reasonable control, including but not limited to, any court or judgment resulting from any litigation affecting the Project or this Agreement.

ARTICLE 12.
GIFT TO PUBLIC SERVANT OR TO DEVELOPER REPRESENTATIVE

12.01 No Benefit. Each party hereto represents to the other that it has not offered, conferred, or agreed to confer and that it will not offer, confer or agree to confer in the future any benefit upon an employee or official of the other party. For purposes of this Section, "benefit" means anything reasonably regarded as economic advantage, including benefit to any other person in whose welfare the beneficiary is interested, but does not include (i) a contribution or expenditure made and reported in accordance with law or (ii) payment of the Incentives.

12.02 Right of Reimbursement. Notwithstanding any other legal remedies, BEDC may obtain reimbursement for any expenditure made to Developer as a result of the improper offer, agreement to confer, or conferring of a benefit to a City employee or official or a BEDC employee or official.

ARTICLE 13.
ASSIGNMENT

Developer may not assign any part of this Agreement without consent or approval by the BEDC Board of Directors and ratification by the City Council.

ARTICLE 14.
INDEMNIFICATION

14.01 **DEVELOPER EXPRESSLY AGREES TO FULLY AND COMPLETELY DEFEND, INDEMNIFY, AND HOLD HARMLESS THE BEDC, AND ITS OFFICERS, AND EMPLOYEES, AND THE CITY, AND ITS OFFICERS, AND EMPLOYEES, AGAINST ANY AND ALL CLAIMS, LAWSUITS, LIABILITIES, JUDGMENTS, OUT-OF-POCKET COSTS (INCLUDING REASONABLE ATTORNEYS' FEES) AND OUT-OF-POCKET EXPENSES FOR PERSONAL INJURY (INCLUDING DEATH), PROPERTY DAMAGE OR OTHER HARM, DAMAGES OR LIABILITY FOR WHICH RECOVERY OF DAMAGES IS SOUGHT (COLLECTIVELY, "LOSSES"), SUFFERED BY ANY PERSON OR PERSONS, THAT MAY ARISE OUT OF OR BE OCCASIONED BY ANY NEGLIGENT, GROSSLY NEGLIGENT, WRONGFUL, OR STRICTLY LIABLE ACT OR OMISSION OF DEVELOPER OR ITS AGENTS, EMPLOYEES, OR CONTRACTORS, ARISING OUT OF OR IN THE PERFORMANCE OF THIS AGREEMENT; NOTWITHSTANDING THE FOREGOING, IN NO EVENT SHALL DEVELOPER BE RESPONSIBLE FOR, NOR SHALL ITS INDEMNIFICATION OBLIGATIONS SET FORTH IN THIS SECTION 14.01 EXTEND TO, ANY LOSSES ARISING OUT OF OR OCCASIONED BY THE ACTS OR OMISSIONS OF THE BEDC, ITS OFFICERS, AND EMPLOYEES, OR THE CITY, ITS OFFICERS, AND EMPLOYEES, THAT CONSTITUTE GROSS NEGLIGENCE OR WILLFUL MISCONDUCT.** Nothing in this paragraph may be construed as waiving any governmental immunity available to BEDC and the City under state law. This provision is solely for the benefit of Developer, BEDC, and the City and is not intended to create or grant any rights, contractual or otherwise, in or to any other person.

14.02 It is acknowledged and agreed by the parties that the terms hereof are not intended to and shall not be deemed to create a partnership or joint venture among the parties. The City and BEDC (including its past, present and future officers, elected officials, directors, employees and agents of the City) do not assume any responsibility to any third party in connection with Developer's construction of the Development.

ARTICLE 15.
MISCELLANEOUS MATTERS

15.01 Time is of Essence. Time is of the essence in this Agreement. The parties hereto will make every reasonable effort to expedite the subject matters hereof and acknowledge that the successful performance of this Agreement requires their continued cooperation.

15.02 Agreement Subject to Law. This Agreement is made subject to and in accordance with the Bureson Home Rule Charter and ordinances of the City, as amended, and all applicable State and federal laws.

15.03 Interpretation. Each of the parties have been represented by counsel of their choosing in the negotiation and preparation of this Agreement. In the event of any dispute regarding the interpretation of this Agreement, this Agreement will be interpreted fairly and reasonably and neither more strongly for nor against any party based on draftsmanship.

15.04 Counterparts Deemed Original; Electronic Signatures. This Agreement may be executed in any number of counterparts, each of which shall be deemed an original and constitute one and the same instrument. Any pdf-format or other electronic transmission of any signature of a signatory shall be deemed an original and shall bind such signatory.

15.05 Captions. The captions to the various clauses of this Agreement are for informational purposes only and shall not alter the substance of the terms and conditions of this Agreement.

15.06 Complete Agreement. This Agreement embodies the complete agreement of the parties hereto, superseding all oral or written previous and contemporary agreements between the parties and relating to matters in the Agreement, and except as otherwise provided herein cannot be modified without written agreement of the parties to be attached and made a part of this Agreement.

15.07 No Waiver. Nothing contained in this Agreement shall be construed as the granting of any permit or permission required by any City ordinance or regulation, or the waiver of any requirement of any City ordinance or regulation.

15.08 Notice. Any notice to be given or served hereunder or under any document or instrument executed pursuant hereto shall be in writing and shall be (i) delivered personally, with a receipt requested therefore; or (ii) sent by a nationally recognized overnight courier service; or (iii) delivered by United States certified mail, return receipt requested, postage prepaid. All notices shall be addressed to the respective party at its address set forth below, and shall be effective (a) upon receipt or refusal if delivered personally; (b) one business day after depositing, with such an overnight courier service or (c) two (2) business days after deposit in the United States mail, if mailed. Any party hereto may change its address for receipt of notices by service of a notice of such change in accordance with this subsection.

Developer: C&C Burleson, LLC
8350 N. Central Expressway, Suite 1313
Dallas, Texas, 75206
Attn : Chad DuBose

BEDC: Burleson 4A Economic Development Corp.
Attn: Board President
141 West Renfro
Burleson, TX 76028

With a copy to: E. Allen Taylor, Jr., City Attorney
Taylor, Olson, Adkins, Sralla & Elam, L.L.P.
6000 Western Place
Suite 200
Fort Worth, TX 76107

With a copy to: City Manager
City of Burleson, Texas
141 West Renfro
Burleson, TX 76028

15.09 Amendment. This Agreement may only be amended by the mutual written agreement of the parties.

15.10 Severability. In the event any section, subsection, paragraph, subparagraph, sentence, phrase, or word herein is held invalid, illegal, or unenforceable, the balance of this Agreement shall stand, shall be enforceable, and shall be read as if the parties intended at all times to delete said invalid section, subsection, paragraph, subparagraph, sentence, phrase, or word. In the event there shall be substituted for such deleted provision a provision as similar in terms and in effect to such deleted provision as may be valid, legal and enforceable.

15.11 Approval by the City Council Required. The BEDC's action to enter into this Agreement is subject to the approval of the City Council of the City of Burleson, Texas. This Agreement shall not be effective until such Agreement is signed by the parties and the City Council of the City of Burleson, Texas ratifies and approves the BEDC's action to enter into this Agreement.

[Signature pages to follow]

BURLESON 4A ECONOMIC DEVELOPMENT CORPORATION

By: _____

Name: _____

Title: Board President

Date: _____, 2024

STATE OF TEXAS
COUNTY OF _____

This instrument was acknowledged before me on _____, 2024, by _____, known personally by me to be the Board President of the Burleson 4A Economic Development Corporation, on behalf of said entity.

[Notary Seal]

Notary Public, State of Texas

**C&C Burleson, LLC,
A Texas limited liability company**

By: _____
Chad DuBose, Manager

Date: _____, 2024

STATE OF TEXAS
COUNTY OF _____

This instrument was acknowledged before me on _____, 2024 by
Chad DuBose, known personally by me to be the manager of C&C Burleson, LLC, on
behalf of said entity.

[Notary Seal]

Notary Public, State of Texas

EXHIBIT A

Conceptual Removal Plan and Proposed Plan

Plotted By: Lunsford, Piper Date: October 31, 2023 10:55:28am File Path: K:\FTW_Roadway\069311511_SH174_HoodedLefts_CADD\EXHIBIT_Medion Improvements.dwg
 This document, together with the concepts and designs presented herein, is intended only for the specific purpose and client for which it was prepared. Review and improper reliance on this document without written authorization and adaptation by Kimley-Horn and Associates, Inc. shall be without liability to Kimley-Horn and Associates, Inc.

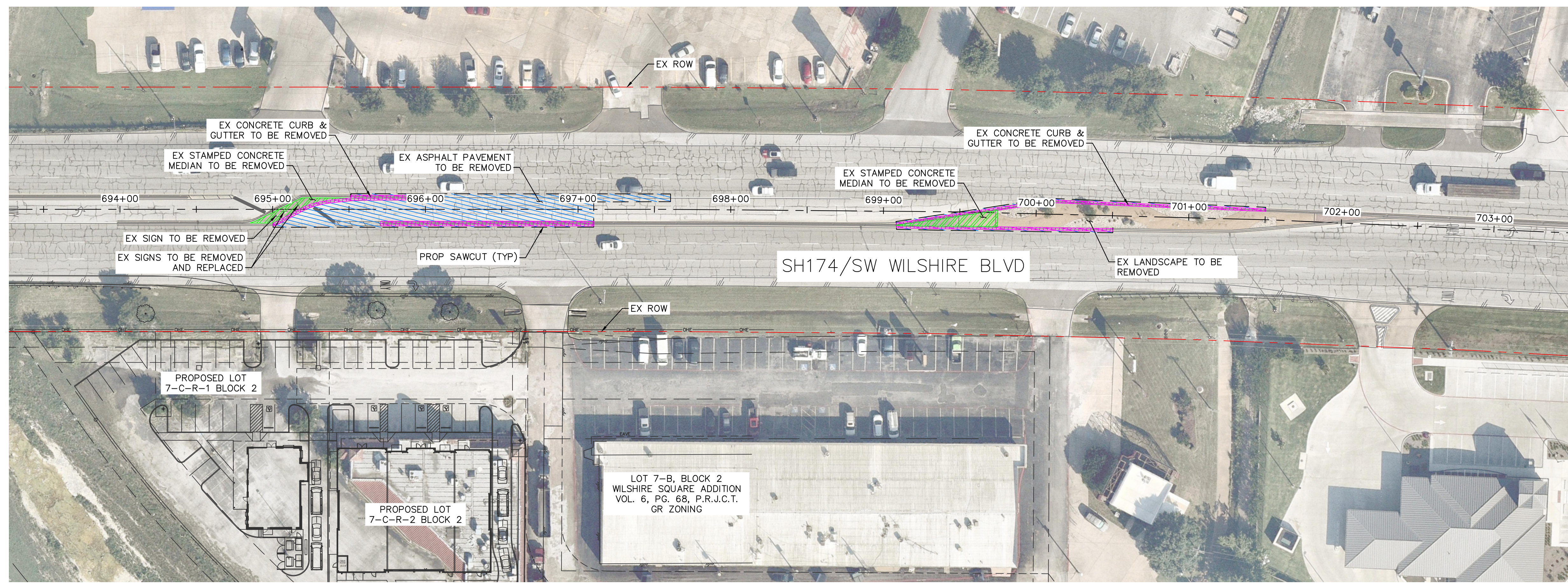

REMOVAL PLAN

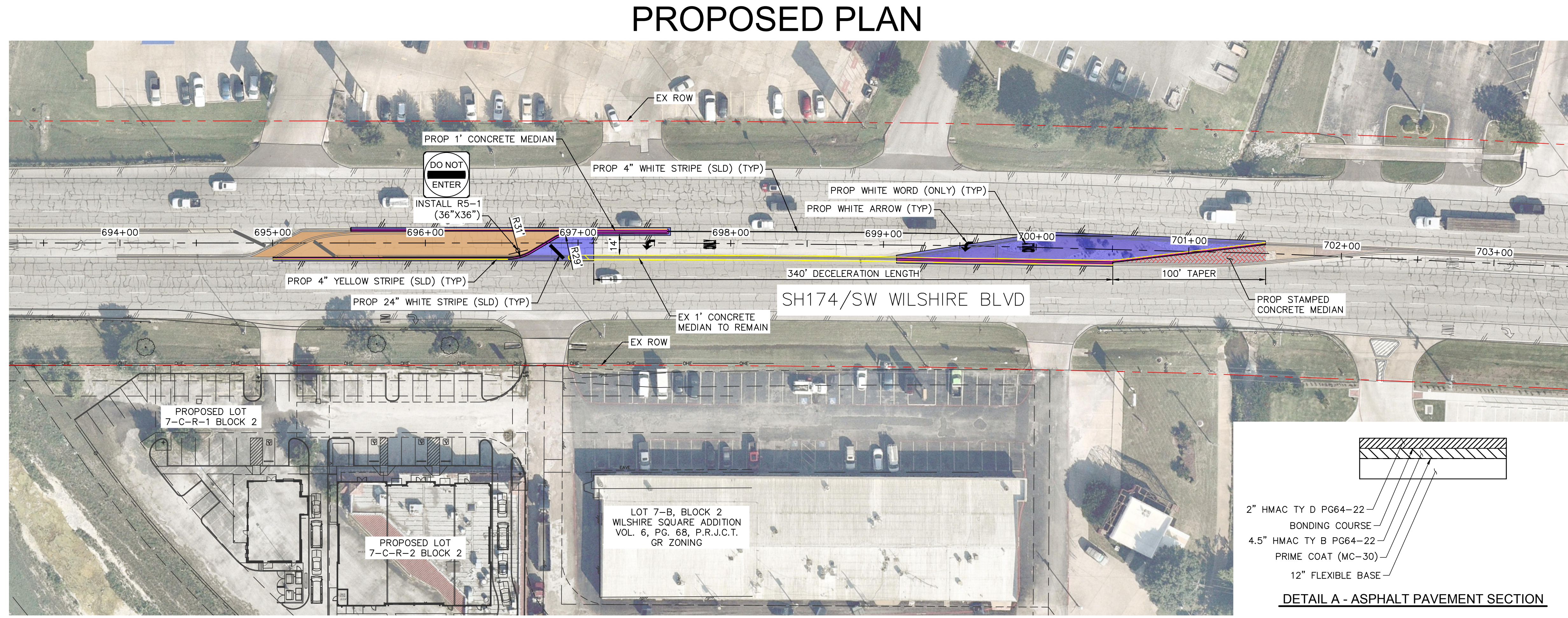

PROPOSED PLAN

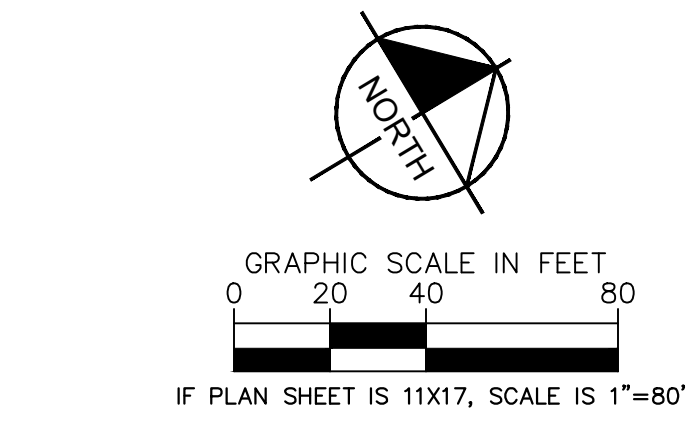
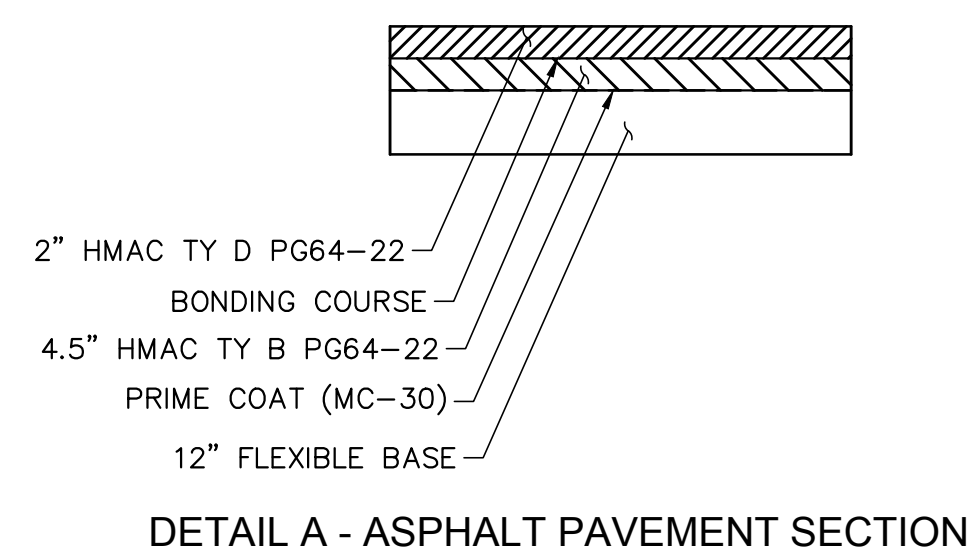

- LEGEND**
- EX ASPHALT TO BE REMOVED
 - EX CONCRETE CURB & GUTTER TO BE REMOVED
 - EX STAMPED CONCRETE MEDIAN TO BE REMOVED

- LEGEND**
- PROPOSED ASPHALT PAVEMENT
 - PROPOSED TY-II CONCRETE CURB & GUTTER
 - PROPOSED HARDSCAPE MEDIAN
 - PROPOSED COLORED STAMPED CONCRETE

- NOTES:**
- DESIGN SPEED: 45 MPH
 - STORAGE LENGTH: 100' MIN
 - DECELERATION LENGTH: 340'
 - TAPER LENGTH: 100'
- *VALUES DETERMINED FROM TXDOT RDM TABLE 3-3



<p>© 2023, KIMLEY-HORN AND ASSOCIATES, INC. 801 CHERRY STREET, UNIT 11 SUITE 1300 FORT WORTH, TX 76102 PHONE: 817-358-6511 WWW.KIMLEY-HORN.COM TEXAS REGISTERED ENGINEERING FIRM F-928</p>	<table border="1" style="width: 100%; border-collapse: collapse;"> <tr> <th style="width: 50%;">NO.</th> <th style="width: 50%;">REVISIONS</th> <th style="width: 50%;">DATE</th> <th style="width: 50%;">BY</th> </tr> <tr> <td> </td> <td> </td> <td> </td> <td> </td> </tr> </table>	NO.	REVISIONS	DATE	BY				
NO.	REVISIONS	DATE	BY						
<p>THIS DOCUMENT IS INCOMPLETE AND IS RELEASED TEMPORARILY FOR INTERIM REVIEW ONLY. IT IS NOT INTENDED FOR CONSTRUCTION, BIDDING, OR PERMIT PURPOSES.</p> <p>KULLEN R. BRITTELL P.E. SERIAL NO. 144144 DATE: OCTOBER 2023</p>	<p>KHA PROJECT: 069311511 DATE: OCTOBER 2023 SCALE: AS SHOWN DESIGNED BY: KRR DRAWN BY: PSL CHECKED BY: DLS</p>								
<p>SH 174 MEDIAN IMPROVEMENTS FOR BLACK ROCK COFFEE CITY OF BURLESON JOHNSON COUNTY, TEXAS</p>									
<p>CONCEPTUAL LAYOUT</p>									
<p>SHEET NUMBER 1</p>									

EXHIBIT B

The Bid Documents Submitted by Terrell General Contractors

BID



Date: April 11th , 2024
 Bid for Burleson Median/Turn

Terrell General Contractors, LLC
 8140 Walnut Hill Suite 250
 Dallas, TX 75231
 (214)865-7611
 Stephen@terrellgc.com

TO: CA Burleson, LLC
 425 Southwest Wilshire Blvd
 Burleson, Texas 76028
 214-701-8455
 Chad@foremark.com

JOB		
SH 174 Median/Turn Lane Improvements - Black Rock Coffee Permit Set		

DESCRIPTION		LINE TOTAL
1 Paving Improvements – Removal of the existing median per Sheet C3, installing new curbs, median and concrete work Per Sheet C4, Signage and Markings per C16, and Traffic Control for 4 weeks to complete this scope of work.		\$235,908.00
2 Landscaping - River Rock, Decomposed Granite, Metal Edging, Trees and shrubs per sheets C5 thru C10. Includes Traffic control for one week that is needed to complete this scope.		\$24,130.00
	Insurance	\$3,172.00
	Supervision	\$22,250.00
	OH&P	\$31,718.00
	Subtotal	\$317,178.00
	Total	\$317,178.00

EXHIBIT C

The Property

Lot 7-C-R, Block 2, of WILSHIRE SQUARE ADDITION, an Addition to the City of Burleson, Johnson County, Texas, according to the Map or Plat thereof recorded in Volume 7, Page 58, of the Plat Records of Johnson County, Texas.