



1004 21

ALL RIGHTS RESERVED



Hover Image to Zoom

SHOP SPRING BLACK FRIDAY DEALS >

Ekena Millwork ♥ ↗
15 in. W x 66 in. H Americraft 2 Equal Louver Exterior Real Wood Shutters (Per Pair), Black

★★★★★ (48) Questions & Answers (25)

\$299⁰⁰ /pair

Pay \$274 after \$25 OFF your total qualifying purchase upon opening a new card.
[Apply for a Home Depot Consumer Card](#)

• [View More Details](#)

Color/Finish: **Black**



Shutter Height (in.): 66

66 ▼

Shutter Width (in.): 15

12 15 18



Hover Image to Zoom

SHOP SPRING BLACK FRIDAY DEALS >

Ekena Millwork ♥ ↗
15 in. W x 64 in. H Americraft 2 Equal Louver Exterior Real Wood Shutters Per Pair in Unfinished

★★★★★ (49) Questions & Answers (25)

\$209⁰⁰ /pair

Pay \$184 after \$25 OFF your total qualifying purchase upon opening a new card.
[Apply for a Home Depot Consumer Card](#)

• [View More Details](#)

Color/Finish: **Unfinished**



Shutter Height (in.): 64

64 ▼

Shutter Width (in.): 15

Specifications

Dimensions

Shutter Height (in.)	64
Shutter Width (in.)	15

Details

Color Family	Brown
Color/Finish	Unfinished
Features	Paintable, Stainable
Material	Wood
Returnable	90-Day
Shape	Rectangular
Shutter Top Shape	Straight Top
Shutter Type	Louvered
Shutter Usage	Functional

Warranty / Certifications

Manufacturer Warranty	N/A
-----------------------	-----

Product Details

About This Product

Hawaiian mango wood shutters are an eco-friendly hand-crafted decorative wood product. Produced from the high-quality mango wood tree, a distinctive textured wood grain offers golden-brown pattern variations. These durable, hardwood exterior shutters age beautifully, while offering a sustainable building product. Available in stunning unfinished stain grade, primed, or one of our long-lasting solid color wood stains, that offer durability against cracking and peeling. Hawaiian mango wood is a highly desired artisan wood and is now available in affordable, durable, and environmentally friendly exterior shutters.

Highlights

- Hawaiian mango wood is both eco-friendly and durable
- Distinctive textures and patterns offer a beautiful pair of exterior shutters
- Strength, density, and attractive looks will instantly upgrade your house
- Available in both stain grade and a variety of beautiful, hand-stained finishes
- Sustainable mango wood offers affordable and environmentally friendly shutter product
- Choose from classic and modern shutter designs
- [Return Policy](#)
- California residents [see Prop 65 WARNINGS](#)

Product Information

Internet # 322801235

Model # RW101LV15X64UNH





La Pietra

THINSTONE VENEERS



Specs

Cuts

Corners

Thickness

Applications

Installation

Available types

- Thinstone 3/4" – 1 1/4"
- 3" – 5" Veneer

DISCLAIMER FOR NATURAL STONE VARIATION:

Natural stone varies in color, veining, and pattern from piece to piece. La Pietra is not responsible for photos used in color literature, websites, or emails, as they may not accurately reflect actual material. Photos are used to reflect the general aesthetic of the material and should not be used for color matching. Always request a free sample from your dealer.



CT NATURAL ROUNDS



WEATHERED ROUNDS - SM & MED



WEATHERED ROUNDS - SM & MED



WEATHERED ROUNDS - MED







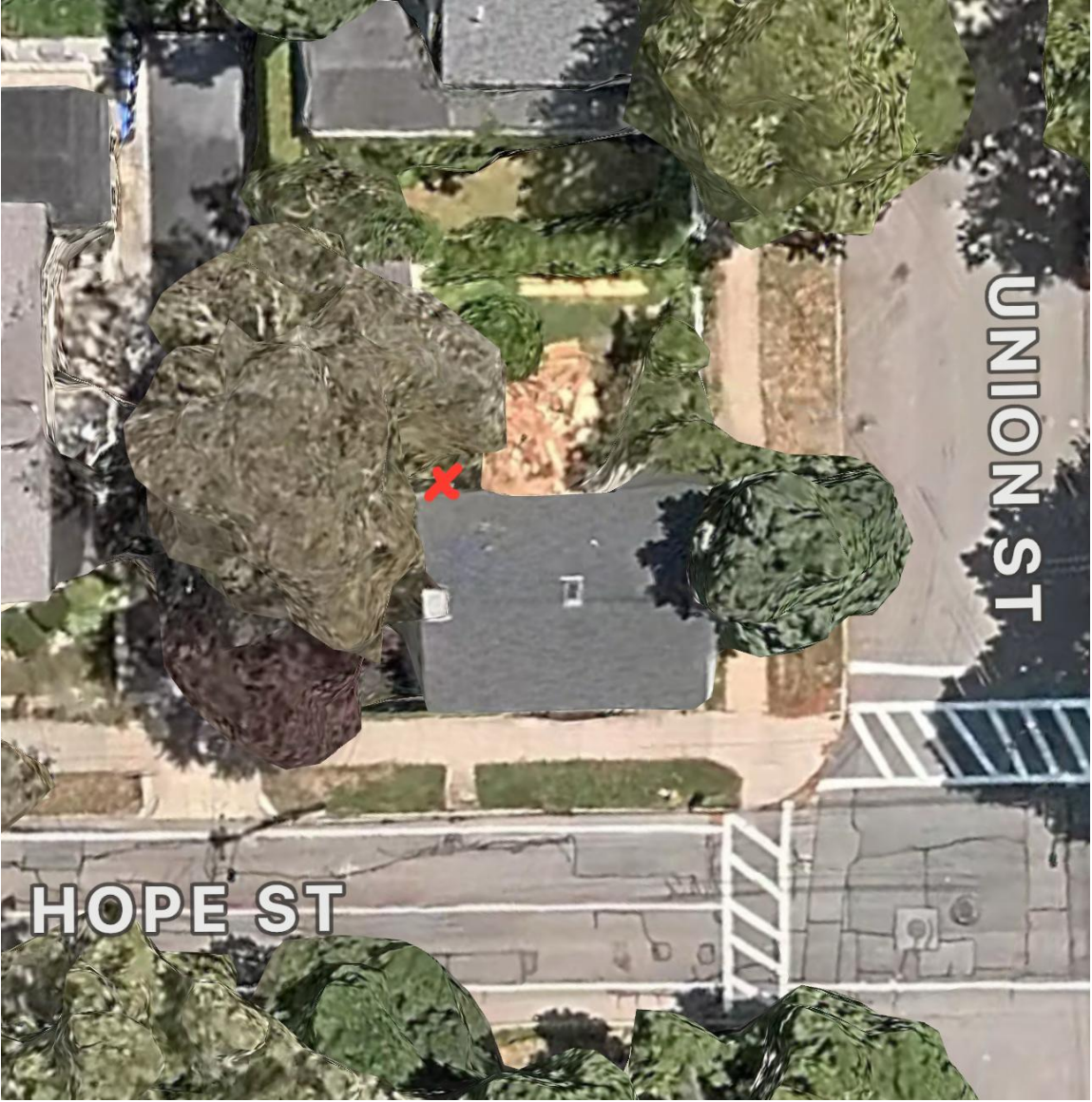

HOPE ST

UNION ST





Basement Doors

Basement doors are ideal for access to basement storage areas and for moving large items into finished basement areas. The wide opening allows storage items such as deck and patio furniture, and large items such as pool tables and furniture, to be easily moved in and out of a basement. Doors meet IRC 2023 building code requirements for emergency egress in finished basement living areas and feature weather resistant construction.



Classic Series Steel Sided

Features:

- Patented gas spring lift assistance for improved operation
- Baked-on Sherwin Williams primer provides durable base for finish paint
- Slide bolt locking mechanism (optional keyed lock kit available)
- Flanged construction and J-channel header shed water and prevent binding due to ice and snow, permitting all-season use
- BILCO also offers a basement door weatherstrip kit and keyed lock kit. (See page 11 for all basement door accessories)

Skip the paint!

Order your door prefinished to match your home. The factory-applied polyester resin finish provides a durable, weather-resistant coating and eliminates the need to paint your door after installation.

(See page 4 for more information)



Basement Door Measuring Guide

Follow the instructions below to calculate the proper size door for your areaway. An electronic version of this sizing guide is also available at BILCO.com. Please contact BILCO if you are unable to find a standard door to fit your areaway.

Areaway — Flat Foundation

Ultra Series and Classic Series Doors

1. Discard your old door and measure (in inches) the dimensions of the areaway foundation.
2. Measure dimension W1, the inside width, and dimension W2, the outside width of the areaway foundation walls. Record your dimensions below and make the calculation shown.
3. Measure dimension L1, the inside length, and dimension L2, the outside length of the areaway foundation walls. Record your dimensions and make the calculation shown.
4. Measure dimension H1, the height from the top of the areaway foundation to the top of the opening in the house foundation.
5. Select the door from the table to the right with a width between W1 and W2 and length between L1 and L2.

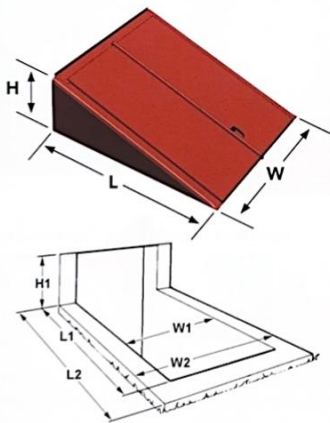

Basement Door Dimensions

Door Size	Width (W) (inches)	Length (L) (inches)	Height (H) (inches)	Door Opening	
				Length (inches)	Width (inches)
B	51	64	22	60	44
C*	55	72	19½	67	48
O	47	58	30	58	40
SL	51	43¼	52	60	44

*Ultra Series Doors are available in Size C only

Record your foundation dimensions here

Width	Length	Height
W1 + 4" = _____	L1 + 2" = _____	H1 = _____
W2 = _____	L2 = _____	

Extensions are available to increase the door length for Size C Ultra and Size C Classic Series doors. Classic Series extensions are available in 6", 12", 18", 24" and 30" lengths and two or more can be mounted back to back to increase the door length. Ultra Series extensions are available in 6" and 12" lengths and two extensions can be combined to increase the door length.

