



*Florida Department of Transportation*

RON DESANTIS  
GOVERNOR

1074 Highway 90  
Chipley, Florida 32428-0607

JARED W. PERDUE, P.E.  
SECRETARY

May 1, 2026

Mr. Larry Cook  
City Mayor  
City of Bonifay  
Transmitted electronically via Email

Project ID No.: 458261-1-57-01  
Road Name: Hubbard St., FAP No.: D326-068-B  
Holmes County, Parcel No.: 1(52000-SIGH)  
Crossing No.: 339933U; RRMP: OOK-758.66

The Department proposes installing of two (2) new flashing light & gate masts with high wind gates and brackets, new batteries and chargers, train detection, R8-8 sign with \$500 minimum fine sign on north side of crossing, add \$500 minimum fine sign to existing R8-8 sign on south side of crossing, standalone ENS signs on break away posts to both sides of crossing, and include updated circuitry plans at Hubbard Street in Bonifay, Holmes County, FL at Crossing No.: 339933U; RRMP: OOK-758.66.

Installation of signal upgrades does not change the signal maintenance at this location.

The project is presently scheduled for completion of negotiations by June 2026. Your cooperation towards having all agreements authorized prior to that date will be appreciated.

Once the attached draft is signed, please return it to our office electronically. After final execution, we will date the agreements and send a copy for your records. No work can take place until the contract is fully executed, and funding is provided.

Should you need additional information please contact me at (850) 330-1557.

Sincerely,

*Travis Hinson*

Travis Hinson  
District Freight and Rail Analyst

Enclosure

STATE OF FLORIDA DEPARTMENT OF TRANSPORTATION  
**RAILROAD REIMBURSEMENT AGREEMENT**  
**GRADE CROSSING TRAFFIC CONTROL DEVICES - MUNICIPAL**

FINANCIAL PROJECT NO.	ROAD NAME OR NUMBER	COUNTY NAME	PARCEL & R/W NUMBER	FAP NUMBER
458261-1-57-01	Hubbard St	Holmes	1(52000-SIGH)	D326-068-B

THIS AGREEMENT, made and entered into this \_\_\_\_\_ day of \_\_\_\_\_, \_\_\_\_\_, by and between the STATE OF FLORIDA DEPARTMENT OF TRANSPORTATION, hereinafter called the DEPARTMENT, and Florida Gulf & Atlantic Railroad, LLC, a corporation organized and existing under the laws of Florida, with its principal place of business in the City of Boca Raton, County of Palm Beach, State of Florida, hereinafter called the COMPANY; and the city of Bonifay, a municipal corporation, hereinafter called the CITY.

WITNESSETH:

WHEREAS, the DEPARTMENT is constructing, reconstructing or otherwise changing a portion of the Public Road System, designated by the Financial Project ID 458261-1-57-01, on Hubbard St, which crosses at grade the right of way and tracks of the COMPANY'S Milepost OOK-758.66, FDOT/AAR Crossing Number 339933U, at or near Bonifay, as shown on DEPARTMENT'S Plan Sheet No. NA, attached hereto as a part hereof; and

NOW, THEREFORE, in consideration of the mutual undertakings as herein set forth, the parties hereto agree as follows:

1. The COMPANY shall furnish the necessary materials and install Automatic Grade Crossing Signals Type III Class III and/or other traffic control devices at said location on an actual cost basis and in accordance with the attached detailed statement of the work, plans and specifications; and the Standard Plans Index 509-070 and 711-001, attached hereto and incorporated by reference and made a part hereof, as well as the FDOT Design Manual (FDM), incorporated by reference and made a part hereof.
2. After installation of said signals is completed, fifty (50%) percent of the expense thereof in maintaining the same shall be borne by the CITY and fifty (50%) percent shall be borne by the COMPANY, as enumerated by the Schedule of Annual Cost of Automatic Highway Grade Crossing Devices attached hereto and by this reference made a part hereof and subject to future revision.
3. After said signals have been installed and found to be in satisfactory working order by the parties hereto, the same shall be immediately put into service, operated and maintained by the COMPANY so long as said COMPANY or its successors or assigns shall operate the said signals at said grade crossing; or until it is agreed between the parties hereto that the signals are no longer necessary or until the said crossing is abandoned; or legal requirements occur which shall cease operation of signals thereat. The COMPANY agrees that any future relocation or adjustment of said signals shall be performed by the COMPANY, but at the expense of the party initiating such relocation. Upon relocation the maintenance responsibilities shall be in accordance with the provisions of this agreement. It is further agreed that the cost of maintaining any additional or replacement signal equipment at the same location will be shared as provided under Paragraph 2. above.

4. Unless otherwise agreed upon herein, the CITY agrees to ensure that at the crossing the advance warning signs and railroad crossing pavement markings will conform to the U.S. Department of Transportation Manual on Uniform Traffic Control Devices within 30 days of notification that the railroad signal improvements have been completed and that such signs and pavement markings will be continually maintained at an acceptable level.

5. The COMPANY hereby agrees to install and/or adjust the necessary parts of its facilities along said road in accordance with the provisions set forth in the:

- (a) DEPARTMENT Procedure No. 725-080-002 Appendix D.4, and Rule 14.57.011 "Public Railroad-Highway Grade Crossing Costs", Florida Administrative Code.
- (b) Federal Highway Administration Federal-Aid Policy Guide, 23 C.F.R. Subchapter G, Part 646, Subpart B, and 23 C.F.R., Subchapter B, Part 140, Subpart I,

and any supplements thereto or revisions thereof, which, by reference hereto, are made a part hereof. The COMPANY further agrees to do all of such work, with its own forces or by a contractor paid under a contract let by the COMPANY, all under the supervision and approval of the DEPARTMENT and the Federal Highway Administration, when applicable.

6. The DEPARTMENT hereby agrees to reimburse the COMPANY for all costs incurred by it in the installation and/or adjustment of said facilities, in accordance with the provisions of Procedure No. 725-080-002 Appendix D-4 "Billing Requirements," and any supplements thereto or revisions thereof. It is understood and agreed by and between the parties hereto that preliminary engineering costs not incorporated within this agreement shall not be subject to payment by the DEPARTMENT.

7. Attached hereto, and by this reference made a part hereof, are plans and specifications of the work to be performed by the COMPANY pursuant to the terms hereof, and an itemized estimate of the cost thereof in the amount of \$113,341.00. All work performed by the COMPANY pursuant hereto, shall be performed according to these plans and specifications as approved by the DEPARTMENT and the Federal Highway Administration if federal aid participating; and all subsequent plan changes shall likewise be approved by the DEPARTMENT and the Federal Highway Administration, when applicable.

8. All labor, services, materials, and equipment furnished by the COMPANY in carrying out the work to be performed hereunder shall be billed by the COMPANY direct to the DEPARTMENT. Separate records as to the costs of contract bid items and force account items performed for the COMPANY shall also be furnished by the COMPANY to the DEPARTMENT.

9. The COMPANY has determined that the method to be used in developing the relocation or installation cost shall be as specified for the method checked and described hereafter:

- (a) Actual and related indirect costs accumulated in accordance with a work order accounting procedure prescribed by the applicable Federal or State regulatory body.
- (b) Actual related indirect costs accumulated in accordance with an established accounting procedure developed by the COMPANY and approved by the DEPARTMENT.
- (c) An agreed lump sum \$ , as supported by a detail analysis of estimated cost attached hereto. (NOTE: This method is not applicable where the estimated cost of the proposed adjustment exceeds \$100,000.)

10. The installation and/or adjustment of the COMPANY'S facility as planned  will  will not involve additional work over and above the minimum reimbursable requirements of the DEPARTMENT. (If upgrading and/or nonreimbursable work is involved at the option of the COMPANY, then credit against the cost of the project is required and will be governed by the method checked and described hereafter):

- (a) \_\_\_\_\_% will be applied to the final billing of work actually accomplished to determine required credit for (betterment) and/or (expired service life) and/or (nonreimbursable segments).
- (b) All work involving nonreimbursable segments will be performed by special COMPANY work or job order number apart and separate from the reimbursable portion of the work; such work or job order number to be \_\_\_\_\_. The COMPANY further agrees to clearly identify such additional work areas in the COMPANY'S plans and estimates for the total work covered by this Agreement.
- (c) \$\_\_\_\_\_ credited for  betterment  expired service life  
 nonreimbursable segments in accord with Article 9.(c) hereinabove.

11. It is specifically agreed by and between the DEPARTMENT and the COMPANY that the DEPARTMENT shall receive fair and adequate credit for any salvage which shall accrue to the COMPANY as a result of the above installation and/or adjustment work.

12. It is further agreed that the cost of all improvements made during this adjustment work shall be borne by the COMPANY, subject only to the DEPARTMENT bearing such portion of this cost as represents the cost of adjustment of previously existing facility, less salvage credit as set forth in the immediately preceding paragraph.

13. Upon completion of the work the COMPANY shall, within one hundred eighty (180) days, furnish the DEPARTMENT with two (2) copies of its final and complete billing of all costs incurred in connection with the work performed hereunder, such statement to follow as closely as possible the order of the items contained in the estimate attached hereto. The totals for labor, overhead, travel expense, transportation, equipment, material and supplies, handling costs and other services shall be shown in such a manner as will permit ready comparison with the approved plans and estimates. Materials shall be itemized where they represent major components of cost in the relocation following the pattern set out in the approved estimate as closely as is possible. Salvage credits from recovered and replaced permanent and recovered temporary materials shall be reported in said bills in relative position with the charge for the replacement or the original charge for temporary use.

The final billing shall show the description and site of the Project; the date on which the first work was performed, or, if preliminary engineering or right-of-way items are involved, the date on which the earliest item of billed expense was incurred; the date on which the last work was performed or the last item of billed expense was incurred; and the location where the records and accounts billed can be audited. Adequate reference shall be made in the billing to the COMPANY'S records, accounts and other relevant documents. All cost records and accounts shall be subject to audit by a representative of the DEPARTMENT. Upon receipt of invoices, prepared in accordance with the provisions of the above indicated Reimbursement Policy, the DEPARTMENT agrees to reimburse the COMPANY in the amount of such actual costs as approved by the DEPARTMENT'S auditor.

14. Payment shall be made only after receipt and approval of goods and services unless advance payments are authorized by the DEPARTMENT's Comptroller under Section 334.044(29), F.S., or by the Department of Financial Services under Section 215.422(14), Florida Statutes (F.S.).

15. In accordance with Section 287.058, Florida Statutes, the following provisions are in this Agreement: If this Contract involves units of deliverables, then such units must be received and accepted in writing by the Contract Manager prior to payments. Bills for fees or other compensation for services or expenses shall be submitted in detail sufficient for a proper preaudit and postaudit thereof.

16. Bills for travel expenses specifically authorized in this agreement shall be submitted and paid in accordance with DEPARTMENT Rule 14-57.011 "Public Railroad-Highway Grade Crossing Costs" and the Federal Highway Administration Federal-Aid Policy Guide, Subchapter B, Part 140, Subpart I "Reimbursement for Railroad Work."

17. In accordance with Section 215.422, Florida Statutes, the following provisions are in this Agreement: Contractors providing goods and services to the Department should be aware of the following time frames. Upon receipt, the Department has five (5) working days to inspect and approve the goods and services, unless the Agreement specifies otherwise. The Department has 20 days to deliver a request for payment (voucher) to the Department of Financial Services. The 20 days are measured from the latter of the date the invoice is received or the goods or services are received, inspected and approved.

If a payment is not available within 40 days, a separate interest penalty at a rate as established pursuant to Section 215.422(3)(b), Florida Statutes, will be due and payable, in addition to the invoice amount, to the Contractor. Interest penalties of less than one (1) dollar will not be enforced unless the Contractor requests payment. Invoices which have to be returned to a Contractor because of Contractor preparation errors will result in a delay in the payment. The invoice payment requirements do not start until a properly completed invoice is provided to the Department.

A Vendor Ombudsman has been established within the Department of Financial Services. The duties of this individual include acting as an advocate for contractors/vendors who may be experiencing problems in obtaining timely payment(s) from a state agency. The Vendor Ombudsman may be contacted at (850) 413-5516 or by calling the Division of Consumer Services at 1-877-693-5236.

18. In the event this contract is for services in excess of TWENTY FIVE THOUSAND DOLLARS (\$25,000.00) and a term for a period of more than one year, the provisions of Section 339.135(6)(a), Florida Statutes, are hereby incorporated:

The Department, during any fiscal year, shall not expend money, incur any liability, or enter into any contract which, by its terms, involves the expenditure of money in excess of the amounts budgeted as available for expenditure during such fiscal year. Any contract, verbal or written, made in violation of this subsection is null and void, and no money may be paid on such contract. The Department shall require a statement from the Comptroller of the Department that such funds are available prior to entering into any such contract or other binding commitment of funds. Nothing herein contained shall prevent the making of contracts for periods exceeding one year, but any contract so made shall be executory only for the value of the services to be rendered or agreed to be paid for in succeeding fiscal years; and this paragraph shall be incorporated verbatim in all contracts of the Department which are for an amount in excess of TWENTY FIVE THOUSAND DOLLARS (\$25,000.00) and which have a term for a period of more than one year.

19. In accordance with Section 287.133 (2)(a), Florida Statutes, the following provisions are included in this Agreement:

A person or affiliate who has been placed on the convicted vendor list following a conviction for a public entity crime may not submit a bid, proposal, or reply on a contract to provide any goods or services to a public entity; may not submit a bid, proposal, or reply on a contract with a public entity for the construction or repair of a public building or public work; may not submit bids, proposals, or replies on leases of real property to a public entity; may not be awarded or perform work as a contractor, supplier, subcontractor, or consultant under a contract with any public entity; and may not transact business with any public entity in excess of the threshold amount provided in s.287.017 for CATEGORY TWO for a period of 36 months following the date of being placed on the convicted vendor list.

20. In accordance with Section 287.134(2)(a), Florida Statutes, the following provisions are included in this Agreement:

An entity or affiliate who has been placed on the discriminatory vendor list may not submit a bid, proposal, or reply on a contract to provide any goods or services to a public entity; may not submit a bid, proposal, or reply on a contract with a public entity for the construction or repair of a public building or public work; may not submit bids, proposals, or replies on leases of real property to a public entity; may not be awarded or perform work as a contractor, supplier, subcontractor, or consultant under a contract with any public entity; and may not transact business with any public entity.

21. In accordance with Section 287.0582, Florida Statutes, the following provision is included in this Agreement:

The Department's obligation to pay under this section is contingent upon an annual appropriation by the Florida Legislature.

22. The COMPANY covenants and agrees that it will indemnify and hold harmless the DEPARTMENT and all of the DEPARTMENT'S officers, agents, and employees from any claim, loss, damage, cost charge, or expense arising out of any act, action, neglect, omission or delay by the COMPANY during the performance of the contract, whether direct or indirect, and whether to any person or property to which the DEPARTMENT or said parties may be subject, except that neither the COMPANY nor any of its sub-contractors will be liable under this section for damages arising out of injury or damage to persons or property directly caused or resulting from the sole negligence of the DEPARTMENT or any of its officers, agents, or employees.

23. COMPANY shall:

1. utilize the U.S. Department of Homeland Security's E-Verify system to verify the employment eligibility of all new employees hired by the COMPANY during the term of the contract; and

2. expressly require any subcontractors performing work or providing services pursuant to the state contract to likewise utilize the U.S. Department of Homeland Security's E-Verify system to verify the employment eligibility of all new employees hired by the subcontractor during the contract term.

3. use steel and iron manufactured in the United States, in accordance with the Buy America provisions of 23 CFR 635.410, as amended. Ensure that all manufacturing processes for this material occur in the United States. As used in this specification, a manufacturing process is any process that modifies the chemical content, physical shape or size, or final finish of a product, beginning with the initial melting and continuing through the final shaping and coating. If a steel or iron product is taken outside the United States for any manufacturing process, it becomes foreign source material. When using steel or iron materials as a component of any manufactured product (e.g., concrete pipe, prestressed beams, corrugated steel pipe, etc.), these same provisions apply. Foreign steel and iron may be used when the total actual cost of such foreign materials does not exceed 0.1% of the total Contract amount or \$2,500, whichever is greater. These requirements are applicable to all steel and iron materials incorporated into the finished work but are not applicable to steel and iron items that the COMPANY uses but does not incorporate into the finished work. Submit a certification from the manufacturer of steel or iron, or any product containing steel or iron, stating that all steel or iron furnished or incorporated into the furnished product was produced and manufactured in the United States or a statement that the product was produced within the United States except for minimal quantities of foreign steel and iron valued at \$ (actual cost). Submit each such certification to the Engineer prior to incorporating the material or product into the project. Prior to the use of foreign steel or iron materials on a project, submit invoices to document the actual cost of such material, and obtain the Engineer's written approval prior to incorporating the material into the project; and

4. comply with all the requirements imposed by Title VI of the Civil Rights Act of 1964, the regulations of the U.S. Department of Transportation issued thereunder, and the assurance by the COMPANY pursuant thereto. The COMPANY shall include the attached Title VI / Nondiscrimination Assurance in all contracts with consultants and contractors performing work on the Project that ensure compliance with Title VI of the Civil Rights Act of 1964, 49 C.F.R. Part 21, and related statutes and regulations.

24. It is understood and agreed by the parties to this Agreement that if any part, term, or provision of this Agreement is held illegal by the courts or in conflict with any law of the State of Florida, the validity of the remaining portions or provisions shall not be affected, and the rights and obligations of the parties shall be construed and enforced as if the Agreement did not contain the particular part, term, or provision held to be invalid.

25. Any questions or matters arising under this Agreement as to validity, construction, enforcement, performance, or otherwise, shall be determined in accordance with the laws of the State of Florida. Venue for any action arising out of or in any way related to this Agreement shall lie exclusively in a state court of appropriate jurisdiction in Leon County, Florida.

26. The parties agree to bear their own attorney's fees and costs with respect to this Agreement.

27. The parties agree that this Agreement is binding on the parties, their heirs-at-law, and their assigns and successors in interest as evidenced by their signatures and lawful executions below.

28. A modification or waiver of any of the provisions of this Agreement shall be effective only if made in writing and executed with the same formality as this Agreement.

IN WITNESS WHEREOF, the parties hereto have caused these presents to be executed by their duly authorized officers, the day and year first above written.

STATE OF FLORIDA  
DEPARTMENT OF TRANSPORTATION

BY: \_\_\_\_\_  
(TITLE: Timothy Smith - District Three Secretary )

---

---

COMPANY: Florida Gulf & Atlantic Railroad, LLC

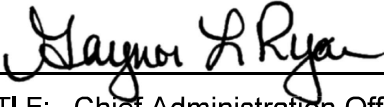
BY:   
(TITLE: Chief Administration Officer/ Chief Human Resource Officer)

---

---

CITY OF Bonifay , FLORIDA

BY: \_\_\_\_\_  
(TITLE: \_\_\_\_\_ )

---

---

Legal Review  
BY: \_\_\_\_\_  
Attorney - DOT                      Date

Approved as to Funds Available  
BY: \_\_\_\_\_  
Comptroller - DOT                      Date

Approved as to FAPG Requirements  
BY: Exempt from FHWA Review  
FHWA                                      Date

**CITY RESOLUTION**  
**GRADE CROSSING AND CROSSING TRAFFIC CONTROL DEVICES, FUTURE RESPONSIBILITY**

FINANCIAL PROJECT NO.	ROAD NAME OR NUMBER	COUNTY NAME	PARCEL & R/W NUMBER	FAP NUMBER
458261-1-57-01	Hubbard St.	HOLMES	1 (52000-SIGH)	D326-068-B

A RESOLUTION AUTHORIZING EXECUTION OF A RAILROAD REIMBURSEMENT AGREEMENT FOR THE CONSTRUCTION OF RAILROAD GRADE CROSSINGS, INSTALLATION OF TRAFFIC CONTROL DEVICES FOR RAILROAD GRADE CROSSINGS, AND FUTURE MAINTENANCE AND ADJUSTMENT OF SAID CROSSINGS AND DEVICES; PROVIDING FOR THE FUTURE EXPENDITURE OF FUNDS; AND PROVIDING WHEN THIS RESOLUTION SHALL TAKE EFFECT.

RESOLUTION NO. \_\_\_\_\_

WHEREAS, the State of Florida Department of Transportation is constructing, reconstructing, or otherwise changing a portion of the public road system, on Hubbard St, which shall call for the installation and maintenance of railroad grade crossings and traffic control devices for railroad grade crossings over or near said highway; and

NOW, THEREFORE, BE IT RESOLVED BY THE CITY COMMISSION OF THE CITY OF Bonifay, FLORIDA:

That the City of Bonifay enter into a RAILROAD REIMBURSEMENT AGREEMENT with the State of Florida Department of Transportation and the Florida Gulf & Atlantic Railroad, LLC. Company for the installation and maintenance of certain grade crossings and traffic control devices for grade crossings designated as Financial Project ID 458261-1-57-01 on Hubbard St which crosses the right of way and tracks of the Company at FDOT/AAR Crossing No. 339933U located in Bonifay, Florida; and

That the City assumes its share of the costs for future maintenance and/or adjustment of said grade crossings and traffic control devices for grade crossings as designated in the RAILROAD REIMBURSEMENT AGREEMENT; and

That the Mayor and City Clerk be authorized to execute such agreements with the State of Florida Department of Transportation and the Florida Gulf & Atlantic Railroad, LLC. Company as herein described; and

That this RESOLUTION shall take effect immediately upon adoption.

Duly Adopted by the City Commission of the City of Bonifay, Florida, this \_\_\_\_\_ day of \_\_\_\_\_, \_\_\_\_.

\_\_\_\_\_  
Authorized Signature

Name: \_\_\_\_\_

Title: \_\_\_\_\_

ATTEST: \_\_\_\_\_ (SEAL)

Authorized Signature

Name: \_\_\_\_\_

Title: \_\_\_\_\_

**WORK DESCRIPTION GRADE CROSSING TRAFFIC CONTROL DEVICES**

FINANCIAL PROJECT NO.	ROAD NAME OR NUMBER	COUNTY NAME	PARCEL & R/W NUMBER	FAP NUMBER
458261-1-57-01	Hubbard St	HOLMES	1(52000-SIGH)	D326-0268-B

## RAILROAD COMPANY

Florida Gulf & Atlantic Railroad, LLC

- A. JOB DESCRIPTION & LOCATION: Install two (2) new flashing light & gate masts with high wind gates and brackets, new batteries, train detection, R8-8 signs with \$500 minimum fine signs, standalone ENS signs on break away posts to both sides of crossing, and include updated circuitry plans
- B. TYPE OF ROADWAY FACILITY: 2 way
- C. FDOT/AAR XING NO.: 339933U RR MILE POST TIE: OOK-758.66
- D. TYPE CROSSING PROPOSED: Asphalt & Timber Class: III DOT INDEX: 17882
- E. STATUS AND PROPOSAL:
1. EXISTING DEVICES (See Agreement dated \_\_\_\_\_)
    - a.  None-New Crossing.
    - b.  Crossbuck and Disk
    - c.  Flashing Signals with Disk
    - d.  Flashing Signals with Cantilever
    - e.  Flashing Signals with Gates
    - f.  Flashing Signals with Cantilever and Gates
  2. PROPOSED DEVICES (Safety Index Rating \_\_\_\_\_)
    - a.  No revision required
    - b.  Crossbuck and Disk
    - c.  Flashing Signals and Disk
    - d.  Flashing Signals with Cantilever
    - e.  Flashing Signals with Gates.
    - f.  Flashing Signals with Cantilever and Gates.
    - g.  Relocate existing signal devices
      - (1)  (With-Without) addition of Gates
      - (2)  ((With-Without) synchronization with highway traffic signals
      - (3)  ((With-Without) constant warning time
- F. COMMUNICATION AND/OR POWER LINE ADJUSTMENTS
1.  By Others (\_\_\_\_\_ Company.)
  2.  By Railroad Company.
- G. AUTHORITY REQUESTED (Draft attached:  Yes  No)
1.  Agreement (Third Party Participating FGA/ City of Bonifay/FDOT )
  2.  Supplemental Agreement No. \_\_\_\_\_
  3.  Crossing Permit
  4.  Estimate for Change Order No. \_\_\_\_\_
  5.  Letter of Authority
  6.  Letter of confirmation (No Cost to Department)
- H. OTHER REMARKS: Negotiations to be completed by: FDOT/FGA/ City of Bonifay  
Negotiations to be completed by: June 2026  
Signal installation target date: September 2026  
Synchronization: (Draft attached :  Yes  No)

## **EXHIBIT B**

The Company shall:

1. adhere to all Buy America requirements (23 CFR 635.410) to ensure that all manufacturing processes of steel and iron occur in the United States; and
2. ensure that prefabricated items that contain steel must also comply with Buy America; and
3. provide Buy America certifications that include correct language, project information, and the material's delivery date.

## EXHIBIT C

The Company understands:

1. that while FHWA1273 does not apply to force account work performed by rail companies, FHWA-assistance is subject to Title VI (42 U.S.C. § 2000d et seq); and
2. requires appropriate assurances by providing an executed Title VI / Nondiscrimination Assurance, including Appendices A and E.

STATE OF FLORIDA DEPARTMENT OF TRANSPORTATION  
**RAILROAD GRADE CROSSING TRAFFIC CONTROL DEVICES**  
**ANNUAL MAINTENANCE COSTS**

725-090-41  
RAIL  
06/21

FINANCIAL PROJECT NO.	ROAD NAME OR NUMBER	COUNTY NAME	PARCEL & R/W NUMBER	FAP NUMBER
458261-1-57-01	Hubbard St	Holmes	1(52000-SIGH)	D326-068-B

COMPANY NAME: Florida Gulf & Atlantic Railroad, LLC

A. FDOT/AAR XING NO.: 339933U RR MILE POST TIE: OOK-758.66

B. TYPE SIGNALS PROPOSED: III CLASS: III DOT INDEX: 17882

**SCHEDULE OF ANNUAL COST OF AUTOMATIC  
HIGHWAY GRADE CROSSING TRAFFIC CONTROL DEVICES**

Annual Maintenance Cost Exclusive of Installation

<u>CLASS</u>	<u>DESCRIPTION</u>	<u>COST*</u>
I	2-Quadrant Flashing Lights with One Track	\$2,608.00
II	2-Quadrant Flashing Lights with Multiple Tracks	\$3,451.00
<b>III</b>	<b>2-Quadrant Flashing Lights and Gates with One Track</b>	<b>\$3,934.00</b>
IV	2-Quadrant Flashing Lights and Gates with Multiple Tracks	\$4,940.00
V	3 or 4-Quadrant Flashing Lights and Gates with One Track	\$7,777.00
VI	3 or 4-Quadrant Flashing Lights and Gates with Multiple Tracks	\$9,759.00

AUTHORITY: FLORIDA ADMINISTRATIVE RULE 14-57.011  
Public Railroad-Highway Grade Crossing Costs

EFFECTIVE DATE: July 22, 1982

GENERAL AUTHORITY: 334.044, F.S.

SPECIFIC LAW IMPLEMENTED: 335.141, F.S.

\*This schedule will become effective July 1, 2021 and will be reviewed every 5 years and revised as appropriate based on the Consumer Price Index for all Urban Consumers published by the U.S. Department of Labor.

Crossing No: 339933U		Roadway: HUBBARD ST		RR Street:		District: 3		County: Holmes			
PUBLIC HWY		AT GRADE Residential		City: BONIFAY		IN CITY		OPEN--TRACK ACTIVE			
Rank 2025: 1800		SR No.:		RR Company:		FGA		Date: 11/05/2025			
Rank 2024: 1785		CR No.:		Division Name:		JACKSONVILLE		Team Members: FDOT: Kelli			
Rank 2023: 1764		US No.:		Subdivision Name:		P&A		Phillips, Bryan Shelmadine,			
		Latitude: 30.788900		Branch Name:		N/A		Brian Owens			
		Longitude: -85.670000		RR Milepost:		758.66		FGA: Brian Lolley			
Field Review Comments: Signal equipment is antiquated.											
City to trim vegetation on north side of crossing (blocking flashing light mast)											
Team Recommendations: Railroad to install 2 new flashing light & gate masts with high wind gates and brackets,											
new batteries and chargers. train detection. R8-8 sign with \$500 minimum fine sign on north side of crossing. add											
\$500 minimum fine sign to existing R8-8 sign on south side of crossing. standalone FNS signs on break away posts											
Highway Speed:		25		<input type="checkbox"/>		Train Speed Range:		25-40			
Crossing Angle:		60-90 DEG		<input type="checkbox"/>		Max Time Table Speed:		40			
AADT:		253 (2011)		<input type="checkbox"/>		Day Thru/Switch:		2/1			
Percent Trucks:		0 (2007)		<input type="checkbox"/>		Night Thru/Switch:		1/0			
School Buses:		26 (2026)		<input type="checkbox"/>		Train Service: Freight					
Street Types:		Two-Way Street		<input type="checkbox"/>		Passenger Count/Day:		0			
Thru Lanes:		2		<input type="checkbox"/>		Train Count Date:		01/01/2017			
Aux Lanes:		0		<input type="checkbox"/>		Main Tracks:		1			
Hazmat Route?		NO		<input type="checkbox"/>		Other Tracks:					
Emergency Services Route?		YES		<input type="checkbox"/>		Train Signals?		NO			
Emergency Notification Signs:		YES		<input type="checkbox"/>		Train Signal Proximity:		NO			
Crossbuck(4x4 post):		0		<input type="checkbox"/>		Train Detection:		Motion Detection			
Crossbuck Sign:		2		<input type="checkbox"/>		Event Recorder?		N			
Stop Sign:		0		<input type="checkbox"/>		Number of Bells:		1			
Yield Sign:		0		<input type="checkbox"/>		Post Mounted Flashing Lights:		2			
Low Ground Clearance Signs:		0		<input type="checkbox"/>		Backlights, Incandescent					
Exempt Signs:				<input type="checkbox"/>		Roadway Gate Count:		2			
Trespass Signs:		NO		<input type="checkbox"/>		Pedestrian Gate Count:		0			
W10-1		2		R10-6a		0		W8-1		0	
W10-2		0		R11-2		0		W10-8		0	
W10-3		0		R15-2P		0		W10-9		0	
W10-4		0		R15-6		0		W10-9P		0	
W10-11		0		R15-6a		0		W10-11a		0	
W10-12		0		R15-7		0		W10-11b		0	
R3-1a		0		R15-7a		0		W10-13P		0	
R3-2a		0		R15-8		0		W10-14P		0	
R8-8		2		Pvt Crossing		0		W10-14aP		0	
R8-9		0		Look Out		0		W10-15P		0	
R8-10		0		R8-8 w/Beacon		0		Slow		0	
R8-10a		0		W3-1				W10-1w/Beacon		0	
R10-6		0		W3-3				LED Signs		0	
Surface Installment Date:				<input type="checkbox"/>				12" Count:		4	
Surface Type:				<input type="checkbox"/>				LED Count:		0	
Pvmt Mrk:				<input type="checkbox"/>				Install - Upgrade:		-- 01/01/1979	
Surface Condition:		EXCELLENT		<input type="checkbox"/>				Maintenance Responsibility:		CITY	
Approach:		B = Uneven		<input type="checkbox"/>				Roadway Paved:		YES	
Vehicle Reaction:		B = Vibrating		<input type="checkbox"/>				Tracks run down street?		NO	
Driver Reaction:		C = Most drivers slow down		<input type="checkbox"/>				Sidewalks on Crossing Approach?		NO	
Rail/Pad Movement:		B = Uneven		<input type="checkbox"/>				Sidewalks Thru Crossing?		N/A	
Incident History:				<input type="checkbox"/>				Crossing illuminated?		YES	
				<input type="checkbox"/>				Commerical Power?		YES	
				<input type="checkbox"/>				Alternative Power?		YES	
Recommended Warning Device: FL & G											



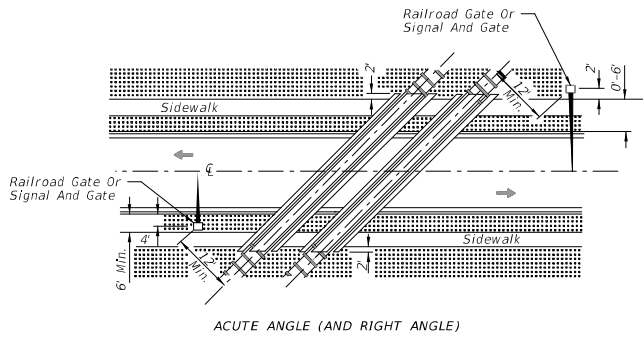

ACUTE ANGLE (AND RIGHT ANGLE)

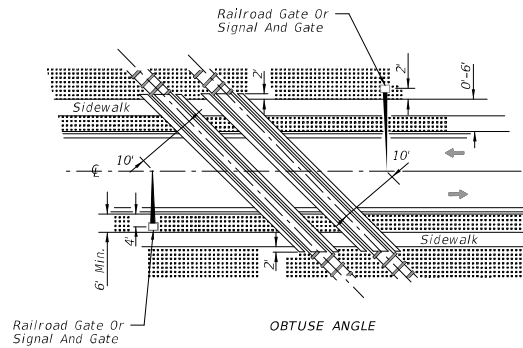

OBTUSE ANGLE

SIGNAL PLACEMENT AT RAILROAD CROSSING  
(2 LANES, CURB & GUTTER)

SIGNAL PLACEMENT AT RAILROAD CROSSING  
(2 LANES, CURB & GUTTER)

**NOTES:**

1. The location of flashing warning devices and stop lines shall be established based on future (or present) installation of gate with appropriate track clearances.
2. Where plans call for railroad traffic control devices to be installed in curbed medians, the minimum median width shall be 12'-6".
3. Location of railroad traffic control device is based on the distance available between face of curb & sidewalk. 0' to 6' - Locate device outside sidewalk. Over 6' - Locate device between face of curb and sidewalk.
4. Stop line to be perpendicular to edge of roadway, approx. 15' from nearest rail; or 8' from and parallel to gate when present.
5. When a cantilevered-arm flashing warning device is used, the minimum vertical clearance shall be 17'-6" from above the Crown of Roadway to the Lowest Point of the Overhead Signal Unit.

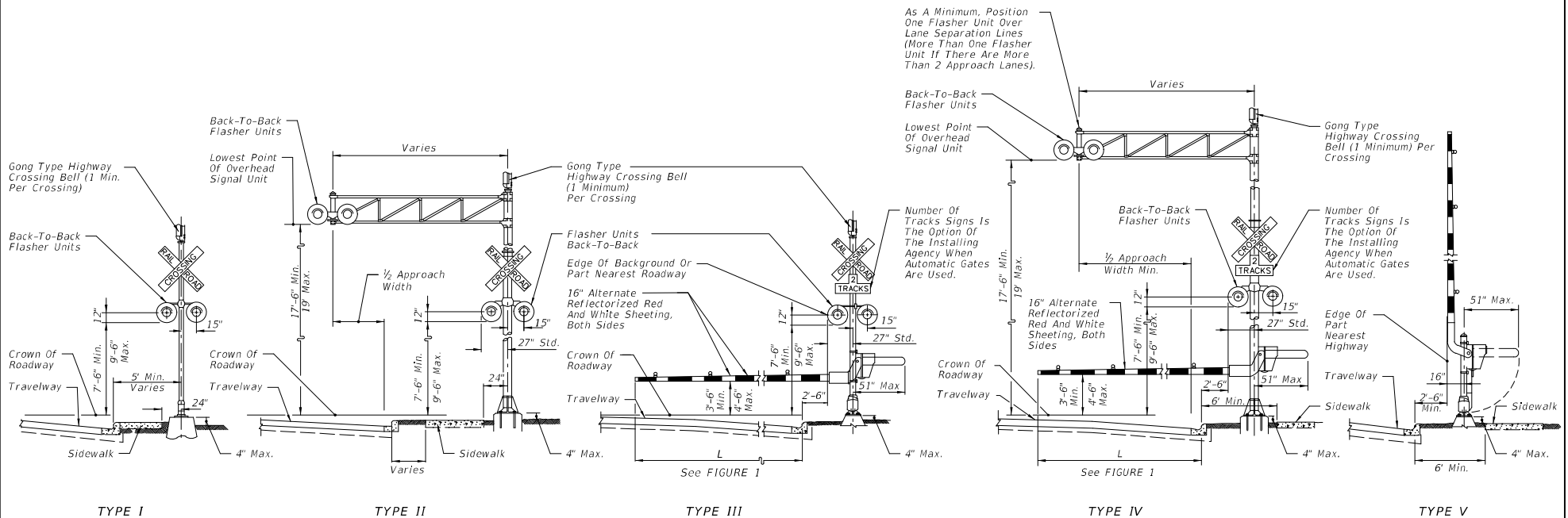

TRAFFIC CONTROL DEVICES FOR CURBED ROADWAY

9/10/2024 1:11:19 PM

LAST REVISION 11/01/23	DESCRIPTION:	 FY 2025-26 STANDARD PLANS	<b>RAILROAD GRADE CROSSING TRAFFIC CONTROL DEVICES</b>	INDEX 509-070	SHEET 2 of 3
---------------------------	--------------	---	--	------------------	-----------------

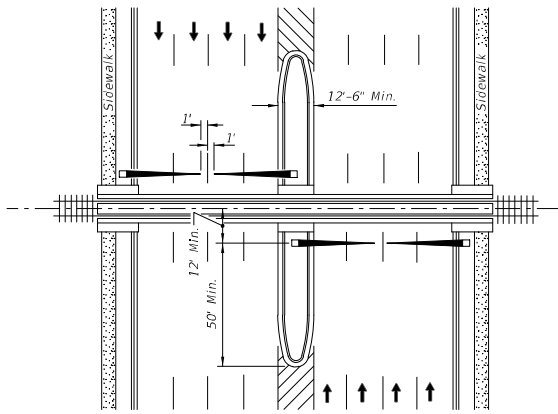

PLAN

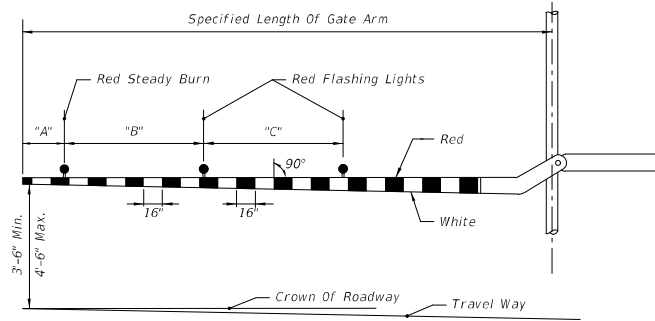

GATE ARM DETAIL

RAILROAD GATE ARM LIGHT SPACING			
Specified Length Of Gate Arm	Dimension "A"	Dimension "B"	Dimension "C"
14 Ft.	6"	36"	5'
15 Ft.	18"	36"	5'
16-17 Ft.	24"	36"	5'
18-19 Ft.	28"	41"	5'
20-23 Ft.	28"	4'	5'
24-28 Ft.	28"	5'	5'
29-31 Ft.	36"	6'	6'
32-34 Ft.	36"	7'	7'
35-37 Ft.	36"	9'	9'
38 And Over	36"	10'	10'

**NOTE:**

For additional information see the "Manual On Uniform Traffic Control Devices", Part B; The "Traffic Control Handbook", Part VIII; and AASHTO "A Policy On Geometric Design Of Streets And Highways".

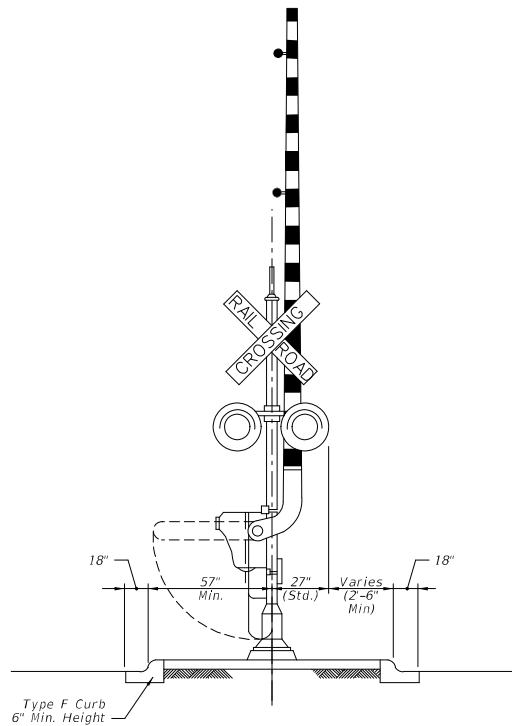

MEDIAN SECTION AT SIGNAL GATES

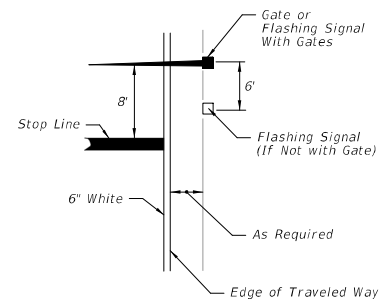

RELATIVE LOCATION OF CROSSING TRAFFIC CONTROL DEVICES

MEDIAN SIGNAL GATES FOR MULTILANE UNDIVIDED URBAN SECTIONS  
(Three or More Driving Lanes in one Direction, 45 mph or less)

9/10/2024 1:11:26 PM

LAST REVISION 11/01/23	REVISION	DESCRIPTION:	 FY 2025-26 STANDARD PLANS	RAILROAD GRADE CROSSING TRAFFIC CONTROL DEVICES	INDEX 509-070	SHEET 3 of 3
---------------------------	----------	--------------	----------------------------------	--	------------------	-----------------