

# MEMORANDUM

TO: Planning and Zoning Board

DATE: November 28, 2023

RE: Variance Application – 3104 Indian Drive

Public Hearing #2023-09-028 - PURSUANT TO BELLE ISLE CODE SEC. 42-64 AND 50-102 (A) (1), THE CITY OF BELLE ISLE PLANNING & ZONING BOARD WILL CONSIDER AND TAKE ACTION ON A REQUESTED VARIANCE TO ALLOW A DETACHED METAL GARAGE TO BE BUILT ARCHITECTURALLY DIFFERENT FROM THE PRINCIPAL BUILDING WITH UNLIKE MATERIALS, SUBMITTED BY APPLICANT MARK ADAMS, LOCATED AT 3104 INDIAN DRIVE, BELLE ISLE, FL 32812 ALSO KNOWN AS ORANGE COUNTY TAX PARCEL ID #29-23-30-4389-03-040.

## Background:

1. On October 4, 2023, the applicant submitted a variance application and the required paperwork.
2. A Notice of Public Hearing legal advertisement was placed in the Orlando Sentinel on Sat., Nov 18, 2023.
3. Letters to the abutting property owners were mailed within 300 feet of the subject property on Nov 14, 2023.

The Board may adopt all, some, or none of these determinations as part of their findings-of-fact. The Board may also add any additional findings of fact that are presented at the public hearing. The Board must determine if the criteria outlined in Chapter 42, Article III, Section 42-64(1) of the Land Development Code have been met and approve, approve with conditions, or deny this request.

## SAMPLE MOTION TO APPROVE:

"I MOVE, PURSUANT TO BELLE ISLE CODE SEC. 42-64 AND 50-102 (A) (1), **TO APPROVE** A DETACHED METAL GARAGE TO BE BUILT ARCHITECTURALLY DIFFERENT FROM THE PRINCIPAL BUILDING WITH UNLIKE MATERIALS SUBMITTED BY APPLICANT MARK ADAMS, LOCATED AT 3104 INDIAN DRIVE, BELLE ISLE, FL 32812 ALSO KNOWN AS ORANGE COUNTY TAX PARCEL ID #29-23-30-4389-03-040.

## SAMPLE MOTION TO DENY:

"I MOVE, PURSUANT TO BELLE ISLE CODE CODE SEC. 42-64 AND 50-102 (A) (1), HAVING NOT BEEN MET, **TO DENY** *[use only if NONE of the justifying criteria have been met] the requirements of, Subsections: [state only the subsections below that are not satisfied] having NOT been met; [may be used in addition to above or alone]* A DETACHED METAL GARAGE TO BE BUILT ARCHITECTURALLY DIFFERENT FROM THE PRINCIPAL BUILDING WITH UNLIKE MATERIALS SUBMITTED BY APPLICANT MARK ADAMS, LOCATED AT 3104 INDIAN DRIVE, BELLE ISLE, FL 32812 ALSO KNOWN AS ORANGE COUNTY TAX PARCEL ID #29-23-30-4389-03-040.

Or the Board can request that it be tabled to a date certain to allow for revisions as discussed.

**SUBSECTION (D)**, a literal enforcement of the provisions of the zoning ordinances would result in unnecessary hardship and that said hardship is created by special conditions and circumstances peculiar to the land, structure or building involved, including but not limited to dimensions, topography or soil conditions.

**SUBSECTION (E)**, personal hardship is not being considered as grounds for a variance since the variance will continue to affect the character of the neighborhood after title to the property has passed and that the special conditions and circumstances were not created in order to circumvent the Code or for the purpose of obtaining a variance.

**SUBSECTION (F)**, the variance is the minimum variance that will make possible the reasonable use of the land, building or structure.

**SUBSECTION (G)**, the granting of the variance will be in harmony with the general purpose and intent of the Code, will not be injurious to the neighborhood, will not be detrimental to the public welfare, and will not be contrary to the public interest.



# City of Belle Isle

1600 Nela Avenue, Belle Isle, FL 32809  
 Tel 407-851-7730 \* Fax 407-240-2222 \* www.belleislefl.gov

## Variance and Special Exception Application

City Code Chapter 42, Art. II, Sec. 41-61 thru 41-72 AND Sec 42-64 Land Development Code

APPLICANT <i>Mark Adams</i>	OWNER Mark Adams
ADDRESS	PROJECT ADDRESS 3104 Indian Drive Belle Island FL 32812
CONTACT NUMBER	OWNER'S CONTACT NUMBER 407-435-4930
EMAIL	OWNER'S EMAIL mfa4533@aol.com
PARCEL ID# 29-23-30-4389-03-040	
LAND USE CLASSIFICATION R-1-AA	ZONING DISTRICT R-1-AA
SECTION OF THE CODE VARIANCE REQUESTED ON 50-102 (a) (1) sentence 5	
DETAILED VARIANCE REQUEST for the detached garage to be build of unalike materials than the principal building is.	
<ul style="list-style-type: none"> <li>The applicant hereby states that the property for which this hearing is requested has not been the subject of a hearing before the Planning and Zoning Board of the kind and type requested in the application within nine (9) months. Further, the requested user does not violate any deed restriction of the property.</li> <li>By applying, I authorize City of Belle Isle employees and members of the P&amp;Z Board to enter my property during reasonable hours to inspect the area to which the application applies.</li> <li>The applicant shall provide a minimum of ten (10) sets of three (3) photographs in support of this application as follows: at least one (1) picture of the front of the property and at least two photos (from different angles) of the specific area of the property to which the application applies.</li> </ul>	
APPLICANTS SIGNATURE	OWNER'S SIGNATURE <i>Mark Adams</i>
<input checked="" type="checkbox"/> VARIANCE <input type="checkbox"/> SPECIAL EXCEPTION <input type="checkbox"/> OTHER	P&Z CASE NUMBER 2023 09 028            DATE OF HEARING 11/28

**Sec. 42-64. - Variances.** The Board shall have the power to approve, conditionally approve or deny applications for a variance from the terms of the Land Development Code.

Criteria. The Board shall not approve an application for a variance from terms of the Land Development Code unless and until:

- A written application for a variance is submitted to the city manager or the city manager's designee on a form provided by the city clerk setting forth all of the special conditions and circumstances that exist in favor of the granting of the variance and addressing the requirements of subsections (1)d—g of this section of the criteria set forth in this section. Upon submission of the properly completed application and the appropriate fee, the city manager or the city manager's designee shall refer the application to the board.

- Notice of public hearing for the variance shall be given as required by the article for hearing before the board.
- The public hearing on the application for the variance shall be held. The applicant, the applicant's agent as evidenced by a signed writing or the applicant's attorney shall appear before the board.
- It is determined that literal enforcement of the provisions of the zoning ordinances would result in unnecessary hardship and that said hardship is created by special conditions and circumstances peculiar to the land, structure or building involved, including but not limited to dimensions, topography or soil conditions.
- It has been determined that personal hardship is not being considered as grounds for a variance since the variance will continue to affect the character of the neighborhood after title to the property has passed and that the special conditions and circumstances were not created in order to circumvent the Land



Development Code or for the purpose of obtaining a variance.

- f. It is determined that the variance is the minimum variance that will make possible the reasonable use of the land, building or structure.
- g. It is determined that the granting of the variance will be in harmony with the general purpose and intent of the Land Development Code, will not be injurious to the neighborhood, will not be detrimental to the public welfare, and will not be contrary to the public interest.
- h. The board shall find that the preceding requirements have been met by the applicant for a variance.

The Board shall find that the preceding requirements have been met by the applicant for a variance.

*(2) Violations of conditions.*

- a. In granting any variance, the Board may prescribe appropriate conditions and safeguards to comply with the Land Development Code. Violation of such conditions and safeguards, when made a part of the terms under which

the variance is granted, shall be deemed a violation of this Land Development Code and punishable in accordance with this article. At the Board's discretion, such variance may be revoked for violation of the condition and safeguards.

- b. The Board may prescribe a reasonable time limit within which the action for which the variance is required shall be begun or completed. Under no circumstances, except as permitted above, shall the Board grant a variance to allow a use not generally or by special exception allowed in the zoning district involved, or any use expressly or by implication prohibited by the terms of the Land Development Code in the zoning district. No nonconforming use of neighboring lands, structures, or buildings in the same zoning district, and no permitted use of land, structures, or buildings in other zoning districts, shall be considered grounds for the authorization of a variance.

**Applications submitted must meet all of the above criteria before the Board can grant a variance.** The burden of proof is on the applicant to comply with the criteria.

A special exception addresses the compatibility of uses, differing slightly from a variance. The approval of a special exception depends on how the request affects the surrounding area. All uses allowed as special exceptions are listed within the individual zoning districts. Before the Board can approve a special exception, the request must meet all of the following criteria:

1. A written application for a special exception must be submitted to City Hall no later than 4:00 p.m. on the first Thursday of the previous month. (See Above)
2. The Board shall find that it is empowered under the section of the zoning ordinance described in the application to grant the special exception and that granting the special exception will not adversely affect the public interest.
3. It is determined that public health, safety, comfort, order, convenience, prosperity, morals, or general welfare is promoted, protected, or improved.

**General Information**

1. Certain conditions may be prescribed on the special exception or variance approved by the Board.
2. *The applicant must be present at all hearings.*
3. Decisions rendered by the Board do not become final until fifteen (15) days after the hearing. The fifteen-day waiting period allows all aggrieved parties to appeal the decision. Any person filing an appeal will submit, within fifteen (15) days of the decision, a notice stating where they feel the Planning and Zoning Board erred in their decision. Belle Isle's City Council will then hold an appeal hearing.
4. Sec 42-61 thru 41-72 - Variances and special exceptions granted by the Board will become void if a permit necessary for utilization of the variance or special exception is not issued within six (6) months of the date approved by the Planning and Zoning Board.

FOR OFFICE USE ONLY:  
**FEE: \$300**

\_\_\_\_\_ Date Paid

\_\_\_\_\_ Check/Cash

\_\_\_\_\_ Rec'd By

To: Whom it may concern,

My request is for variance of 50-102 (a) (1) sentence 5 part (and of like materials). My principal building is block construction and this part of sec 50-102 (a) (1) sentence 5 (and of like materials) causes unnecessary financial hardship. A block-built garage that will cost me 454% more when a metal garage that is architecturally similar serving the same purpose could be built. There are many residences in Belle Isle that have the principal building is of other materials that have a metal garage that is architecturally similar. I have investigated building with (of like materials) and the cost being four and half times more expensive to have the same outcome (architecturally similar) would be an unnecessary financial hardship and an unnecessary financial burden to me as a homeowner in Belle Isle. There will be no difference in effects due to this variance to adjacent properties or surrounding neighborhood as the variance I am asking for is for the (of like materials) to be varied for a metal garage.

Thank you,

A handwritten signature in black ink, appearing to read 'Mark Adams', with a long horizontal flourish extending to the right.

Mark Adams

Prepared by/ Return to:  
Shannon Partin  
Magnolia Title  
2727 13th Street, St. Cloud, FL 34769  
6030000228

as a necessary incident to the fulfillment of conditions  
contained in a title insurance commitment issued by it.

Property Appraisers Parcel I.D. (Folio) Number(s): 29-23-30-4389-03-040

**WARRANTY DEED**

This Warranty Deed Made the 17 day of February, 2023, by Deborah L. Kenney, a married woman, Michael L. Emery, a single man, Louis T. Emery, a married man, and Patricia K. Szirotnyak, hereinafter called the grantor, whose post office address is: 6909 Barby Lane, Belle Isle, FL 32812 to Mark F. Adams and Margaret V. Adams, husband and wife, whose post office address is: 3104 Indian Drive, Belle Isle, FL 32812, hereinafter called the grantee,

WITNESSETH: That said grantor, for and in consideration of the sum of \$350,000.00 (THREE HUNDRED FIFTY THOUSAND AND 00/100) and other valuable considerations, receipt whereof is hereby acknowledged, hereby grants, bargains, sells, aliens, remises, releases, conveys and confirms unto the grantee, all that certain land situate in ORANGE County, Florida, viz:

Lot 4, Block C, LAKE CONWAY PARK, according to the plat thereof, as recorded in Plat Book G, Page(s) 138, of the Public Records of Orange County, Florida.

The Subject property is not the homestead of the Grantor under the Laws and Constitution of the State of Florida, in that neither Grantor or any members of the household of Grantor reside thereon.

TOGETHER with all the tenements, hereditaments and appurtenances thereto belonging or in anywise appertaining. To Have and to Hold, the same in fee simple forever.

And the grantor hereby covenants with said grantee that the grantor is lawfully seized of said land in fee simple; that the grantor has good right and lawful authority to sell and convey said land; that the grantor hereby fully warrants the title to said land and will defend the same against the lawful claims of all persons whomsoever; and that said land is free of all encumbrances, except taxes accruing subsequent to December 31, 2022, reservations, restrictions and easements of record, if any.

(The terms "grantor" and "grantee" herein shall be construed to include all genders and singular or plural as the context indicates.)

In Witness Whereof, Grantor has hereunto set grantor's hand and seal the day and year first above written.

**SIGNED IN THE PRESENCE OF THE FOLLOWING WITNESSES  
(TWO SEPARATE DISINTERESTED WITNESSES REQUIRED)**

Witness 1 Signature: [Signature]  
Witness 1 Printed Name: Shannon Partin

[Signature]  
Deborah L. Kenney

Witness 2 Signature: [Signature]  
Witness 2 Printed Name: Nelida Rivera

[Signature]  
Michael L. Emery

STATE OF Florida  
COUNTY OF Osceola

The foregoing instrument was acknowledged before me by means of  physical presence or  online notarization this 10 day of February, 2023 by Deborah L. Kenney, a married woman, Michael L. Emery, a single man, who has/have produced drivers license as identification.

[Signature]  
Notary Public Signature  
Printed Name: Shannon Partin

My Commission Expires: \_\_\_\_\_ (SEAL)

**SIGNED IN THE PRESENCE OF THE FOLLOWING WITNESSES  
(TWO SEPARATE DISINTERESTED WITNESSES REQUIRED)**

Witness 1 Signature: [Signature]  
Witness 1 Printed Name: Shannon Partin

[Signature]  
Louis T. Emery

Witness 2 Signature: [Signature]  
Witness 2 Printed Name: Nelida Rivera

STATE OF Florida  
COUNTY OF Osceola

The foregoing instrument was acknowledged before me by means of  physical presence or  online notarization  
this 15 day of February, 2023 by Louis T. Emery, a married man, who has/have produced  
driver's license as identification.

[Signature]

My Commission Expires: \_\_\_\_\_ (SEAL)

Notary Public Signature  
Printed Name: Shannon Partin

Online Notary (Check Box if acknowledgment done by Online Notarization)

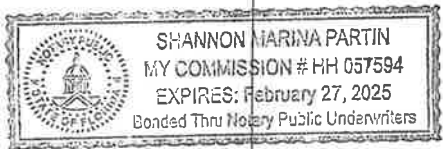

**SIGNED IN THE PRESENCE OF THE FOLLOWING WITNESSES  
(TWO SEPARATE DISINTERESTED WITNESSES REQUIRED)**

Witness 1 Signature: Karla Fresia  
Witness 1 Printed Name: Karla Fresia

Patricia K. Szirotnyak  
Patricia K. Szirotnyak

Witness 2 Signature: Tanner Ott  
Witness 2 Printed Name: Tanner Ott

STATE OF Arkansas  
COUNTY OF Marion

The foregoing instrument was acknowledged before me by means of  physical presence or  online notarization  
this 14th day of February, 2023 by Patricia K. Szirotnyak, who has/have produced  
Arkansas D.L. as identification.

David R Drake  
Notary Public Signature  
Printed Name:

My Commission Expires: 10/25/30  
(SEAL)

Online Notary (Check Box if acknowledgment done by Online Notarization)

DAVID R DRAKE  
MARION COUNTY  
NOTARY PUBLIC – ARKANSAS  
My Commission Expires October 25, 2030  
Commission No. 12378881





City of Belle Isle  
 Universal Engineering Sciences 3532 Maggie Blvd., Orlando, FL 32811  
 Tel 407-581-8161 \* Fax 407-581-0313 \* [www.universalengineering.com](http://www.universalengineering.com)

REC-10-2023

**Building Permit (Land Use) Application**  
 To be completed as required by State Statute Section 713 and other applicable sections.

PERMIT # 2023-08-030

Owner's Name Mark Adams  
 Owner's Address 3104 Indian Dr. Belle Isle FL 32812

Contractor Name <u>Marcus Adams</u>	Company Name <u>N/A</u>
License # <u>N/A</u>	Company Address <u>N/A</u>
Contact Phone/Cell <u>407-435-4930</u>	City, State, ZIP <u>N/A</u>
Contact Email <u>MFA 4533@aol.com</u>	Contact Fax <u>N/A</u>

**WARNING TO OWNER:** Your failure to record a Notice of Commencement may result in your paying twice for improvements to your property. A notice of commencement must be recorded if job is \$2500(+) or if A/C Replacement \$7500(+) and posted on the job site before the first inspection. If you intend to obtain financing, consult with your lender or an attorney before recording your Notice of Commencement.

I hereby make Application for Permit as outlined above, and if same is granted I agree to conform to all Division of Building Safety Regulations ([www.floridabuilding.org](http://www.floridabuilding.org)) and City Ordinances ([www.municode.com](http://www.municode.com)) regulating same and in accordance with plans submitted. The issuance of this permit does not grant permission to violate any applicable City and/or State of Florida codes and for ordinances. Application is hereby made to obtain a permit to do the work and installations as indicated. I certify that no work or installation has commenced prior to the issuance of a permit and that all work will be performed to meet the standards of all laws regulating construction in this jurisdiction. I understand that a separate permit must be secured for all other construction including ROOFING, ELECTRICAL, MECHANICAL, PLUMBING, GAS, SIGNS, POOLS, SCREEN ENCLOSURES, ETC.

**OWNER'S AFFIDAVIT:** I certify that all the foregoing information is accurate and that all work will be done in compliance with all applicable laws regulating construction and zoning.

**Owner Signature** [Signature]  
 The foregoing instrument was acknowledged before me this 10 August 2023  
 by MARCUS F. ADAMS who is personally known to me  
 and who produced A 352 546 71 137 0  
 as identification and who did not take an oath.  
 Notary as to Owner  
 State of Florida  
 County of Orange



**Contractor Signature** \_\_\_\_\_  
 COMPANY NAME \_\_\_\_\_  
 The foregoing instrument was acknowledged before me this 1 / 1  
 by \_\_\_\_\_ who is personally known to me  
 and who produced \_\_\_\_\_  
 as identification and who did not take an oath.  
 Notary as to Owner  
 State of Florida  
 County of Orange

**Impervious Surface Ratio Worksheet**  
 Development Zoned A-1 A-2, R-1-AAA, R-1-AA, R-1-A, R-1 per City Code, Section 50-74: Impervious Surface Ratio

- Total Lot Area (sqft) X 0.35 = Allowable Impervious Area (BASE).  
 Total Lot Area 15080 X 0.35 =  
 Allowable Impervious Area (BASE) 5278
- Calculate the "proposed" impervious area on the lot. This includes the sum of all areas that do not allow direct percolation of rainwater. Examples include house, pool, deck, driveway, accessory building, etc.
  - House 1520
  - Driveway 664
  - Walkway 144
  - Accessory Buildings 546
  - Pool & Spa \_\_\_\_\_
  - Deck & Patio 1436.62
  - Other \_\_\_\_\_
 Actual Impervious Area (AIA) 3764.62 - 4310.62
- If AIA is less than BASE, subtract AIA from BASE to determine the amount of impervious area that may be added without providing onsite retention.
- If AIA is greater than BASE, then onsite retention must be provided.

Assuming 7.5 inches of rainfall based on a 24hr 10 year Rain Event (TP40), the formula is: (7.5 inches rainfall/12 inches p/foot) X (result from line 4) = cubic feet of storage volume needed



2023.08.030

Sheet 1 of 2 (Sketch of Survey) - See Sheet 2 of 2 for Legal Description, Certifications, Property and other Survey related data. SURVEY IS NOT COMPLETE WITHOUT ALL SHEETS



SCALE: 1"=40'

BEARING REFERENCE:  
NONE. RECORD INFORMATION RELIANT UPON ANGULAR DATA ONLY.  
ALL ANGULAR DATA SHOWN HEREON REFERENCED THERETO.



AERIAL PHOTOGRAPH  
(DO NOT SHOW LATEST IMPROVEMENTS)

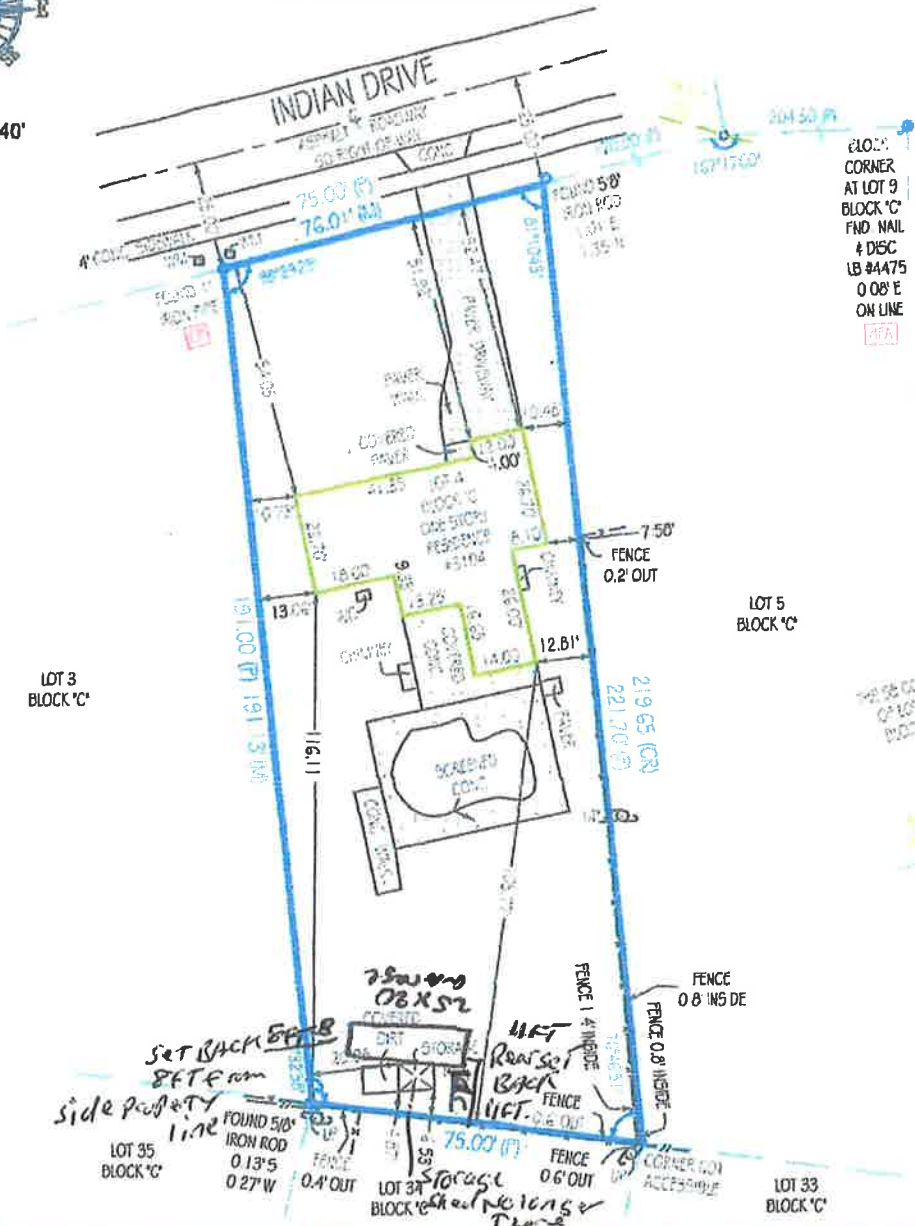

210.2' CORNER AT LOT 9 BLOCK 'C' FND NAIL & DISC LB #4475 0 08' E ON LINE

436 10 2023

THE SW CORNER OF PARCEL ID: 29-23-30-4369-01-150 FOUND 5/8" IRON ROD 0.15' E 0.96' S



'CP' = CONTROLLING POINT (POINT OF ROTATION) 'HFA' = HELD FOR ALIGNMENT - ALL OTHER MONUMENTATION AND IMPROVEMENTS RELATIVE THERETO  
Platted Easements, Notable or Adverse Conditions (unplatted easements also listed if provided by client): IF APPLICABLE, RECIPIENTS OF THIS SURVEY SHOULD REVIEW THE POSITION OF ANY FENCE LINES SHOWN HEREON AND THEIR RELATIONSHIP TO THE BOUNDARY LINE  
- NO NOTABLE CONDITIONS FOUND.

This survey has been issued by the following Landtec Surveying office:  
700 West Hillsboro Boulevard, Suite 4-100  
Deerfield Beach, FL 33441  
Office: (561) 367-3587  
Fax: (561) 465-3145  
[www.Landtecsurvey.com](http://www.Landtecsurvey.com)

Elevations, if shown:  
Benchmark: \_\_\_\_\_  
Benchmark Elev.: \_\_\_\_\_  
Benchmark Datum: \_\_\_\_\_  
Elevations on Drawing are in:  
N.G.V.D.29  N.A.V.D.88

Revisions:

Job Nr: 163615-CE Date of Field Work: 02/10/2023 Drawn by: V. M.



**TYPE OF SURVEY:**

- BOUNDARY       CONSTRUCTION       CONDOMINIUM  
 ALTA/NSPS       TOPOGRAPHIC       SPECIAL PURPOSE

**PURPOSE OF SURVEY (SEE GENERAL NOTES BELOW):**

Purchase/Refinance

**LEGAL DESCRIPTION:**

Lot 4, Block C, LAKE CONWAY PARK, according to the plat thereof, as recorded in Plat Book G, Page(s) 138, of the Public Records of Orange County, Florida

**PROPERTY ADDRESS:**

3104 INDIAN DRIVE  
BELLE ISLE, FL 32812

INVOICE NUMBER: 163615-CE

DATE OF FIELD WORK: 02/10/2023

CLIENT FILE: 6030000228

**CERTIFIED TO**

MAGNOLIA TITLE  
AGENTS NATIONAL TITLE INSURANCE COMPANY  
MARK F. ADAMS AND MARGARET V. ADAMS

FLOOD ZONE: X

FLOOD MAP: 112095C

PANEL: 0430

SUFFIX: F

PANEL DATE: 09/25/2009



**PLATTED EASEMENTS, NOTABLE OR ADVERSE CONDITIONS (UNPLATTED EASEMENTS ALSO LISTED IF PROVIDED BY CLIENT):**  
**IF APPLICABLE, RECIPIENTS OF THIS SURVEY SHOULD REVIEW THE POSITION OF ANY FENCE LINES SHOWN HEREON AND THEIR RELATIONSHIP TO THE BOUNDARY LINE.**

**ABBREVIATION LEGEND (SOME ITEMS IN LEGEND MAY NOT APPEAR ON DRAWING)**

A OR AL = ARC LENGTH	BU = ELECTROMETER	P = PLAT	QTR = QUARTER
CA = CLEARCUT	FFE = FINISHED FLOOR ELEV.	PC = POINT OF CURVE	R = RADUS
CAV = CENTRAL ANGLE	FIR = FOUNDATION	PCO = POINT OF COMPOUND CURVE	RNG = RANGE
CAVY = CABLE TYPUSER	FN = FOUNDN	PH = POOL HEATER	SEC = SECTION
CF = CALCULATED FROM FIELD	FND = FOND	PI = POINT OF INTERSECTION	TR = TELEPHONE RISER
CH = CHORD DISTANCE	Q.F.F. = GARAGE FINISHED FLOOR	POB = POINT OF BEGINNING	TWP = TOWNSHIP
CONC = CONCRETE	Q.F.F. = GARAGE FINISHED FLOOR	POC = POINT OF COMMENCEMENT	UE = UTILITY EASEMENT
CR = CALCULATED FROM RECORD	L = LEGAL DESCRIPTION	PP = POOL PUMP	UP = UTILITY POLE
DE = DRAINAGE EASEMENT	M = MEASURED	PRC = POINT OF REVERSE CURVE	WM = WATER METER
EL OR ELEV = ELEVATION	DNG = OVERHEAD CABLE	PT = POINT OF TANGENCY	WV = WATER VALVE

**SYMBOLS (SOME ITEMS IN LEGEND MAY NOT APPEAR ON DRAWING - NOT TO SCALE)**

UP = UTILITY POLE	W = WELL	HP = HANDICAP PARKING SPACE
LP = LIGHT POLE	CL = CENTER LINE	
CB = CATCH BASIN	PW = PARTY WALL	
FH = FIRE HYDRANT	AC = AIR CONDITIONER	SC = SEC. QTR. CORNER
MH = MANHOLE	SL = SEPTIC LID	SC = SECTION CORNER
WM = WATER METER	X = ELEV. SHOT	
WV = WATER VALVE		

**LINETYPES:**

BOUNDARY	—————
BUILDING	—————
EASEMENT	—————
CHAIN LINK FENCE	—————
WOOD FENCE	—————
PLASTIC FENCE	—————
OVERHEAD CABLE	—————

**GENERAL NOTES:**

- THIS SURVEY IS BASED UPON RECORD INFORMATION PROVIDED BY CLIENT. NO SPECIFIC SEARCH OF THE PUBLIC RECORD HAS BEEN MADE BY THIS OFFICE UNLESS OTHERWISE NOTED.
- AS INDICATED ABOVE, UNDER "PURPOSE OF SURVEY", IF THIS SURVEY HAS BEEN PREPARED FOR A PURCHASE OR REFINANCE, ITS SCOPE IS LIMITED TO THE DETERMINATION OF TITLE DEFICIENCIES, AND IS NOT INTENDED FOR USE IN DESIGN OR CONSTRUCTION PURPOSES. RECIPIENTS MUST CONTACT OUR OFFICE FOR APPROVAL PRIOR TO SUCH USE. LANDTEC SURVEYING ASSUMES NO RESPONSIBILITIES FOR ERRORS RESULTING FROM FAILURE TO ADHERE TO THIS CLAUSE.
- ANY FENCES SHOWN HEREON ARE ILLUSTRATIVE OF THEIR GENERAL POSITION ONLY. FENCE TIES SHOWN ARE TO GENERAL CENTERLINE OF FENCE. THIS OFFICE WILL NOT BE RESPONSIBLE FOR DAMAGES RESULTING FROM THE REMOVAL OF, OR CHANGES MADE TO, ANY FENCES UNLESS WE HAVE PROVIDED A SURVEY SPECIFICALLY LOCATING SAID FENCES FOR SUCH PURPOSES. DETERMINATION OF FENCE POSITIONS SHOULD BE BASED SOLELY ON THEIR PHYSICAL RELATIONSHIP TO THE MONUMENTED BOUNDARY LINES.
- GRAPHIC REPRESENTATIONS MAY HAVE BEEN EXAGGERATED TO MORE CLEARLY ILLUSTRATE MEASURED RELATIONSHIPS - DIMENSIONS SHALL HAVE PRECEDENCE OVER SCALED POSITIONS.
- UNDERGROUND IMPROVEMENTS HAVE NOT BEEN LOCATED EXCEPT AS SPECIFICALLY SHOWN.
- ELEVATIONS ARE BASED UPON NATIONAL GEODETIC VERTICAL DATUM (N.G.V.D. 1929) OR NORTH AMERICAN VERTICAL DATUM (N.A.V.D. 1885) AS SHOWN ON SHEET 1.
- ALL BOUNDARY AND CONTROL DIMENSIONS SHOWN ARE FIELD MEASURED AND CORRESPOND TO RECORD INFORMATION UNLESS SPECIFICALLY NOTED OTHERWISE.
- ANY CORNERS SHOWN AS "SET" HAVE EITHER BEEN SET ON THE DATE OF FIELD WORK, OR WILL BE SET WITHIN 2 BUSINESS WEEKS OF SAID DATE AND ARE IDENTIFIED WITH A CAP MARKED LS (LICENSED SURVEYOR) #7274.

I HEREBY CERTIFY THAT THIS SURVEY MEETS THE STANDARDS OF PRACTICE AS OUTLINED IN CHAPTER 61-17.051 & 61-17.062 OF THE FLORIDA ADMINISTRATIVE CODE, PURSUANT TO SECTION 472.027, FLORIDA STATUTES, AND THAT THE ELECTRONIC SIGNATURE AND SEAL HEREON MEETS PROCEDURES AS SET FORTH IN CHAPTER 61-17.062, PURSUANT TO SECTION 472.025, FLORIDA STATUTES.



Digitally signed  
by Pablo Alvarez  
Date: 2023.02.13  
14:09:43 -05'00'      DATE: 02/13/2023

SIGNATURE: PABLO A. ALVAREZ - PROFESSIONAL SURVEYOR AND MAPPER  
FLORIDA REGISTRATION NO. 7274 (NOT VALID WITHOUT THE SIGNATURE AND ORIGINAL RAISED SEAL OR THE ELECTRONIC SEAL OF THE FLORIDA LICENSED SURVEYOR AND MAPPER SHOWN ABOVE)

**PRINTING INSTRUCTIONS:**

WHEN PRINTING THIS PDF IN ADOBE, SELECT "ACTUAL SIZE" TO ENSURE CORRECT SCALING. DO NOT USE "FIT".



LICENSED BUSINESS No. 8507









**APPROVED PRODUCTS LIST**

PRODUCT CATEGORY	SUB CATEGORY	MANUFACTURER	APPROVAL No. & DATE
STRUCTURAL COMPONENTS	ROOF DECK	CAROLINA CARPORTS, INC 26 Gauge AG Panel	FL6596 1-R6 12/15/20
STRUCTURAL COMPONENTS	STRUCTURAL WALL	CAROLINA CARPORTS, INC 26 Gauge AG Panel	FL6702 1-R6 12/15/20
EXTERIOR DOORS	SWINGING	ELIXIR DOOR AND METAL COMPANY Series 407	FL17996 5-R2 02/28/21
EXTERIOR DOORS	ROLL-UP	CAROLINA CARPORTS, INC. Steel Roll-Up Sheet Door - (16' Max. Width)	FL16806 3-R5 12/16/20

METAL FRAMING AND SIDING PREFABRICATED BY CAROLINA CARPORTS, INC. P.O. BOX 1263 DOBSON, NORTH CAROLINA 27017

THESE ENGINEERING DRAWINGS ARE THE PROPERTY OF BECHTOL ENGINEERING & TESTING, INC AND CAROLINA CARPORTS, INC. THESE DRAWING MAY NOT BE REPRODUCED WITHOUT THE WRITTEN CONSENT OF BECHTOL ENGINEERING & TESTING, INC., AND CAROLINA CARPORTS, INC.

THIS IS TO CERTIFY THAT THE CALCULATIONS AND SPECIFICATIONS HEREIN HAVE BEEN PREPARED BY THE UNDERSIGNED PROFESSIONAL ENGINEER, AND ARE IN ACCORDANCE WITH THE REQUIREMENTS OF SECTION 1609 OF THE FLORIDA BUILDING CODE, SEVENTH EDITION (2020)

**GENERAL NOTES:**

- THESE PLANS PERTAIN ONLY TO THE STRUCTURE, INCLUDING MAIN WIND FORCE RESISTING SYSTEM, COMPONENTS AND CLADDING, AND BASE RAIL ANCHORAGE. OTHER DESIGN ISSUES, INCLUDING BUT NOT LIMITED TO PLUMBING, ELECTRICAL, INGRESS/EGRESS, PROPERTY SET-BACKS, FINISH FLOOR ELEVATION AND SLOPE, OR OTHER LOCAL ZONING REQUIREMENTS ARE THE RESPONSIBILITY OF OTHERS.
- THESE STRUCTURES ARE DESIGNED AS NON-HABITABLE UTILITY / STORAGE BUILDINGS (RISK CATEGORY I) CAPABLE OF SUPPORTING DEAD LOAD OF THE STRUCTURE AND APPLICABLE LIVE AND WIND LOADS. IMPROVEMENTS NOT SPECIFICALLY ADDRESSED HEREIN, INCLUDING DOORS, WINDOWS, SOLAR PANELS, LIGHTING, INTERIOR WALL(S), CEILING FIXTURES, OR OTHER COMPONENTS NOT LISTED IN THE FBC APPROVED PRODUCTS LIST (THIS SHEET), AND NOT PROVIDED AND INSTALLED BY CAROLINA CARPORTS, INC., WHICH EXERT ADDITIONAL LOADS ON THE STRUCTURE SHALL BE AT THE OWNER'S RISK. BECHTOL ENGINEERING AND TESTING, INC., SHALL NOT BE RESPONSIBLE FOR STRUCTURAL DAMAGE OR FAILURE DUE TO THE APPLICATION OF ADDITIONAL LOADS.
- ALL STEEL TUBING SHALL BE 50 KSI GALVANIZED STEEL. ALL FASTENERS SHALL BE GALVANIZED OR STAINLESS STEEL.
- ALL COMPONENTS AND CLADDING SHALL BE INSTALLED ACCORDING TO MANUFACTURER'S INSTALLATION INSTRUCTIONS.
- ALL FIELD FRAMING CONNECTIONS SHALL BE #12-14 x 3/4" SELF DRILLING SCREWS WITHOUT CONTROL SEAL WASHER. ALL SHOP FRAMING CONNECTIONS SHALL BE WELDED.
- CONCRETE SHALL HAVE A MINIMUM COMPRESSIVE STRENGTH OF 2500 PSI AT 28 DAYS. THE REINFORCING STEEL SHALL BE MINIMUM GRADE 40. CONCRETE SLAB FOUNDATIONS SHALL BE REINFORCED WITH 6x6 - W1.4xW1.4 WELDED WIRE FABRIC COMPLYING WITH ASTM A 185, OR WITH SYNTHETIC FIBER REINFORCEMENT COMPLYING WITH ASTM C1116.
- CONCRETE ANCHORS SHALL BE TAPCON REDHEAD LDT 1/2" x 5" OR EQUIVALENT.
- POST/RAFTER BRACING: BRACE ON EVERY POST/RAFTER CONNECTION, EXCEPT FOR END WALLS AND GABLE ENDS.
- SLAB FOUNDATION SUBGRADE SOILS SHALL BE TERMITE TREATED AND COVERED WITH 6 MIL VAPOR RETARDER PER SECTION R318.1 OF THE FLORIDA BUILDING CODE SEVENTH EDITION (2020) - RESIDENTIAL, AND SECTION 1816.1 OF THE FLORIDA BUILDING CODE SEVENTH EDITION (2020) - BUILDING. SOIL LOAD BEARING PRESSURE OF 2000PSF IS ASSUMED.
- 14 GA FRAMING: 2-1/2" x 2-1/2" TUBE STEEL (TS) WITH 2-1/4" x 2-1/4" TS NIPPLES.  
12 GA FRAMING: 2-1/4" x 2-1/4" TS WITH 2" x 2" TS NIPPLES.
- FOR ROOF SLOPES LESS THAN 7 DEGREES, SEAL ALL PANEL OVERLAPS WITH BUTYL TAPE OR OTHER SUITABLE SEALANT.
- FOR CONTINUOUS REINFORCING, MINIMUM BAR OVERLAP SHALL BE 40 BARS DIAMETERS ( 25" FOR #5 REBAR)

OCCUPANCY GROUP	U
CONSTRUCTION TYPE	II-B
RISK CATEGORY	I
BUILDING ENCLOSURE TYPE:	ENCLOSED
WIND EXPOSURE CATEGORY:	D
ULTIMATE WIND SPEED (MPH)	130
NOMINAL DESIGN WIND SPEED (MPH):	101
MEAN ROOF HEIGHT (FEET):	11.25
ROOF ANGLE (DEGREES):	14.0
INTERNAL PRESSURE COEFFICIENT:	+0.18 / -0.18
DESIGN PRESSURES (PSF):	
ROOF:	
ZONE 1:	+16.0 / -30.2
ZONE 2e:	+16.0 / -30.2
ZONE 2n:	+16.0 / -49.7
ZONE 2r:	+16.0 / -49.7
ZONE 3e:	+16.0 / -49.7
ZONE 3r:	+16.0 / -57.5
WALLS:	
ZONE 4:	+24.1 / -26.4
ZONE 5:	+24.1 / -30.4
SWINGING DOOR:	+25.7 / -33.6
ROLL-UP DOOR:	+22.4 / -24.7

NOTE: 14 GA FRAMING

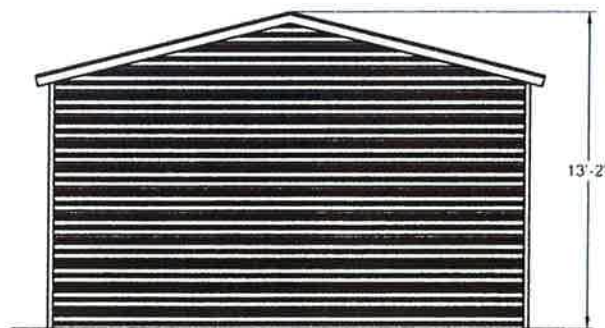

FRONT ELEVATION

SCALE: 1/8" = 1'

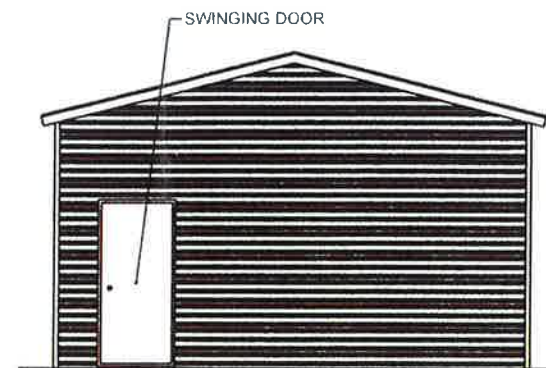

REAR ELEVATION

SCALE: 1/8" = 1'

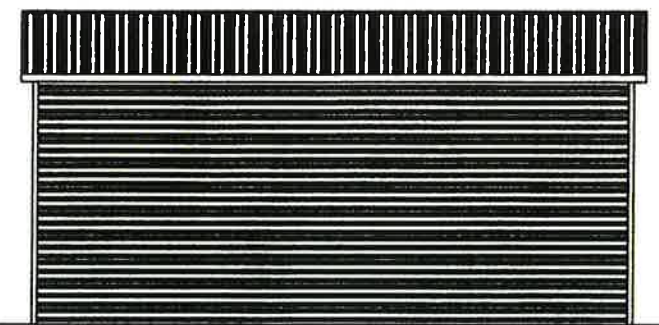

LEFT SIDE ELEVATION

SCALE: 1/8" = 1'

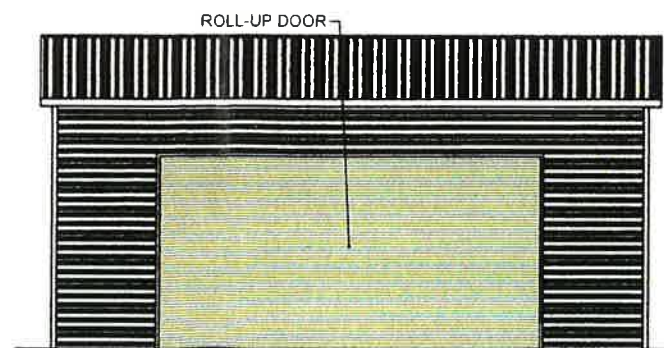

RIGHT SIDE ELEVATION

SCALE: 1/8" = 1'



PROPOSED UTILITY STRUCTURE  
**3104 INDIAN DRIVE**  
 BELLE ISLE, ORANGE COUNTY, FLORIDA

**BECHTOL ENGINEERING AND TESTING, inc.**  
 CONSULTING GEOTECHNICAL, ENVIRONMENTAL AND MATERIALS TESTING ENGINEERS  
 Certificate of Authorization No. 00002402

FIELD	DATE
DESIGN ZS	05/23/2023
CHECKED CS/LP	SCALE NTS
APPROVED ZS/LP	SHEET NO G23001
	SHEET 1 OF 3



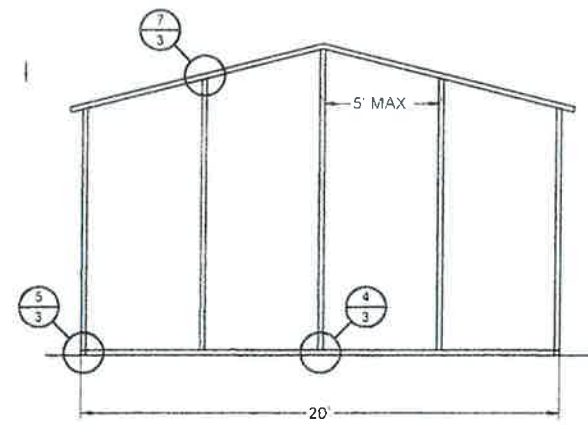

FRONT POST/RAFTER FRAMING PLAN

SCALE 1/8" = 1'

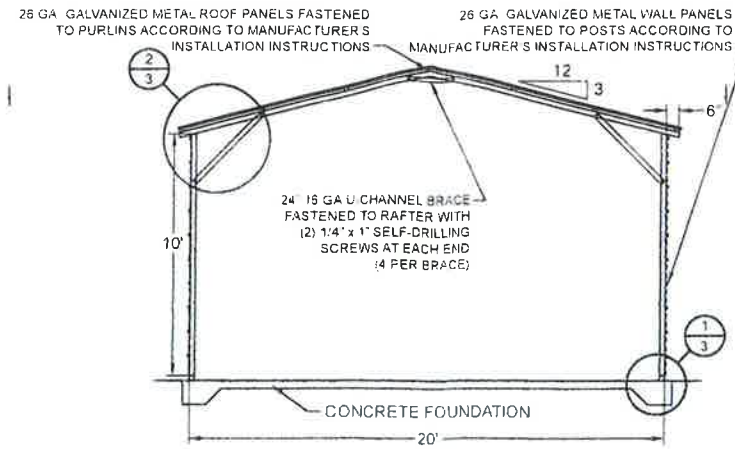

TYPICAL INTERIOR POST/RAFTER FRAMING SECTION (FRONT VIEW)

SCALE 1/8" = 1'

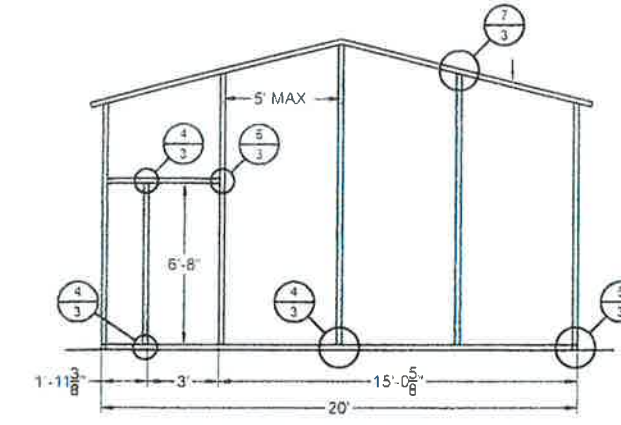

REAR POST/RAFTER FRAMING PLAN

SCALE 1/8" = 1'

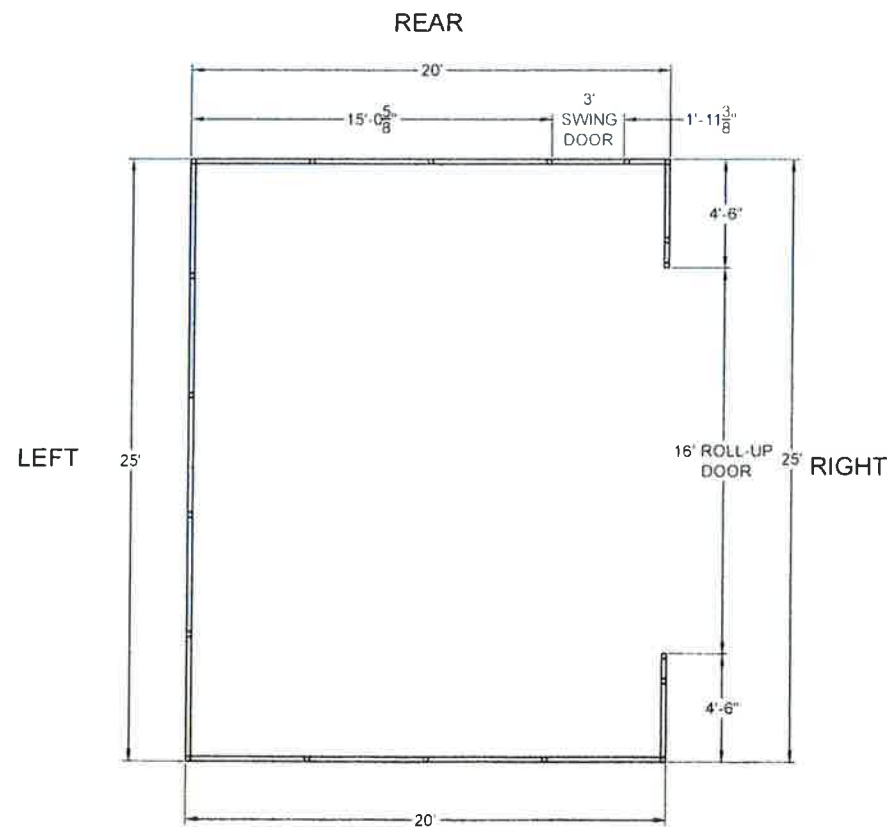

BASE RAIL LAYOUT

SCALE 1/8" = 1'

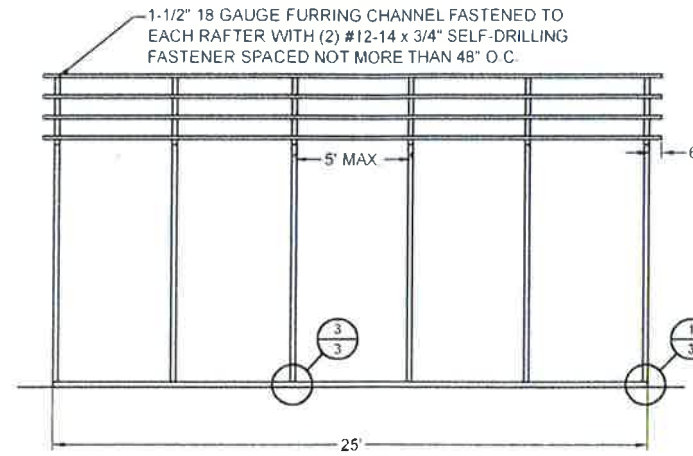

LEFT SIDE POST/RAFTER FRAMING PLAN

SCALE 1/8" = 1'

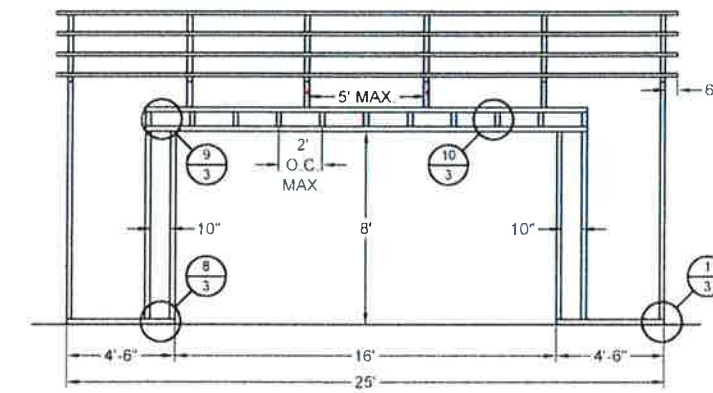

RIGHT SIDE POST/RAFTER FRAMING PLAN

SCALE 1/8" = 1'



16 GAUGE U-CHANNEL BRACE FASTENED TO THE POST AND RAFTER WITH (2) #12-14 x 3/4" SDF'S AT EACH END (4 PER BRACE)

BRACE SECTION

Not To Scale



BECHTOL ENGINEERING AND TESTING, INC. 88538  
605 WEST NEW YORK AVENUE  
DELAND FLORIDA 32720

PROPOSED UTILITY STRUCTURE  
**3104 INDIAN DRIVE**  
BELLE ISLE, ORANGE COUNTY, FLORIDA



BECHTOL ENGINEERING AND TESTING, inc.

CONSULTING GEOTECHNICAL, ENVIRONMENTAL, AND MATERIALS TESTING ENGINEERS  
Certificate of Authorization No. 00005492

FIELD	DATE	05/23/2023
DESIGN	SCALE	NTS
DRAWN	DATE	G23001
APPROVED	SCALE	SHEET 2 OF 3

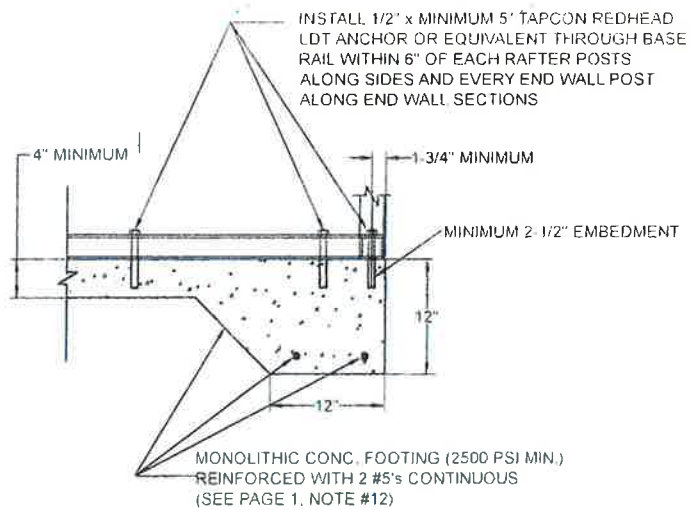

**1 CONCRETE BASE RAIL ANCHORAGE**  
Not To Scale

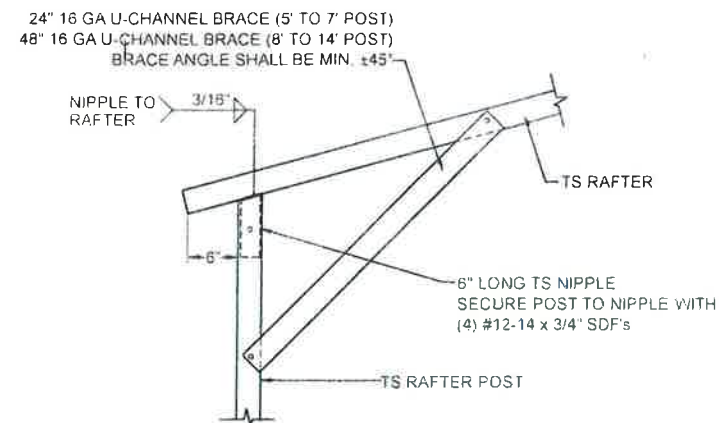

**2 BOX EAVE RAFTER/POST DETAIL REAR**  
Not To Scale

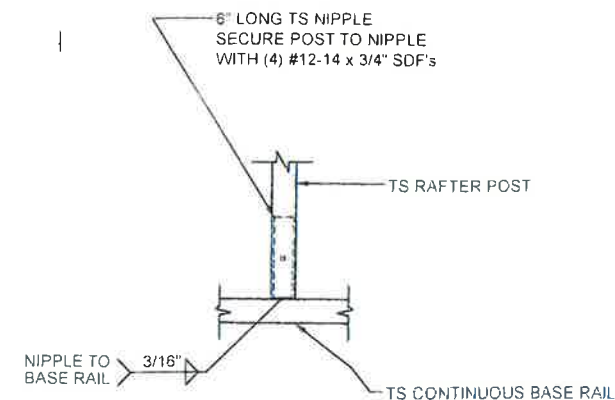

**3 POST/BASE RAIL CONN. DETAIL**  
Not To Scale

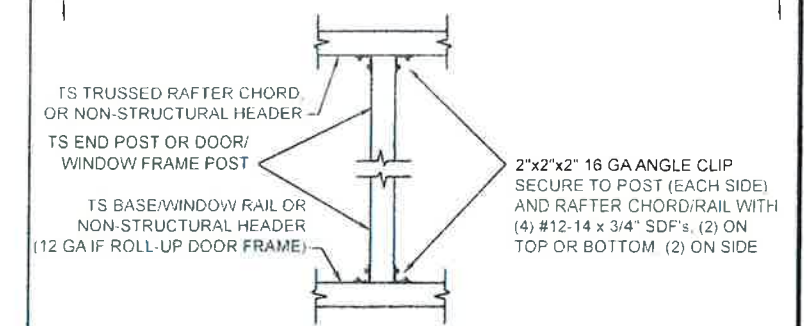

**4 POST TO RAIL, TRUSS CHORD, OR NON-STRUCTURAL HEADER CONN. DETAIL**  
Not To Scale

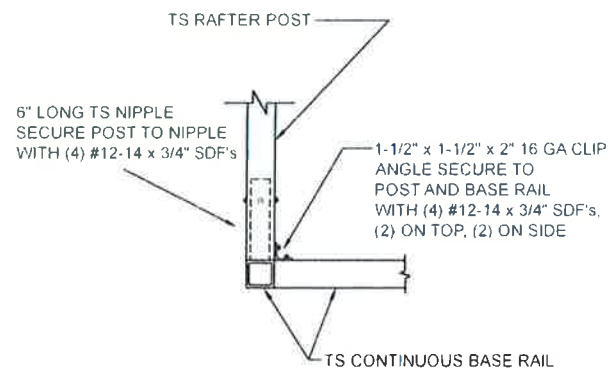

**5 END POST/BASE RAIL CONN.**  
Not To Scale

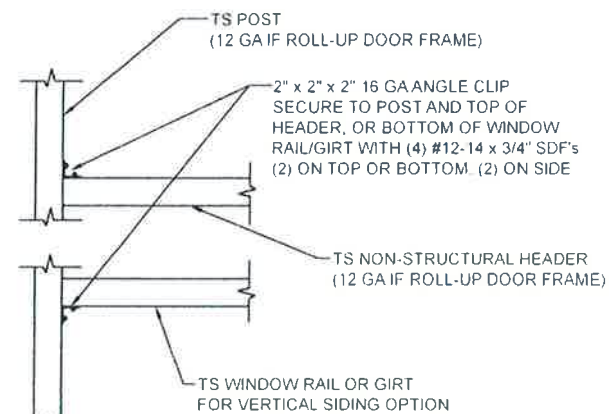

**6 NON-STRUCTURAL HEADER, WINDOW RAIL, OR GIRT TO POST CONN. DETAIL**  
Not To Scale

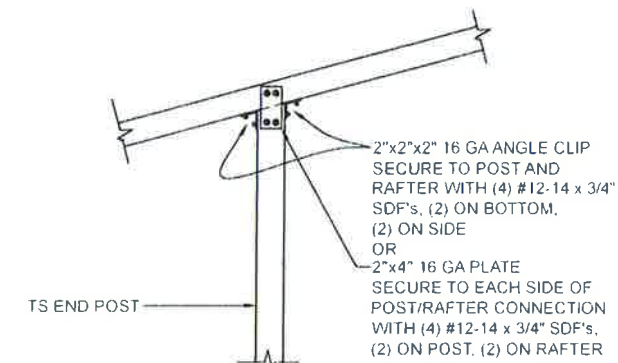

**7 END POST/RAFTER CONN. DETAIL**  
Not To Scale

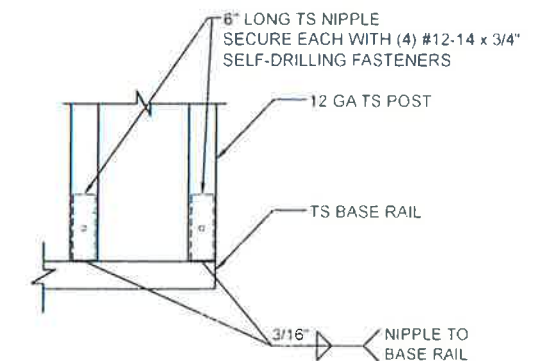

**8 RAFTER POST/BASE RAIL CONNECTION DETAIL**  
Not To Scale

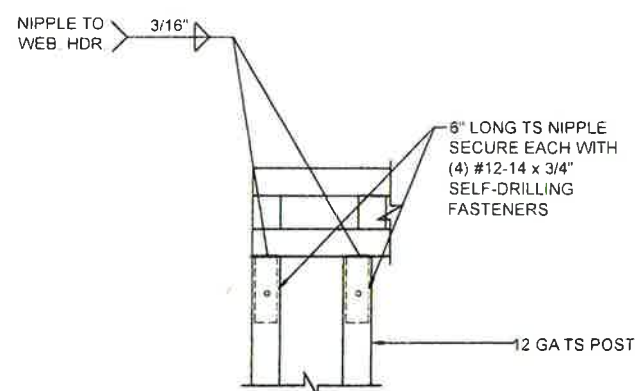

**9 RAFTER POST/WEB HEADER DETAIL**  
Not To Scale

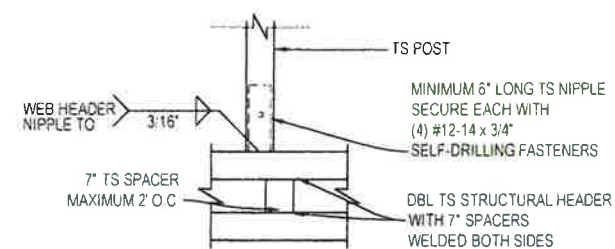

**10 WEB HEADER TOP/RAFTER POST CONNECTION DETAIL**  
Not To Scale

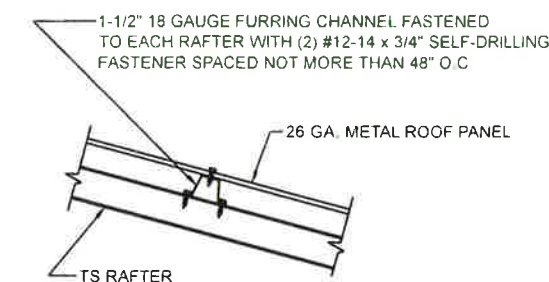

**ROOF PANEL ATTACHMENT**  
Not To Scale

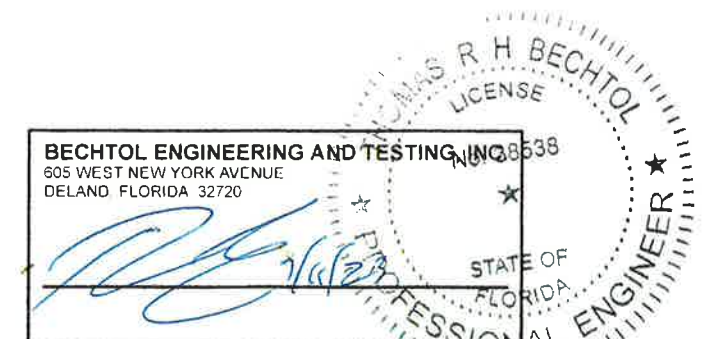

**BECHTOL ENGINEERING AND TESTING, INC.**  
605 WEST NEW YORK AVENUE  
DELAND FLORIDA 32720

**PROPOSED UTILITY STRUCTURE**  
**3104 INDIAN DRIVE**  
**BELLE ISLE, ORANGE COUNTY, FLORIDA**

**BECHTOL ENGINEERING AND TESTING, inc.**  
CONSULTING GEOTECHNICAL, ENVIRONMENTAL, AND MATERIALS TESTING ENGINEERS  
City/State of Florida License No. 30095400

DATE	05/23/2023
SCALE	NTS
PROJECT	CS/LP
PROJECT NO.	G23001
APPROVED	ZS/LP
SHEET 3 OF 3	