

RECORDING REQUESTED BY: CITY CLERK WHEN RECORDED RETURN TO: City Clerk City of Beaumont 550 E. 6th Street Beaumont, CA 92223	 SPACE ABOVE THIS LINE FOR RECORDER'S USE
--	--

CITY OF BEAUMONT
SUBDIVISION IMPROVEMENT AGREEMENT
TRACT NO. 37696

DATE OF AGREEMENT: <u>April 18, 2022</u>		
NAME OF SUBDIVIDER: <u>Richmond American Homes of Maryland, Inc.</u> , a <u>Maryland Corporation</u> (hereinafter referred to as "Subdivider").		
NAME/NUMBER OF DEVELOPMENT: <u>Seasons at The Fairways</u> subdivision consisting of <u>62</u> residential lots, _____, originally approved on _____, and Tentative Tract <u>37696</u> ("Tract" or "Tentative Tract Map"), originally approved on <u>February 4, 2020</u> .		
FINAL TRACT MAP _____ APPROVED ON _____ RECORDED ON _____ AS INSTRUMENT NUMBER: _____ ("Final Tract Map").		
PROPERTY SUBJECT TO AGREEMENT: The real property which is the subject of this Agreement is located in the City of Beaumont, County of Riverside and is described in Exhibit "A" attached hereto and incorporated herein (hereinafter the "Property").		
EST. TOTAL COST OF PUBLIC IMPROVEMENTS: \$ <u>49,392.50</u> (see Exhibit "B")	EST. TOTAL COST OF PRIVATE IMPROVEMENTS: \$ _____ (see Exhibit "B")	EST. TOTAL COST OF MONUMENTATION: \$ _____ (see Exhibit "B")
BOND NUMBERS: <u>107590438</u>		
LETTER OF CREDIT NUMBERS: _____		

FINANCIAL INSTITUTION: Travelers Casualty and Surety Company of America

THIS SUBDIVISION IMPROVEMENT AGREEMENT ("Agreement") is made and entered into by and between the City of Beaumont, a California municipal corporation (hereinafter referred to as "City"), and Richmond America Homes of Maryland, Inc, a Maryland Corporation, (hereinafter referred to as "Subdivider"). City and Subdivider are sometimes referred to hereinafter individually as a "Party", and collectively as the "Parties".

RECITALS

A. Subdivider is the owner of certain real property located in the City of Beaumont legally described on Exhibit "A" attached hereto and incorporated and made part of this Agreement by this reference (the "Property").

B. The conditions of approval of the above referenced Tentative Tract Map and any related entitlements, which are hereby incorporated herein by this reference, require that prior to the issuance of building permits, the Subdivider and the City shall enter into a subdivision improvement agreement, secured with sufficient security, as a guarantee of the construction and completion of all public and private improvements and land development work required by said conditions of approval and by the City subdivision laws and codes.

D. In consideration of the approval of a final map by the City Council, Subdivider desires to enter into this Agreement, whereby Subdivider promises to install and complete, at Subdivider's own expense, all the public improvement work required by City in connection with the proposed subdivisoion. Subdivider has secured this Agreement by improvement security required by the Subdivision Laws.

E. Improvement Plans (the "Plans") for the construction, installation, and completion of the public and private improvements are being or have been prepared by Subdivider and will be subject to approval by the Director of Engineering/Public Works ("City Engineer"). The City has adopted standards (hereinafter "Standards") for the construction and installation of improvements within the City, and the Plans will be prepared in conformance with the Standards in effect on the date of the approval of the Application. The Plans will be on file in the Office of the City Engineer and are incorporated into this Agreement by this reference as if set forth fully herein. All references in this Agreement to the Plans shall be deemed to include reference to any specifications for all of the improvements as approved by the City Engineer.

F. An estimate of the cost for construction of the public and private improvements and performing the land development work according to the Plans has been made and approved by the City Engineer. The estimated cost of these improvements is set forth on Page One (1) of this Agreement, and the basis for the estimate is attached hereto as Exhibit "B" and incorporated and

made part of this Agreement by this reference. The amounts of the Improvement Securities required to be posted with this Agreement are also based upon the estimate in Exhibit "B".

G. For the purposes of this Agreement, the term "Public Improvements" means all those improvements within the Tract intended for transfer or conveyance to the City or other public agency. The estimated cost of their construction is included in the above estimate included herein as Exhibit "B".

NOW, THEREFORE, in consideration of the issuance of the Final Tract map, Subdivider and City hereby agree as follows:

1. Subdivider's Obligation to Construct Improvements.

(a) In constructing and installing the improvements, Subdivider shall comply with all of the requirements and conditions of approval of in the Tentative Tract Map, related entitlements as well as the provisions of the Municipal Code and Subdivision Laws.

(b) Subdivider shall complete, at its own expense, all the public and private improvements and related work on the Development, as required by the conditions of approval of the Tentative Map and related entitlements in conformance with the approved Plans and City Standards, including without limitation, those improvements set forth in Exhibit "B" (hereinafter collectively the "Improvements") within twenty-four (24) months of the date of this Agreement, unless a time extension is granted by the City as authorized by Section 20 of this Agreement.

(c) Notwithstanding the time limits specified in Section 1(b) above, no single family dwelling unit or group of units shall be given final inspection and clearance for occupancy by City unless the private and public streets providing access to and fronting such units are completed, the final lifts of pavement on the streets are in place, and all wet and dry utility services (e.g. sewer, water, electrical power, telephone, gas, etc.) to such units are in place and are operational.

(d) Subdivider shall furnish the necessary materials for completion of the Improvements in conformity with the Plans and City Standards.

(e) Subdivider shall acquire and dedicate, or pay the cost of acquisition by the City, of all right-of-way, easements and other interests in real property required for construction or installation of the Improvements, free and clear of all liens and encumbrances. Subdivider's obligations relating to acquisition by City of off-site rights-of-way, easements and other interests in real property shall be subject to a separate agreement between Subdivider and City. Subdivider shall also be responsible for obtaining any public or private drainage easements or authorizations therefor to accommodate the Development.

(f) Subdivider shall furnish and install all monuments, stakes and property corners on the lots and streets in the Property as specified on the final recorded tract maps for the Development in accordance with the provisions of the Subdivision Laws, and shall submit centerline tie sheets to City, within thirty (30) days after completion of the Improvements, or as

specified in any separate monument agreement with the City, but in any event prior to their acceptance by the City.

2. Improvement Securities.

(a) Subdivider agrees to secure this Agreement with good and sufficient improvement securities in a form approved by the City Attorney (referred collectively hereinafter as "Improvement Securities" and individually as "Improvement Security") to guarantee the construction and completion of all the improvements in the Development. All such improvement securities shall be posted with the City prior to the City's final building inspection and issuance of a Certificate of Occupancy for any single family dwelling constructed by Subdivider, its agents, assigns or contractors, on any lot within the Development, as described in Exhibit "A". Said securities are estimated at this time in Exhibit "B" to be in the following amounts, and shall be for the purposes described as follows:

(i) \$49,392.50 and 00/100 DOLLARS (\$XXX,XXX.XX) to ensure faithful performance of the construction and installation of the public and private Improvements required by this Agreement ("Performance Security"), which amount is 100% of the estimated cost of the Improvements as set forth in Exhibit "B"; and

(ii) \$49,392.50 and 00/100 DOLLARS (\$XXX,XXX.XX) to secure payment to any contractor, subcontractor, persons renting equipment or furnishing labor materials for the Improvements required to be constructed or installed pursuant to this Agreement ("Labor & Materials Security"), which amount is one-hundred percent (100%) of the estimated cost of the Improvements; and

(iii) N/A and 00/100 DOLLARS (\$ XX,XXX.XX) in the form of a Warranty Bond or cash deposit with the City to guarantee or warranty the Improvement work done pursuant to this Agreement for a period of one (1) year following acceptance/certification thereof by City, against any defective work or labor done or defective materials furnished ("Warranty Security"). The Warranty Security is 10% of the estimated cost of the Performance Security amount described above, and such Warranty Security must be provided by Subdivider to City prior to the City's release of any bonds or Improvement Securities filed with this Agreement.

(iv) N/A and 00/100 Dollars (\$X,XXX.XX) in the form of a cash deposit, which is 100% of the estimated cost of setting all final subdivision monuments, boundary corners, front and rear lot corners and centerline ties not previously set or submitted on the lots and streets within the Property as described in Exhibit "A", and for the preparation and recordation of any related Certificate of Correction, as required by Section 66469 of the State Subdivision Map Act.

(b) The Improvement Securities required by this Agreement shall be kept on file with the City Clerk. If surety bonds are used, they must be issued by a surety company currently admitted to transact surety insurance business in California by the California Department of

Insurance, with a Best's Insurance Guide rating of no less than A-. The terms of any documents evidencing such Improvement Securities as set forth in this Section 2 or referenced on Page One (1) of this Agreement, are incorporated into this Agreement by this reference as if set forth fully herein. If any Improvement Security is replaced by another type or kind of approved Improvement Security, subject to the approval of the form thereof by the City Attorney, the replacement shall be filed with City Clerk and, upon filing, shall be deemed to have been made a part of and incorporated into this Agreement. Upon filing of a satisfactory replacement Improvement Security with the City Clerk, the former Improvement Security shall be released.

(c) Subdivider agrees to keep its Improvement Securities in full force and effect until they are reduced or released by City. If any Improvement Security provided by Subdivider is cancelled or terminated for any reason by the action of a surety, financial institution or other party, it shall be the responsibility of the Subdivider to immediately, upon written notice from City, provide a substitute Improvement Security which conforms to all the requirements of this Section 2 in the same amount or amounts.

(d) Any additions, changes, alterations, or modifications of this Agreement or to the Plans, Specifications and Improvements referred to herein, including any extension of time within which the work hereunder may be completed, shall not release or exonerate any surety or sureties on the Improvement Security given in connection with this Agreement.

3. Alterations to Improvement Plans; Modification of City Standards.

(a) Any changes, alterations or additions to the Plans or to the Improvements, not exceeding 10% of the original estimated cost of the Improvements, which are mutually agreed upon by City and Subdivider, shall not require Subdivider to increase any Improvement Securities provided under this Agreement. In the event such changes, alterations, or additions exceed 10% of the original estimated cost of the Improvements, Subdivider shall provide additional Performance Security as required by Section 2 of this Agreement for 100% of the total estimated cost of the Improvements as changed, altered, or amended, minus any completed partial releases allowed by Section 7 of this Agreement. Subdivider shall also provide additional Labor & Materials Security as required by Section 2 of this Agreement for 50 % of the total estimated cost of the Improvements as changed, altered, or amended.

(b) Subdivider shall construct all Improvements in a good and workman like manner and in accordance with the City Standards in effect as of the date of the Approval Action specified on Page One (1) hereof. The City reserves the right to modify the Standards applicable to the Subdivision and this Agreement, when necessary to protect the public safety or welfare or to comply with applicable State or Federal law or City zoning ordinances. If Subdivider requests and is granted an extension of time for completion of the Improvements, the City may apply the Standards in effect at the time the extension is granted.

4. Modification of Drainage Plan. Subdivider agrees that if during the course of construction and installation of Improvements it shall be determined by the City Engineer that

revision of the drainage plan is necessary in the public interest, it will undertake such design and construction changes as may be reasonable and as are indicated by the City Engineer and approved by City. Said changes, if any, shall be confined to the Property.

5. Reserved.

6. Inspections; Final Acceptance and Certification of Improvements.

(a) Subdivider shall at all times maintain proper facilities and safe access for inspection of the Improvements by City inspectors and to the shops wherein any work is in preparation.

(b) Upon completion of the Improvements covered in this Agreement, the Subdivider shall request a final inspection by the City Engineer or his/her authorized representative. Following receipt of such request, the City Engineer shall inspect the Improvements, make certain determinations and take certain actions as follows:

(i) If the City Engineer, or his/her authorized representative, determines that the Public Improvements requiring acceptance by another public agency have been completed in accordance with this Agreement, then the City Engineer shall request said agency to make a final inspection of such improvements and certify to the City that such improvements have been completed and installed to the satisfaction of said agency. Upon receipt of such certification, the City Engineer may release or reduce the securities held for such improvements. Any certification and/or acceptance of the Public Improvements shall not constitute a waiver of any defects by City.

(ii) For Improvements not requiring dedication to or acceptance by the a public agency (the "Private Improvements"), the City Engineer or his/her authorized representative shall inspect such improvements, and/or shall have the discretion to accept a certification from Subdivider's registered civil engineer stating that the Private Improvements have been completed in accordance with the approved Plans, City Standards and the Tentative Map. If the City Engineer, or his/her authorized representative, makes a finding, based on his/her own inspection (and/or any certification submitted by Subdivider's registered civil engineer) that the Private Improvements have been installed and constructed in accordance with the approved Plans, City Standards and the Tentative Map, the City Engineer shall recommend certification of the completion of the Private Improvements by placing an item on the next most convenient City Council agenda requesting certification and authorization to release the Improvement Securities. Said determination by the City Engineer and agendization of the certification and release shall not be unreasonably withheld or delayed.

(c) Subdivider shall bear all costs of inspection and certification of the Improvements.

7. Release of Improvement Securities.

(a) The Performance Security shall be fully released only upon the final completion and certification of all Private Improvements and Public Improvements. Partial releases may be

permitted subject to the provisions of Subsections (a)(i) and (a)(ii) hereof. Upon final completion of the Public and Private Improvements under this Agreement, and after City Council acceptance/certification, the City shall file a Notice of Completion in accordance with the California Civil Code.

(i) The City Engineer may release a portion of the Performance Security, as work on the Improvements progresses, upon written application thereof by the Subdivider; provided, however, that no such release shall be considered by City for an amount less the cost estimate of the remaining work does not exceed twenty percent (20%) or less of the estimate of the total amount of work to be done as shown in Exhibit "B". Upon approval of a partial release or the reduction of Performance Security, the City shall not reduce such Performance Security to an amount less than two-hundred- percent (200%) of the value of the work remaining to be done. City and Subdivider agree that not more than two requests for reduction or partial release of Performance Security shall be considered between the start of construction and the completion and acceptance/certification of the Improvements by the City.

(ii) In no event shall the City Engineer authorize a release or reduction of the Performance Security which would reduce such security to an amount below that required to guarantee the completion of the Improvements and any other obligations imposed upon Subdivider by this Agreement.

(iii) No partial reduction or release of the Performance Security shall constitute or be construed as the City's acceptance or certification of any Improvements or related work. Such partial reductions or releases (if any) will merely reflect that a certain portion of the required work has been done.

(b) The Labor & Materials Security shall, ninety (90) days after the City's recordation of the Notice of Completion described in Subsection 7(a), be reduced to an amount equal to the total claimed by all claimants for whom liens have been filed and of which notice has been given to City, plus an amount reasonably determined by the City Engineer to be required to assure the performance of any other obligations secured by the Labor & Materials Security and to cover related legal costs. The balance shall be released upon the settlement of all claims and obligations for which the Labor & Materials Security was given. If no claims or liens have been filed and no notice has been given to City within said ninety (90) day period, then the Labor & Materials Security shall be released in full.

(c) The Warranty Security shall not be released until after the expiration of the one-year (1-year) warranty period and until any claims filed during the warranty period have been settled. As provided in Section 11, below, the warranty period shall not commence until final acceptance/certification of the Improvements and related work by the City Council.

(d) The Monumentation Security may be released in full by the City Engineer in accordance with the terms of the separate monument agreement with the City, or if there is none, upon submittal of the following:

(i) a written certification from the professional engineer or surveyor responsible for setting the monuments stating that all the final monuments for the Subdivision have been set in accordance with the Professional Land Surveyors Act and the Subdivision Map Act, and that the professional engineer or surveyor has been paid in full by Subdivider for such services; and

(ii) centerline tie sheets prepared in a manner acceptable to the City Engineer showing the locations of centerline monuments in existing public or private streets; and

(iii) any Record of Survey required by this Agreement has been filed with the County of Riverside and recorded.

(e) The City may retain from any Improvement Securities released an amount sufficient to cover costs and reasonable expenses and fees, including reasonable attorneys' fees.

8. Injury to Public Improvements, Public Property or Public Utilities Facilities.

Subdivider shall replace or repair, or cause the repair or replacement of any and all public or private improvements, public utilities facilities and survey or subdivision monuments which are destroyed or damaged as a result of any work under this Agreement. Subdivider shall bear the entire cost of replacement or repairs of any and all public or private improvements or utility property damaged or destroyed by reason of any work done under this Agreement, whether such property is owned by the United States or any agency thereof, or the State of California, or any agency or political subdivision thereof, or by the City or any public or private utility corporation or by any combination of such owners. Any repair or replacement shall be made to the reasonable satisfaction, and subject to the approval of the City Engineer and the owner of any such public or private improvement.

9. Permits. Subdivider shall, at Subdivider's expense, obtain all necessary permits and licenses for the construction and installation of the Improvements, give all necessary notices and pay all fees and taxes required by law.

10. Notice of Breach/Default of Subdivider.

(a) Default of Subdivider shall include, but not be limited to: (1) Subdivider's failure to timely complete construction of the Improvements; (2) Subdivider's unwarranted failure to timely cure any defect in the Improvements; (3) Subdivider's failure to perform substantial construction work for a period of twenty (20) consecutive calendar days after commencement of the work; (4) Subdivider's insolvency, appointment of a receiver, or the filing of any petition in bankruptcy either voluntary or involuntary which Subdivider fails to discharge within thirty (30) days; (5) the commencement of a foreclosure action against the Property or a portion thereof, or any conveyance in lieu or in avoidance of foreclosure; (6) Subdivider's failure to keep the Improvement

Securities in full force and effect; (7) Subdivider's failure to notify the City of any sale, transfer or other disposition of the Property to a purported new Subdivider; (8) Subdivider's failure to maintain insurance; or (9) the failure of Subdivider or Subdivider's contractors, subcontractors, agents or employees to comply with any other terms and provisions of this Agreement.

(b) In the event of any such default, the City Engineer or the City Council may serve written notice to Subdivider specifying in reasonable detail the nature of the default. Subdivider shall have thirty (30) days from receipt of said notice to cure the default; provided that, if the default is not reasonably susceptible to being cured within said thirty (30) days, Subdivider shall have a reasonable period of time to cure the default so long as Subdivider commences to cure the default within said thirty (30) days and diligently prosecutes the cure to completion.

(c) If following service of such written notice of default, Subdivider fails to cure or commence curing the default to the satisfaction of City within the cure period specified in Subsection 10(b), above, the City Engineer or the City Council may serve notice of Subdivider's default upon Subdivider and where applicable Subdivider's surety, or the holder(s) of any other Improvement Securities, in accordance with the notice provisions set forth in Section 22 of this Agreement.

(d) In the event of service of the notice of default specified in Subsection 10(c), above, Subdivider's surety shall have the duty to take over and complete the Improvements and related work required under this Agreement; provided; however, that if the surety, within twenty (20) days after the serving upon it of such notice of default, does not give the City written notice of its intention to take over the construction of said Improvements or does not, within ten (10) days after giving City notice of such election, commence to complete the Improvements, City may take over the work and prosecute the Improvements to completion, by contract or by any other method City may deem advisable, for the account and at the expense of Subdivider, and Subdivider's surety shall be liable to City for any costs or damages occasioned City thereby; and, in such event, City, without liability for so doing, may take possession of, and utilize in completing the Improvements, such materials, appliances, plant and other property belonging to Subdivider as may be on the site of the work and necessary for the completion of same.

(e) The City reserves to itself all remedies available to it at law or in equity for Subdivider's default under this Agreement. The City shall have the right, subject to this Section, to draw upon or utilize the appropriate Improvement Securities to mitigate City's damages in event of default by Subdivider. The right of City to draw upon or utilize the Improvement Securities is additional to and not in lieu of any other remedy available to City. It is specifically recognized that the estimated costs and amounts of Improvement Securities may not reflect the actual cost of construction or installation of the Improvements, and therefore, City's damages for Subdivider's default shall be measured by the actual cost of completing the required Improvements. The sums provided by the Improvement Securities may be used by City for the completion of the Improvements in accordance with the Plans.

(f) Failure of Subdivider to comply with the terms of this Agreement, including but not limited to, construction of all the Improvements as set forth herein and as required by the Tentative Map, shall constitute Subdivider's consent to: (1) the filing by City of a notice of violation against all of the lots in the Subdivision; (2) withholding of Building permits, utility connections and/or Certificates of Occupancy. The remedies provided by this Subsection (f) are in addition to and not in lieu of any other remedies available to City at law or in equity. Subdivider agrees that the choice of remedy or remedies for Subdivider's default or breach shall be in the sole discretion of City.

(g) In the event that Subdivider fails to perform any obligation hereunder, Subdivider agrees to pay all costs and expenses incurred by City in securing performances of such obligations, including costs of suit and reasonable attorney's fees.

(h) The failure of City to take an enforcement action with respect to a default, or to declare a default or breach, shall not be construed as a waiver of that default or breach, or of any subsequent default or breach of Subdivider. Any failure by the City to enforce any provision of this Agreement shall not be construed as a waiver of the right to compel enforcement of such provision(s) and further shall not act to release any surety from its obligations under this Agreement.

11. Warranty.

(a) For a period of one (1) year after final acceptance/certification by the City Council of the Improvements, Subdivider shall guarantee or warranty all the Improvements against any defective work or labor done or defective materials furnished. If within the warranty period any work relating to the Improvements or any part of thereof furnished, installed, constructed or caused to be done, furnished, installed or constructed by Subdivider fails to fulfill any of the requirements of this Agreement or the Plans, Subdivider shall without delay and without any cost to City, commence to repair or replace or reconstruct any defective or otherwise unsatisfactory part or parts of the work or structure within thirty (30) days of receiving written notice from City of the defect and diligently prosecute the repair or replacement work to completion.

(b) Should Subdivider fail to act promptly or in accordance with the repair/replacement requirements set forth herein, Subdivider hereby authorizes City, at City's option, to perform the repair/replacement work twenty (20) days after mailing written notice to Subdivider and to Subdivider's surety, and Subdivider agrees to pay City for the cost of such work.

(c) Should the City determine that an emergency or a threat to the public safety and welfare exists from the condition of the Improvements which require repairs, replacements or remedial measures to be made before Subdivider can be notified, City may, in its sole discretion, make the necessary repairs or replacements or perform the necessary work and Subdivider shall pay to City the cost of such repairs.

12. Subdivider Not Agent of City. Neither Subdivider nor any of Subdivider's agents, officers, employees, or contractors are or shall be considered to be agents of City in connection with the performance of Subdivider's obligations under this Agreement.

13. Injury to Improvement Work; Risk of Loss. Until such time as the Public Improvements are accepted by City, Subdivider shall be responsible for and bear the risk of loss to any of the Public Improvements constructed or installed and shall be responsible for the care, maintenance of and any damage to such Public Improvements. Neither City, nor any of its agents, officers or employees shall be liable or responsible for any accident, loss or damage, regardless of cause, happening or occurring to the Public Improvements specified in this Agreement prior to the completion and acceptance of the Public Improvements by City. All such risks shall be the responsibility of and are hereby assumed by Subdivider. Subdivider is responsible for and shall bear the risk of loss for all Private Improvements at all times.

14. Other Agreements. Nothing contained in this Agreement shall preclude City from expending monies pursuant to agreements concurrently or previously executed between the Parties, or from entering into agreements with other Subdividers for the apportionment of costs of water and sewer mains, or other improvements, pursuant to the provisions of City ordinances providing therefor, nor shall anything in this Agreement commit to any such apportionment.

15. Subdivider's Obligation to Warn Public During Construction. Until final acceptance/certification of the Public Improvements pursuant to Section 6(b)(i), and final certification of construction of the Private Improvements pursuant to Section 6(b)(ii), Subdivider shall give good and adequate warning to the public of each and every dangerous condition existent in said Improvements, and will take all reasonable actions to protect the public from such dangerous conditions in, on or around the work site.

16. Vesting of Ownership. Upon acceptance of the Public Improvements and related work on behalf of the City, and after recordation of the Notice of Completion, ownership of the Public Improvements constructed within the Private streets in the Development shall vest in the name of the City, or applicable government agency or utility company, and any improvement constructed on any public street pursuant to this Agreement shall vest in City.

17. Indemnity/Hold Harmless.

(a) Neither the City, nor any official, officer, employee, contractor or agent thereof, shall be liable for any injury to persons or property occasioned by reason of the acts or omissions of Subdivider, its agents, subcontractors or employees in the performance of this Agreement. Subdivider hereby agrees to, and shall defend and hold harmless City, its elective and appointive boards, commissions and officers, and its agents, contractors and employees from and against any and all claims, demands, causes of action, damages, costs, expenses, actual attorneys' fees, consultant's fees, expert's fees, losses or liability, in law or in equity, of every kind and nature whatsoever arising out of or in connection with Subdivider's operations, or any subcontractor's operations, to be performed under this Agreement for Subdivider's or subcontractor's tort

negligence including active or passive, or strict negligence, including but not limited to personal injury including, but not limited to bodily injury, emotional injury, sickness or disease, or death to persons and/or damage to property of anyone, including loss of use thereof, caused or alleged to be caused by any act or omission of Subdivider or any subcontractor, or anyone directly or indirectly employed by any of them or anyone for the full period of time allowed by law, with the exception of the sole negligence or willful misconduct of City.

(b) Subdivider's indemnity, defense and hold harmless obligations under this Section 17 are not conditioned or dependent upon whether City, or its elective and appointive boards, commissions and officers, or its agents, contractors and employees, prepared, supplied or reviewed any Plans or related specifications in connection with the Improvements, or whether City or Subdivider has insurance or other indemnification covering any of these matters.

(c) Subdivider's obligation to indemnify, hold harmless and defend City shall extend to injuries to persons and damages to or alleged taking of property resulting from the design or construction of the Improvements. City's acceptance and/or certification of the Improvements shall not constitute an assumption by City of any responsibility or liability for any damage or alleged taking of property referenced herein. City shall not be responsible or liable for the design or construction of the Improvements constructed or installed pursuant to the Plans, unless the particular Improvement design was required by City over the written objection of Subdivider, which objection stated that the Improvement design was potentially dangerous or defective and set forth a safe and feasible alternative design. After City's acceptance/certification of the Improvements, Subdivider shall remain obligated to correct or eliminate all dangerous conditions caused by defects in design or construction; provided, however, that the Subdivider shall not be responsible for routine maintenance. Subdivider acknowledges and agrees that Subdivider shall be responsible and liable for the design and construction of the Improvements and other work done pursuant to this Agreement, and except as may be provided above, City shall not be liable for any acts or omissions in approving, reviewing, checking, correcting or modifying any Plans, or in inspecting, reviewing or approving any work or construction of Improvements. Subdivider's Improvement Securities shall not be required to secure Subdivider's obligations under this Section 17.

18. Sale or Disposition of Subdivision; Assignment.

(a) Subdivider acknowledges and agrees that sale, transfer or other disposition of the Property prior to completion of the Improvements required hereunder will not relieve Subdivider from the obligations set forth in this Agreement, and Subdivider shall be required to notify City sixty (60) days in advance of any sale or transfer of ownership of the Property or any proposed assignment of this Agreement. If Subdivider sells or otherwise transfers the Property to any other person or entity prior to final completion of the Improvements, or wishes to assign this Agreement, Subdivider may request a novation of this Agreement and a substitution of Improvement Securities by the new owner or proposed assignee (hereinafter collectively for purposes of this Section, "Successor"). Subdivider shall be required to provide any documentation reasonably required by City to determine the appropriateness of any proposed Successor.

(b) Any proposed Successor must demonstrate to the City its ability to perform and complete the obligations of Subdivider under this Agreement, as determined by objective standards of financial capability, creditworthiness and experience required for such performance, and the City shall have the right to compel the Successor to disclose all documents, information and other material which, in City's sole reasonable discretion, may establish or tend to establish that the proposed Successor meets the standards specified herein. Following approval by City and full execution of a novation (or other such release or assignment and assumption agreement(s) entered into by Subdivider, Successor and City), posting of satisfactory Improvement Securities and submission of required insurance by Successor, City shall release or reduce the securities posted by Subdivider in accordance with the provisions of such novation and release Subdivider of its obligations under this Agreement. Nothing in the novation (or other such release or assignment and assumption agreement entered into by Subdivider, Successor and City) shall relieve Subdivider of its obligations under any other Section of this Agreement for work or Improvements performed by Subdivider prior to the novation.

19. Time of the Essence. Time is of the essence in this Agreement.

20. Time for Completion of Improvements; Extensions.

(a) Subdivider shall commence and diligently prosecute to completion construction of all the Improvements required by this Agreement. The time for completion of the Improvements as specified in Subsection 1(b) of this Agreement may be extended as permitted by City ordinance. The City Manager may grant an extension of time for such period as may be in the public interest upon the showing of the Subdivider of good cause. Any such extension granted shall be subject to the limitations and conditions set forth in Subsections 20(b) and (c), below, and shall be made by a writing executed by the in a form as approved by the City Attorney.

(b) Any such extension may be granted without notice to Subdivider's surety and shall not affect the validity of this Agreement or release the surety or sureties on any Improvement Securities given for this Agreement. However, City reserves the right to require as part of any extension amendment a written assurance from the surety acceptable to the City Attorney that the Improvement Securities required by Section 2 of this Agreement shall remain enforceable throughout the term of any extension.

(c) The City Manager shall be the sole and final judge as to whether or not good cause has been shown to entitle Subdivider to an extension. In addition, the time for completion of the Improvements shall be extended for any delay resulting from an act of City, or from an act of God, which Subdivider could not have reasonably foreseen, or by storm or inclement weather which prevents the conducting of work, or by strikes, boycotts, similar actions by employees or labor organizations, which prevent the conducting of work, and which were not caused by or contributed to by Subdivider, provided that Subdivider provides City with written notice of the delaying event within fifteen (15) days of the commencement of the delay. In the event of such delaying event, Subdivider shall use all reasonable efforts to remedy same and resume completion of the Improvements as promptly as practicable.

(d) As a condition of granting an extension of time to complete the Improvements required by this Agreement, the City Manager may require Subdivider to furnish new or additional Improvement Securities guaranteeing performance of this Agreement as extended in an increased amount as necessary to compensate for any increase in construction costs as determined by the City Engineer.

21. Notice. All notices required by or provided for under this Agreement shall be in writing and delivered in person or sent by certified or registered mail, postage prepaid and addressed as provided in this Section. Notice shall be effective on the date it is delivered in person, or, if mailed, on the date of deposit in the United States Mail. Notices shall be addressed as follows unless a written change of address is filed with City:

Notice to City:	City of Beaumont 550 E. 6th Street Beaumont, CA 92223	Attn:
City Manager		

With a Copy to:	John Pinkney, Esq. SBEMP 1800 East Tahquitz Canyon Way Palm Springs, CA 92262
-----------------	--

Notice to Subdivider:

22. Severability. The provisions of this Agreement are severable. If any portion of this Agreement is held invalid by a court of competent jurisdiction, the remainder of the Agreement shall remain in full force and effect unless amended or modified in writing by the mutual consent of the Parties.

23. Captions. The captions of this Agreement are for convenience and reference only and shall not define, explain, modify, limit, exemplify, or aid in the interpretation, construction or meaning of any provisions of this Agreement.

24. Insurance.

(a) Subdivider shall, at all times during the construction of the Improvements, obtain, carry, maintain, and keep in full force and effect, at its sole cost and expense, policies of insurance of the types and in at least the minimum amounts described below:

(i) Commercial General Liability policy with a minimum combined single limit of One Million Dollars (\$1,000,000) for each occurrence and Two Million Dollars (\$2,000,000) in the aggregate for bodily injury, death, personal injury and property damage arising out of or in connection with the activities of the Subdivider and its contractors and subcontractors in performance of the work under this Agreement. Coverage shall be at least as broad as Insurance Services Office Commercial General Liability coverage

(Occurrence Form CG 0001) and shall, in addition to the other coverages specified in this subsection, include coverage for independent contractors, ongoing operations, products and completed operations, contractual liability and personal and advertising injury.

(ii) Commercial Vehicle/Automotive Liability policy covering personal injury and property damage, with minimum limits of One Million Dollars (\$1,000,000) per occurrence, combined single limit, covering any vehicle utilized by Subdivider, its officers, agents, employees, subcontractors or independent contractors in performing the work required by this Agreement.

(iii) Workers' Compensation and Employer's Liability policy for all Subdivider's employees, with Workers' Compensation limits as required by State law and Employer's Liability coverage of \$1,000,000 per accident for bodily injury or disease. In case any work is sublet, Subdivider shall require any contractor or subcontractor similarly to provide Workers' Compensation and Employer's Liability Insurance for all contractor's or subcontractor's employees, unless such employees are covered by the protection afforded by Subdivider.

(1) In case any class of employees engaged in work under this Agreement at the work site(s) is not protected under any Workers' Compensation law, Subdivider shall provide and shall cause each contractor or subcontractor to provide, adequate insurance for the protection of employees not otherwise protected.

(2) Subdivider hereby indemnifies City for any damages or claims resulting from failure of either Subdivider or any contractor or subcontractor to take out or maintain such liability or Workers' Compensation insurance.

(b) Insurer Rating: Acceptability. Except as set forth otherwise herein, the policies required by this Section shall be issued by a California-admitted insurer with a rating of at least A-; VII in the latest edition of Best's Insurance Guide. A Commercial General Liability policy issued by an insurer that is on the California Department of Insurance's List of Approved Surplus Line Insurers ("LASLI") will be acceptable, if no coverage from an admitted insurer can be obtained by Subdivider, and further provided that such insurer maintains a Best's rating of at least "A-; X" and remains on the LASLI during the term hereof. Workers' Compensation coverage issued by the State Compensation Insurance Fund shall be acceptable if no other coverage can be obtained by Subdivider, and further provided such insurer remains admitted in California and is otherwise financially acceptable to City.

(c) Deductibles. Any deductibles or self-insured retentions must be declared in writing by Subdivider to City and subsequently approved by City prior to its execution of this Agreement and prior to commencement of any work hereunder. At City's option, Subdivider shall either reduce or eliminate the deductibles or self-insured retentions with respect to City, or Subdivider shall procure a bond guaranteeing payment of losses and expenses.

(d) Certificates and Endorsements Verification. Subdivider shall submit to the City original certificates of insurance and endorsements evidencing the coverages required by this Section. The certificates and endorsements for each insurance policy shall be signed by a person authorized by that insurer to bind coverage on its behalf. The City reserves the right to require complete, certified copies of all required insurance policies at any time and/or to require Subdivider to provide reports or status updates to evidence compliance of its contractors and subcontractors with the provisions of this Section.

(e) Required Endorsements.

(i) The Commercial General Liability and Commercial Vehicle/Automotive Liability policies are to contain or be endorsed to contain the following provisions:

(1) Additional Insureds. The City of Beaumont, its officials, officers, employees, agents and independent contractors shall be named as additional insureds with respect to liability arising out of automobiles owned, leased, hired or borrowed by or on behalf of the Subdivider; and with respect to liability arising out of work or operations performed by or on behalf of the Subdivider including materials, parts or equipment furnished in connection with such work or operations.

(2) Primary Insurance. For any claims related to this project, the Subdivider's insurance coverage shall be primary insurance as respects the City of Beaumont, its officials, officers, employees, agents and independent contractors. Any insurance or self-insurance maintained by the City of Beaumont, its officials, officers, employees, agents and independent contractors shall be excess of the Subdivider's insurance and shall not contribute with it. This endorsement is not applicable to the Commercial Vehicle/Automotive Liability Policy.

(3) Waiver of Subrogation. Endorsements waiving all rights of subrogation against the City of Beaumont, its officials, officers, employees, agents and independent contractors shall be provided.

(ii) The Workers' Compensation policy shall be endorsed to waive all rights of subrogation against the City of Beaumont, its officials, officers, employees, agents and independent contractors.

(f) Other Insurance Requirements. All policies required under this Agreement shall contain provisions stating that such policies cannot be canceled or reduced except on at least thirty (30) days prior written notice to Subdivider (ten (10) days' notice for cancellation due to non-payment). Subdivider further agrees to: (1) provide to City copies of any notices relating to cancellation or reduction of insurance within two (2) days of receipt; and (2) cause all certificates of insurance to include language indicating that the issuers or producers of such policies will endeavor to provide copies of any such notices directly to City.

(g) Commencement of Work. Subdivider shall not commence work under this Agreement until Subdivider has obtained all insurance required pursuant to this Section, and such insurance has been obtained by Subdivider and approved by City; nor shall Subdivider allow any contractor or subcontractor to commence work on the Improvements until all similar insurance required of the contractor or subcontractor has been obtained. Certificates, endorsements, and where applicable, full copies of policies shall be maintained on file with the City Clerk.

(h) Higher Limits. If Subdivider maintains higher limits than the minimums specified in this Section 25, the City requires and shall be entitled to coverage for the higher limits maintained by Subdivider. Any available insurance proceeds in excess of the specified minimum limits of insurance and coverage shall be available to the City.

25. Attorneys' Fees. In the event any action at law or in equity is brought to enforce the terms of this Agreement, the prevailing Party shall be entitled to litigation costs and reasonable attorneys' fees.

26. Incorporation of Recitals. The Recitals to this Agreement are hereby incorporated into in the terms of this Agreement.

27. Entire Agreement. This Agreement constitutes the entire agreement of the Parties and supersedes any prior written or oral agreements between them with respect to the subject matter hereof. All modifications, amendments, or waivers of the terms of this Agreement must be in writing and signed by the appropriate representatives of the Parties.

28. Governing Law; Venue. This Agreement shall be governed by and interpreted in accordance with the laws of the State of California. In the event that suit shall be brought by either Party to this contract, the Parties agree that venue shall be exclusively vested in the State courts of the County of Riverside, California or where appropriate, in the United States District Court, Southern District of California, Riverside, California.

29. Runs with the Land; Recordation.

(a) The Parties agree that the terms and provisions set forth in this Agreement shall be deemed provisions, terms and/or covenants running with the Property in accordance with applicable law, including without limitation, California Civil Code section 1468, and shall pass to and be binding upon the heirs, successors and assigns of the Parties to this Agreement, and on any successor owner of the Property.

(b) The provisions of Subsection 29(a) notwithstanding, Subdivider shall remain jointly and severally liable with its heirs, successors, assigns or successor owners of the Property for the responsibilities and liabilities imposed by this Agreement unless a novation or assignment agreement is executed in accordance with the provisions of Section 18 of this Agreement.

(c) Upon execution, this Agreement shall be recorded in the Official Records of Riverside County, and by such recordation, it is the intention of the Parties to give notice to and bind their successors, heirs and assigns hereto.

30. Authority of Executing Parties. Each person executing this Agreement on behalf of a Party represents and warrants that such person is duly and validly authorized to do so all behalf of the entity it purports to bind and that he/she is authorized to enter into contracts on behalf of Subdivider. The undersigned, on behalf of Subdivider, binds Subdivider, its partners, successors, executors, administrators, and assigns with respect to the terms and provisions of this Agreement.

IN WITNESS WHEREOF, this Agreement is executed by the Parties hereto on the date above first written.

Subdivider:

City:

CITY OF BEAUMONT
a Municipal Corporation

By: 

EDGALL GOMEZ
VP PROJECT MANAGEMENT

By: _____
City Manager

ATTEST:

City Clerk

APPROVED AS TO FORM:

John Pinkney, City Attorney

APPROVED AS TO CONTENT:

Jeff Hart, Dir. Of Engineering/Public

Works

Attachments: Exhibit A Legal description of Property
 Exhibit B Cost estimates

(Proper Notarization of Subdivider's Signature is required and shall be attached)

Bond No.: 107590438

PERFORMANCE BOND

WHEREAS, the City Council of the City of Beaumont, State of California, and Richmond American Homes of Maryland, Inc. (hereinafter designated as "Principal") have entered into an agreement whereby Principal agrees to install and complete certain designated public improvements, which agreement, dated April 18th, 2022, and identified as project Tract 37696 (Lots 1-62), is hereby referred to and made a part hereof; and

WHEREAS, Principal is required under the terms of the said agreement to furnish a bond for the faithful performance of said agreement.

NOW, THEREFORE, we, the Principal and Travelers Casualty and Surety Company of America, as Surety, are held and firmly bound unto the City of Beaumont (hereinafter called "City"), in the penal sum of Forty Nine Thousand Three Hundred Ninety Two and 50/100ths dollars (\$49,392.50) lawful money of the United States, for the payment of which sum well and truly to be made, we bind ourselves, our heirs, successors, executors and administrators, jointly and severally, firmly by these presents.

The condition of this obligation is such that if the Principal, his or its heirs, executors, administrators, successors or assigns, shall in all things stand to and abide by, and well and truly keep and perform the covenants, conditions and provisions in the said agreement and any alteration thereof made as therein provided, on his or their part to be kept and performed at the time and in the manner therein specified, and in all respects according to their true intent and meaning, and shall indemnify and save harmless the City, its officers, agents and employees as therein stipulated, then this obligation shall become null and void; otherwise it shall be and remain in full force and effect.

As part of the obligation secured hereby and in addition to the face amount specified therefor, there shall be included costs and reasonable expenses and fees, including reasonable attorney's fees, incurred by the City in successfully enforcing such obligation, all to be taxed as costs and included in any judgment therein rendered.

The Surety hereby stipulates and agrees that no change, extension of time, alteration or addition to the terms of the agreement or to the work to be performed thereunder or the specifications accompanying the same shall in any way affect its obligations on this bond, and it does hereby waive notice of any such change, extension of time, alteration or addition to the terms of the agreement or to the work or to the specifications.

IN WITNESS WHEREOF, this instrument has been duly executed by the Principal and Surety above named, on April 4, 2022.

PRINCIPAL:

Richmond American Homes of Maryland, Inc.

By 
EDGAIL GOMEZ
Title VP PROJECT MANAGEMENT

SURETY:

Travelers Casualty and Surety
Company of America

By 
Title James I. Moore, Attorney-in-Fact

BOND FOR SECURITY OF LABORERS AND MATERIALMEN

WHEREAS, the City Council of the City of Beaumont, State of California, and Richmond American Homes of Maryland, Inc. (hereafter designated as "the Principal") have entered into an agreement whereby the Principal agrees to install and complete certain designed public improvements, which agreement, dated _____, 20____, and identified as project Tract 37696 (Lots 1-62), is hereby referred to and made a part hereof; and

WHEREAS, under the terms of the said agreement, the Principal is required before entering upon the performance of the work, to file a good and sufficient payment bond with the City of Beaumont to secure the claims to which reference is made in Title 15 (commencing with Section 3082) of Part 4 of Division 3 of the Civil Code of the State of California.

NOW, THEREFORE, the Principal and the undersigned as corporate surety, are held firmly bound unto the City of Beaumont and all contractors, subcontractors, laborers, materialmen, and other persons employed in the performance of the said agreement and referred to in Title 15 (commencing with Section 3082) of Part 4 of Division 3 of the Civil Code in the sum of Forty Nine Thousand Three Hundred Ninety Two and 50/100ths dollars (\$49,392.50), for materials furnished or labor thereon of any kind, or for amounts due under the Unemployment Insurance Act with respect to this work or labor, that the Surety will pay the same in an amount not exceeding the amount hereinabove set forth, and also in case suit is brought upon this bond, will pay, in addition to the face amount thereof, costs and reasonable expenses and fees, including reasonable attorney's fees, incurred by the City in successfully enforcing this obligation, to be awarded and fixed by the court, and to be taxed as costs and to be included in the judgment therein rendered.

It is hereby expressly stipulated and agreed that this bond shall inure to the benefit of any and all persons, companies, and corporations entitled to file claims under Title 15 (commencing with Section 3082) of Part 4 of Division 3 of the Civil Code, so as to give a right of action to them or their assigns in any suit brought upon this bond.

Should the condition of this bond be fully performed, then this obligation shall become null and void, otherwise it shall be and remain in full force and effect.

The Surety hereby stipulates and agrees that no change, extension of time, alteration, or addition to the terms of the agreement or the specifications accompanying the same shall in any manner affect its obligations on this bond, and it does hereby waive notice of any such change, extension, alteration, or addition.

IN WITNESS WHEREOF, this instrument has been duly executed by the Principal and Surety above named, on April 4, 2022.

PRINCIPAL:

SURETY:

Richmond American Homes of Maryland, Inc.

Travelers Casualty and Surety
Company of America

By 
Title VP PROJECT MANAGEMENT

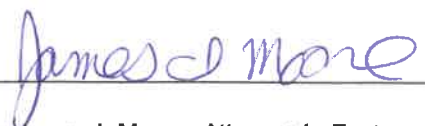
By 
Title James I. Moore, Attorney-in-Fact

TRAVELERS

**Travelers Casualty and Surety Company of America
Travelers Casualty and Surety Company
St. Paul Fire and Marine Insurance Company**

POWER OF ATTORNEY

KNOW ALL MEN BY THESE PRESENTS: That Travelers Casualty and Surety Company of America, Travelers Casualty and Surety Company, and St. Paul Fire and Marine Insurance Company are corporations duly organized under the laws of the State of Connecticut (herein collectively called the "Companies"), and that the Companies do hereby make, constitute and appoint **James I Moore** of **DOWNERS GROVE**, Illinois, their true and lawful Attorney(s)-in-Fact to sign, execute, seal and acknowledge any and all bonds, recognizances, conditional undertakings and other writings obligatory in the nature thereof on behalf of the Companies in their business of guaranteeing the fidelity of persons, guaranteeing the performance of contracts and executing or guaranteeing bonds and undertakings required or permitted in any actions or proceedings allowed by law.

IN WITNESS WHEREOF, the Companies have caused this instrument to be signed, and their corporate seals to be hereto affixed, this **21st** day of **April**, 2021.



State of Connecticut

City of Hartford ss.

By: *Robert L. Raney*
Robert L. Raney, Senior Vice President

On this the **21st** day of **April**, 2021, before me personally appeared **Robert L. Raney**, who acknowledged himself to be the Senior Vice President of each of the Companies, and that he, as such, being authorized so to do, executed the foregoing instrument for the purposes therein contained by signing on behalf of said Companies by himself as a duly authorized officer.

IN WITNESS WHEREOF, I hereunto set my hand and official seal.

My Commission expires the **30th** day of **June**, 2026



Anna P. Nowik
Anna P. Nowik, Notary Public

This Power of Attorney is granted under and by the authority of the following resolutions adopted by the Boards of Directors of each of the Companies, which resolutions are now in full force and effect, reading as follows:

RESOLVED, that the Chairman, the President, any Vice Chairman, any Executive Vice President, any Senior Vice President, any Vice President, any Second Vice President, the Treasurer, any Assistant Treasurer, the Corporate Secretary or any Assistant Secretary may appoint Attorneys-in-Fact and Agents to act for and on behalf of the Company and may give such appointee such authority as his or her certificate of authority may prescribe to sign with the Company's name and seal with the Company's seal bonds, recognizances, contracts of indemnity, and other writings obligatory in the nature of a bond, recognizance, or conditional undertaking, and any of said officers or the Board of Directors at any time may remove any such appointee and revoke the power given him or her; and it is

FURTHER RESOLVED, that the Chairman, the President, any Vice Chairman, any Executive Vice President, any Senior Vice President or any Vice President may delegate all or any part of the foregoing authority to one or more officers or employees of this Company, provided that each such delegation is in writing and a copy thereof is filed in the office of the Secretary; and it is

FURTHER RESOLVED, that any bond, recognizance, contract of indemnity, or writing obligatory in the nature of a bond, recognizance, or conditional undertaking shall be valid and binding upon the Company when (a) signed by the President, any Vice Chairman, any Executive Vice President, any Senior Vice President or any Vice President, any Second Vice President, the Treasurer, any Assistant Treasurer, the Corporate Secretary or any Assistant Secretary and duly attested and sealed with the Company's seal by a Secretary or Assistant Secretary; or (b) duly executed (under seal, if required) by one or more Attorneys-in-Fact and Agents pursuant to the power prescribed in his or her certificate or their certificates of authority or by one or more Company officers pursuant to a written delegation of authority; and it is

FURTHER RESOLVED, that the signature of each of the following officers: President, any Executive Vice President, any Senior Vice President, any Vice President, any Assistant Vice President, any Secretary, any Assistant Secretary, and the seal of the Company may be affixed by facsimile to any Power of Attorney or to any certificate relating thereto appointing Resident Vice Presidents, Resident Assistant Secretaries or Attorneys-in-Fact for purposes only of executing and attesting bonds and undertakings and other writings obligatory in the nature thereof, and any such Power of Attorney or certificate bearing such facsimile signature or facsimile seal shall be valid and binding upon the Company and any such power so executed and certified by such facsimile signature and facsimile seal shall be valid and binding on the Company in the future with respect to any bond or understanding to which it is attached.

I, **Kevin E. Hughes**, the undersigned, Assistant Secretary of each of the Companies, do hereby certify that the above and foregoing is a true and correct copy of the Power of Attorney executed by said Companies, which remains in full force and effect.

Dated this **4th** day of **April**, 2022



Kevin E. Hughes
Kevin E. Hughes, Assistant Secretary

**To verify the authenticity of this Power of Attorney, please call us at 1-800-421-3880.
Please refer to the above-named Attorney(s)-in-Fact and the details of the bond to which this Power of Attorney is attached.**

ACKNOWLEDGMENT

A notary public or other officer completing this certificate verifies only the identity of the individual who signed the document to which this certificate is attached, and not the truthfulness, accuracy, or validity of that document.

State of California
County of Riverside)

On April 18th, 2022 before me, Jodie Atha, Notary Public
(insert name and title of the officer)

personally appeared Edgar Gomez,
who proved to me on the basis of satisfactory evidence to be the person(s) whose name(s) is/are subscribed to the within instrument and acknowledged to me that he/she/they executed the same in his/her/their authorized capacity(ies), and that by his/her/their signature(s) on the instrument the person(s), or the entity upon behalf of which the person(s) acted, executed the instrument.

I certify under PENALTY OF PERJURY under the laws of the State of California that the foregoing paragraph is true and correct.

WITNESS my hand and official seal.

Signature Jodie Atha (Seal)

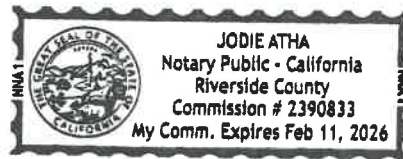

CERTIFICATE OF RESOLUTION

I, Joseph H. Fretz, as Secretary of Richmond American Homes of Maryland, Inc., a Maryland corporation (the "Company"), do hereby certify on behalf of the Company that the following resolutions were adopted by the Board pursuant to Minutes of Action dated as of February 10, 2020, and that such resolutions are in full force and effect as of the date of this Certificate of Resolution:

RESOLVED, that the Company hereby appoints Edgar Gomez as Vice President – Project Management (Land) (Riverside Division), effective as of January 18, 2020, to serve until his successor is duly appointed or until the earlier of his resignation, retirement, termination of his employment, or death; and it is

FURTHER RESOLVED, that Edgar Gomez as an officer of the Company is authorized hereby to enter into and execute and deliver, on behalf of the Company, any and all documents necessary or advisable in connection with his position as Vice President – Project Management (Land) (Riverside Division).

RICHMOND AMERICAN HOMES OF
MARYLAND, INC., a Maryland corporation

By: 
Joseph H. Fretz, Secretary

Executed at Denver, Colorado this 13TH day of February 2020.

CITY OF BEAUMONT PUBLIC WORKS DEPARTMENT
 CONSTRUCTION COST WORKSHEET
 "PLAN CHECK FEE EST"

PARCEL MAP OR TRACT NO.: PA-25 Tr 37696 Storm Drain Plans
 DATE: 4/9/2021
 PP, CUP NO.: _____ BY: George A. Lenfestey

IMPROVEMENTS	FAITHFUL PERFORMANCE	100%
	LABOR & MATERIALS SECURITY	100%
Construction Costs)		
Streets/Drainage	\$	49,392.50
Sewer	\$	-
Total	\$	49,392.50
Warranty Retention (22.5%)	\$	11,113.31
Street/Drainage Plan Check Fees =	\$	2,469.63
Sewer Plan Check Fees =	\$	500.00
Street Inspection Fees =	\$	3,704.44
Sewer Inspection Fees =	\$	750.00

DESIGN ENGINEERS CALCULATIONS OF IMPROVEMENT BONDING COSTS

Construction items and their quantities as shown on attached sheets are accurate for the improvements required to construct the above project and the mathematical extensions using City's unit costs are accurate for determining bonding, plan check and inspection costs.

Above amounts do include additional 20% for recordation prior to having signed plans

Above amounts do not include additional 20% for recordation prior to having signed plans

George A. Lenfestey
 Engineer's Signature

9-Apr-21
 Date



George A. Lenfestey
 Name typed or printed

Civil Engineer's Stamp

*****PLEASE READ INSTRUCTIONS BELOW*****

- Quantities to be taken from improvement plans, Unit costs to be as provided on "City of Beaumont Construction Cost Worksheet".
- Show Bond Amounts to the nearest \$500.
- For construction items not covered by the Construction Cost Worksheet", Design Engineer is to provide his opinion of construction cost and use of that cost. If City of Beaumont unit costs are determined to be too low in the opinion of the Design Engineer, the higher costs as provided by the Design Engineer should be used.

CITY OF BEAUMONT PUBLIC WORKS DEPARTMENT
IMPROVEMENT REQUIREMENT WORKSHEET

PROJECT: PA-25 Tr 37696 Storm Drain Plans

DATE: 9-Apr-21

STREET IMPROVEMENTS (Cont'd.)				
QTY.	UNIT	ITEM	UNIT COST	AMOUNT
	L.F.	Remove Chain Link Fence	\$ 2.50	\$ -
	EA.	Remove Barricade	\$ 200.00	\$ -
	TON	Asphalt Concrete - 144 lbs/cu. Ft. (-- SF @ 0.33')	\$ 90.00	\$ -
	C.Y.	Aggregate Base Class II (-- SF@0.50')	\$ 50.00	\$ -
	TON	Asphalt Emulsion (Fog Seal/Paint Binder) (1 ton = 240 gals) (-- SF)	\$ 600.00	\$ -
		apply at 0.05 + 0.03 = 0.08 gal/SY		\$ -
	S.F.	AC overlay (min. 0.10') If export, provide (a) & (b), a=fill, b=cut-fill If import, provide (a)&(C), a=cut, c=fill-cut (Unit costs for (a), (b) & (C) are 20% of actual costs to assure that work will be corrected to eliminate hazardous conditions.)	\$ 0.90	\$ -
	S.F.	Remove A.C. Pavement	\$ 0.50	\$ -
	L.F.	Curb and Gutter (Wedge Curb)	\$ 8.00	\$ -
	L.F.	Curb and Gutter (Type A-6)	\$ 10.00	\$ -
	L.F.	Curb and Gutter (Type A-8)	\$ 12.00	\$ -
	L.F.	Type "C" Curb	\$ 10.00	\$ -
	L.F.	Type "D" Curb	\$ 15.00	\$ -
	L.F.	A.C. Dike (6") (incl. material & labor)	\$ 8.00	\$ -
	L.F.	A.C. Dike (8") (incl. Material & labor)	\$ 10.00	\$ -
	S.F.	P.C.C. Cross Gutter and Spandrels	\$ 10.00	\$ -
	S.F.	P.C.C. Sidewalk	\$ 6.00	\$ -
	SF	P.C.C. Drive Approach (16' Wide)	\$ 8.00	\$ -
	EA.	Handicapped Access Ramp	\$ 1,500.00	\$ -
	EA.	P.C.C. Drive Approach (individual lot driveway approach per finished grading plan)	\$ 8.00	\$ -
	S.F.	Join Existing Pavement (Grind & Overlay Exist. A.C.)	\$ 4.00	\$ -
				\$ -
				\$ -
				\$ -

SUBTOTAL = \$ -

CITY OF BEAUMONT PUBLIC WORKS DEPARTMENT
IMPROVEMENT REQUIREMENT WORKSHEET

PROJECT: PA-25 Tr 37696 Storm Drain Plans

DATE: 9-Apr-21

STREET IMPROVEMENTS (Cont'd.)				
QTY.	UNIT	ITEM	UNIT COST	AMOUNT
	EA.	Street Name Sign	\$ 250.00	\$ -
	EA.	Delineators-per Caltrans Std. A73C, Class 1, Type F	\$ 40.00	\$ -
	EA.	Object Markers - Modified Type F Delineators, Riverside County	\$ 40.00	\$ -
	L.F.	Barricades	\$ 28.00	\$ -
	L.F.	Utility Trench, one side (Edison, Telephone, Cable) (1`/2 Total length of streets)	\$ 10.00	\$ -
	L.F.	Chain Link Fence (6')	\$ 12.00	\$ -
	L.F.	Remove Fence	\$ 4.00	\$ -
	EA.	Remove Power Pole	\$ 1,200.00	\$ -
	EA.	Street Lights (including conduit)	\$ 5,000.00	\$ -
	EA.	Street Trees (15 gallon)	\$ 150.00	\$ -
1	EA.	Remove Existing Concrete Bulkhead	\$ 500.00	\$ 500
	EA.	Concrete Bulkhead	\$ 200.00	\$ -
	C.Y.	Structural Reinforced Concrete	\$ 400.00	\$ -
	EA.	Slope Anchors for Pipes	\$ 300.00	\$ -
	L.F.	Cut Off Wall (Std. 2')	\$ 5.50	\$ -
	EA.	A.C. Overside Drain	\$ 500.00	\$ -
	EA.	Under Sidewalk Drain	\$ 1,800.00	\$ -
	S.F.	Terrace Drains and Down Drains	\$ 6.50	\$ -
	S.F.	Interceptor Drains	\$ 6.50	\$ -
	EA.	Gutter Depression for Curb Opening Catch Basin Case B	\$ 1,500.00	\$ -
	EA.	Gutter Depression for Curb Opening Catch Basin Case C	\$ 1,500.00	\$ -
	EA.	Access Driveway for Storm Drain at Cul-de-Sac	\$ 640.00	\$ -
	EA.	"STOP" Pavement Marking	\$ 200.00	\$ -
	EA.	Limit Line	\$ 75.00	\$ -
	EA.	R1 "STOP SIGN"	\$ 250.00	\$ -
	EA.	W14-1 "DEAD END" Sign	\$ 250.00	\$ -
	EA.	S4-5 "SCHOOL ZONE AHEAD" sign	\$ 250.00	\$ -
	EA.	SR4-1(CA) "SCHOOL ZONE" sign	\$ 250.00	\$ -

SUBTOTAL = \$ 500.00

CITY OF BEAUMONT PUBLIC WORKS DEPARTMENT
IMPROVEMENT REQUIREMENT WORKSHEET

PROJECT: PA-25 Tr 37696 Storm Drain Plans

DATE: 9-Apr-21

STREET IMPROVEMENTS (Cont'd.)				
QTY.	UNIT	ITEM	UNIT COST	AMOUNT
	C.Y.	Rip Rap (1/4 Ton) Method B	\$ 35.00	\$ -
	C.Y.	Rip Rap (1/2 Ton) Method B	\$ 40.00	\$ -
	C.Y.	Rip Rap (1 Ton) Method B	\$ 45.00	\$ -
	C.Y.	Rip Rap (2 Ton) Method B	\$ 50.00	\$ -
	C.Y.	Grouted Rip Rap (1/4 Ton) Method B	\$ 45.00	\$ -
	C.Y.	Grouted Rip Rap (1/2 Ton) Method B	\$ 55.00	\$ -
	C.Y.	Grouted Rip Rap (1Ton) Method B	\$ 60.00	\$ -
	C.Y.	Grouted Rip Rap (2 Ton) Method B	\$ 65.00	\$ -
135	L.F.	18" R.C.P.	\$ 60.00	\$ 8,100
130	L.F.	24" R.C.P.	\$ 70.00	\$ 9,100
	L.F.	30" R.C.P.	\$ 80.00	\$ -
	L.F.	36" R.C.P.	\$ 90.00	\$ -
	L.F.	42" R.C.P.	\$ 100.00	\$ -
	L.F.	48 " RCP	\$ 110.00	\$ -
	L.F.	54" RCP	\$ 135.00	\$ -
	L.F.	60" RCP	\$ 160.00	\$ -
	L.F.	72" RCP	\$ 200.00	\$ -
	EA.	H.D.P.E. Clean Out	\$ 400.00	\$ -
	EA.	Drain Basin	\$ 400.00	\$ -
	EA.	Curb Outlet	\$ 3,000.00	\$ -
	EA.	Fossil Filters	\$ 500.00	\$ -
	EA.	18" C.M.P. Wye	\$ 500.00	\$ -
	EA.	Riprap Headwall	\$ 1,000.00	\$ -
	EA.	Concrete Collar	\$ 250.00	\$ -
	EA.	Outlet Structure	\$ 10,000.00	\$ -
	EA.	Concrete Pipe Anchor & Stabilizer	\$ 250.00	\$ -
	L.F.	12" HDPE. Pipe	\$ 31.00	\$ -
	EA.	12" HDPE Misc. Fittings (Bend, coupling & end cap)	\$ 320.00	\$ -

SUBTOTAL = \$ 17,200.00

CITY OF BEAUMONT PUBLIC WORKS DEPARTMENT
IMPROVEMENT REQUIREMENT WORKSHEET

PROJECT: PA-25 Tr 37696 Storm Drain Plans

DATE: 9-Apr-21

STREET IMPROVEMENTS (Cont'd.)				
QTY.	UNIT	ITEM	UNIT COST	AMOUNT
	L.F.	60" C.S.P.	\$ 115.00	\$ -
	EA.	Catch Basin W = 4'	\$ 1,700.00	\$ -
	EA.	Catch Basin W = 7'	\$ 3,000.00	\$ -
	EA.	Catch Basin W = 10'	\$ 4,000.00	\$ -
3	EA.	Catch Basin W = 14'	\$ 5,500.00	\$ 16,500
	EA.	Catch Basin W = 21'	\$ 9,000.00	\$ -
	EA.	Type IX Inlet	\$ 2,500.00	\$ -
	EA.	Type X Inlet	\$ 2,500.00	\$ -
	EA.	Junction Structure No. 1	\$ 3,000.00	\$ -
	EA.	Junction Structure No. 2	\$ 2,500.00	\$ -
	EA.	Junction Structure No. 6	\$ 3,700.00	\$ -
	EA.	Transition Structure No. 1	\$ 2,000.00	\$ -
	EA.	Transition Structure No. 3	\$ 2,700.00	\$ -
1	EA.	Manhole No. 1 (Modified)	\$ 2,700.00	\$ 2,700
	EA.	Manhole No. 2	\$ 3,300.00	\$ -
	EA.	Manhole No. 3	\$ 2,700.00	\$ -
1	EA.	Manhole No. 4	\$ 5,000.00	\$ 5,000
	EA.	Adjust Water Valve (if no water plan)	\$ 150.00	\$ -
	EA.	Adjust MH to grade (if no sewer plan)	\$ 400.00	\$ -
	EA.	Headwall	\$ 5,000.00	\$ -
		Remove & Dispose of Interferring 30" Storm Drain		
	L.S.	and 36" Riser	\$ 500.00	\$ -
	EA.	Remove & Dispose of RCB Headwall & Wingwall	\$ 10,000.00	\$ -
	L.F.	and Concrete Bulkhead	\$ 25.00	\$ -
	EA.	Outlet Structure (Line A & B)	\$ 5,000.00	\$ -
	EA.	Remove Existing Headwall	\$ 1,000.00	\$ -
3	EA.	Catch Basin Trash Rack	\$ 350.00	\$ 1,050
				\$ -
				\$ -
				\$ -
				\$ -
SUBTOTAL =			\$	25,250

CITY OF BEAUMONT PUBLIC WORKS DEPARTMENT
IMPROVEMENT REQUIREMENT WORKSHEET

PROJECT: PA-25 Tr 37696 Storm Drain Plans

DATE: 9-Apr-21

STREET IMPROVEMENTS (Cont'd.)				
QTY.	UNIT	ITEM	UNIT COST	AMOUNT
	EA.	Water Quality Structure	\$ 2,500.00	\$ -
	LS	Concrete Inlet Apron	\$ 11,000.00	\$ -
	LS	Emergency Spillway	\$ 27,000.00	\$ -
	LS	84" Storm Drain Grate	\$ 8,500.00	\$ -
	SF	3' Wide V-Gutter (945 LF)	\$ 4.00	\$ -
				\$ -
				\$ -
				\$ -
				\$ -
				\$ -

Subtotal: \$ -

A. Subtotal \$ 42,950

B. Contingency (15%) \$ 6,443

C. Streets/Drainage Total (A + B) \$ 49,393

CITY OF BEAUMONT PUBLIC WORKS DEPARTMENT
IMPROVEMENT REQUIREMENT WORKSHEET

PROJECT: PA-25 Tr 37696 Storm Drain Plans

DATE: 9-Apr-21

SEWER IMPROVEMENTS

Show quantities on this sheet only if project has a sewer plan. If no water plan, then show applicable quantities as part of street improvements.

QTY.	UNIT	ITEM	UNIT COST	AMOUNT
	L.F.	4" PVC. (73 Lots @ 25' Avg. Length & 5' for cleanout)	\$ 15.00	\$ -
	L.F.	4" P.V.C. Force Main & Fittings	\$ 26.00	\$ -
	L.F.	8" PVC	\$ 30.00	\$ -
	L.F.	10" V.C.P.	\$ 35.00	\$ -
	L.F.	12" V.C.P.	\$ 40.00	\$ -
	L.F.	15" V.C.P.	\$ 50.00	\$ -
	EA.	Standard or Terminus Manholes	\$ 2,500.00	\$ -
	EA.	Modified 5' Manholes	\$ 3,000.00	\$ -
	EA.	Drop Manholes	\$ 4,000.00	\$ -
	EA.	Sewer Lateral Connection per RCTD No. 600	\$ 500.00	\$ -
	EA.	Sewer Y's	\$ 25.00	\$ -
	EA.	Chimneys	\$ 300.00	\$ -
	EA.	Adjust M.H. to grade	\$ 340.00	\$ -
	L.F.	Concrete Encasement	\$ 20.00	\$ -
	EA.	4" P.V.C. Misc. Fittings	\$ 120.00	\$ -
	L.F.	Sewer Pipe Sleeving	\$ 36.00	\$ -
	EA.	Sewer Lift Station		\$ -
	EA.	Backflow prevention device	\$ 250.00	\$ -
	EA.	8" P.V.C. Misc. Fittings & Plugs	\$ 190.00	\$ -
	EA.	Remove 8" P.V.C Plug	\$ 190.00	\$ -

A.	Subtotal	\$	-
B.	Contingency (15% x A)	\$	-
C.	Sewer Total (A + B)	\$	-

STORM DRAIN NOTES:

- 1. THE CONTRACTOR SHALL CONSTRUCT THE DRAINAGE IMPROVEMENT SHOWN ON THE DRAWINGS IN CONFORMANCE WITH THE REQUIREMENTS OF THE RIVERSIDE COUNTY FLOOD CONTROL AND WATER CONSERVATION DISTRICT DESIGN MANUAL STANDARD DRAWINGS, RECENT EDITION, AND IN CONFORMANCE WITH THE REQUIREMENTS OF THE BEAUMONT DRAINAGE MANAGEMENT PLAN.
2. THE CONTRACTOR IS REQUIRED TO CONTACT ALL UTILITY AGENCIES REGARDING TEMPORARY SUPPORT AND SHORING REQUIREMENTS FOR THE SHARPOUR UTILITIES SHOWN IN THE PLANS. CONSTRUCTION INSPECTION WILL BE PERFORMED BY CITY OF BEAUMONT. CONTACT (951) 789-8520. THE CITY MUST BE NOTIFIED ONE WEEK PRIOR TO CONSTRUCTION.
3. ALL STATIONING REFERS TO THE CENTERLINE OF CONSTRUCTION UNLESS OTHERWISE NOTED. STATIONING FOR LATERALS AND CONNECTOR PIPE REFER TO THE CENTERLINE-CENTERLINE-INTERSECTION STATION.
4. FORTY-EIGHT HOURS BEFORE EXCAVATION, CALL UNDERGROUND SERVICE ALERT 1-800-227-2600.
5. ALL CROSS SECTIONS ARE TAKEN LOOKING UPSTREAM.
6. ELEVATIONS AND LOCATIONS OF UTILITIES SHOWN ARE APPROXIMATE UNLESS OTHERWISE NOTED. ALL UTILITIES SHOWN ARE TO BE PROTECTED IN PLACE UNLESS OTHERWISE NOTED. OPENINGS RESULTING FROM THE CUTTING OR PARTIAL REMOVAL OF EXISTING CULVERTS, PIPES OR SIMILAR STRUCTURES TO BE ABANDONED SHALL BE SEALED WITH 6 INCHES OF CLASS "B" CONCRETE.
7. PIPE CONNECTED TO THE MAINLINE PIPE SHALL CONFORM TO JUNCTION STRUCTURE NO. 4 (JS 229) UNLESS OTHERWISE NOTED.
8. PIPE BEDDING SHALL CONFORM TO R.C.F.C. & W.C.D. STD. DWG. M 815
9. "Y" IS THE DEPTH OF INLET AT THE CATCH BASINS MEASURED FROM THE TOP OF THE CURB TO THE INVERT OF CONNECTOR PIPE.
10. ALL CURBS, GUTTERS, SIDEWALKS, DRIVEWAYS, AND OTHER EXISTING IMPROVEMENTS TO BE RECONSTRUCTED IN KIND PER LATEST COUNTY STANDARD AND AT THE SAME ELEVATION AND LOCATION AS THE EXISTING IMPROVEMENTS UNLESS OTHERWISE NOTED. FOR PAVEMENT OVERLAY, 0.10" MIN. FOR FULL LANE WIDTH IS REQUIRED.
11. HYDRAULIC GRADE LINES SHOWN IN PROFILES ARE FOR 100 YEAR FREQUENCY FLOWS, UNLESS OTHERWISE NOTED.
12. THE CONTRACTOR SHALL COMPLY WITH THE STATE AND LOCAL SAFETY CODES DURING THE PROGRESS OF WORK.
13. THE CONTRACTOR SHALL MAINTAIN ADJACENT STREETS IN A NEAT, SAFE, CLEAN AND SANITARY CONDITION AT ALL TIMES AND TO THE SATISFACTION OF THE COUNTY'S OR DISTRICT'S INSPECTOR. THE ADJACENT STREETS SHALL BE KEPT CLEAN OF DEBRIS, WITH DUST AND OTHER NUISANCE BEING CONTROLLED AT ALL TIMES. THE DEVELOPER SHALL BE RESPONSIBLE FOR ANY CLEAN UP ON ADJACENT STREETS AFFECTED BY HIS CONSTRUCTION. METHOD OF STREET CLEANING SHALL BE DRY SWEEPING OF ALL PAVED AREAS.
14. THE CONTRACTOR AGREES THAT HE/SHE SHALL ASSUME SOLE AND COMPLETE RESPONSIBILITY FOR THE JOB SITE CONDITIONS DURING THE COURSE OF CONSTRUCTION OF THIS PROJECT, INCLUDING SAFETY OF ALL PERSONS AND PROPERTY, THAT THIS REQUIREMENT SHALL APPLY CONTINUOUSLY AND NOT BE LIMITED TO NORMAL WORKING HOURS AND THAT THE CONTRACTOR SHALL DEFEND, INDEMNIFY AND HOLD THE OWNER, CITY OF BEAUMONT, AND THE DEVELOPER'S ENGINEER, HARMLESS FROM ANY AND ALL LIABILITY, REAL OR ALLEGED, IN CONNECTION WITH THE PERFORMANCE OF WORK ON THIS PROJECT EXCEPTING FOR LIABILITY ARISING FROM THE SOLE NEGLIGENCE OF THE OWNERS OR THE DEVELOPER'S ENGINEER.
15. ALL PIPE LENGTHS ARE HORIZONTAL PROJECTIONS (NOT TRUE LENGTHS OF PIPE) AND ARE THE BASIS OF THE ESTIMATES OF QUANTITIES. THE CONTRACTOR SHALL DETERMINE THE TRUE QUANTITY OF PIPE REQUIRED FOR THIS PROJECT PRIOR TO PLACING THE ORDER.
16. ALL ELEVATIONS SHOWN ARE TO THE INVERTS OF PIPE, EXCEPT WHERE OTHERWISE NOTED.
17. AT THE DISCRETION OF THE ENGINEER AND THE CITY OF BEAUMONT, THE CONTRACTOR MAY BE REQUIRED TO VERIFY, BY POTHOLES, THE LOCATION OF POTENTIALLY AFFECTED UTILITIES.
18. CONTRACTOR SHALL DISPOSE OF ALL EXCESS EXCAVATED MATERIAL AT MANDATORY DISPOSAL SITE.
19. ALL BACKFILL AND BEDDING AROUND STRUCTURES AND PIPES SHALL BE COMPACTED TO NOT LESS THAN 90 PERCENT RELATIVE COMPACTION EXCEPT WHERE SUCH MATERIAL IS PLACED UNDER EXISTING PAVED ROADWAYS. THE TOP 3 FEET, MEASURED FROM THE FINISH PAVING, SHALL BE COMPACTED TO 95 PERCENT RELATIVE COMPACTION.
20. ALL SURVEY MONUMENTS SHALL BE REPLACED AS REQUIRED. MONUMENTS SHALL BE TIED OUT PRIOR TO CONSTRUCTION AND REPLACED UPON COMPLETION OF CONSTRUCTION.
21. IT SHALL BE THE RESPONSIBILITY OF THE DEVELOPER/OWNER OR CONTRACTOR TO APPLY TO THE DIRECTOR OF PUBLIC WORKS, CITY OF BEAUMONT FOR AN ENCROACHMENT PERMIT FOR ALL WORK PERFORMED WITHIN PUBLIC RIGHT-OF-WAY, DEDICATED AND ACCEPTED FOR PUBLIC USE; AND TO BE RESPONSIBLE FOR SATISFACTORY COMPLIANCE FOR ALL CURRENT ENVIRONMENTAL REGULATIONS DURING THE LIFE OF CONSTRUCTION ACTIVITIES FOR THIS PROJECT. ADDITIONAL STUDIES AND/OR PERMITS MAY BE REQUIRED.
22. THE CONTRACTOR SHALL BE RESPONSIBLE FOR THE CLEARING OF THE PROPOSED WORK AREA, AND RELOCATION COSTS OF ALL EXISTING UTILITIES. PERMITEE MUST INFORM CITY OF CONSTRUCTION SCHEDULE AT LEAST 48 HOURS PRIOR TO BEGINNING CONSTRUCTION.
23. ALL UNDERGROUND FACILITIES WITH LATERALS SHALL BE IN PLACE PRIOR TO PAVING THE STREET, INCLUDING BUT NOT LIMITED TO, THE FOLLOWING: SEWER, WATER, ELECTRIC, STORM DRAINS.
24. IT SHALL BE THE RESPONSIBILITY OF THE DEVELOPER OR CONTRACTOR TO INSTALL AND MAINTAIN DURING CONSTRUCTION, REGULATORY GUIDE AND WARNING SIGNS WITHIN THE PROJECT LIMITS AND ITS SURROUNDINGS TO PROVIDE SAFE PASSAGE FOR THE TRAVELING PUBLIC AND WORKERS UNTIL THE FINAL COMPLETION AND ACCEPTANCE OF THE PROJECT BY THE CITY OF BEAUMONT.
25. CONSTRUCTION PROJECTS THAT DISTURB MORE THAN ONE ACRE MUST OBTAIN A NATIONAL POLLUTANT DISCHARGE ELIMINATION SYSTEM (NPDES) PERMIT. OWNER/DEVELOPERS ARE REQUIRED TO FILE A NOTICE OF INTENT (NOI) WITH THE STATE WATER RESOURCES CONTROL BOARD (SWRCB) AND COMPLY WITH ALL REQUIREMENTS OF THE BEAUMONT DRAINAGE MANAGEMENT PLAN. BEAUMONT IS CO-PERMITTEE WITH R.C.F.C. & W.C.D.
26. ALL STORM DRAINS, CATCH BASINS, AND STORM WATER RUNOFF STRUCTURES WILL BE PROVIDED WITH ADEQUATE CAPABILITIES TO FILTER AND RETAIN SEDIMENT AND DIRT, OIL AND GREASE, TO PREVENT POLLUTION IN STORM WATER RUNOFF IN COMPLIANCE WITH THE CITY OF BEAUMONT'S BEST MANAGEMENT PRACTICES AND THE BEAUMONT DRAINAGE MASTER PLAN FOR STORM WATER AS WELL AS BEST MANAGEMENT PRACTICES IDENTIFIED IN THE CURRENT REPORT OF WASTE DISCHARGE FOR RIVERSIDE COUNTY PERMITEES.
27. DEVELOPER SHALL BE FULLY RESPONSIBLE IN ASSURING THAT PROPOSED IMPROVEMENTS CONFORM TO THE APPROVED PLANS, SPECIFICATIONS AND CITY OF BEAUMONT STANDARDS. WHERE DEVIATIONS EXIST, DEVELOPER SHALL PROPOSE CORRECTIVE MEASURES FOR REVIEW AND APPROVAL BY THE CITY.

PRIVATE ENGINEER'S NOTICE TO CONTRACTOR(S):

- 1. THE EXISTENCE AND LOCATION OF ANY UNDERGROUND UTILITIES OR STRUCTURES SHOWN ON THESE PLANS ARE OBTAINED BY A SEARCH OF AVAILABLE RECORDS. TO THE BEST OF OUR KNOWLEDGE, THERE ARE NO EXISTING UTILITIES EXCEPT THOSE SHOWN ON THESE PLANS. THE CONTRACTOR IS REQUIRED TO TAKE ALL PRECAUTIONARY MEASURES TO PROTECT THE UTILITIES SHOWN AND ANY OTHER LINES OR STRUCTURES NOT SHOWN ON THESE PLANS AND IS RESPONSIBLE FOR THE PROTECTION OF, AND ANY DAMAGE TO THESE LINES OR STRUCTURES.
2. IT SHALL BE THE CONTRACTOR'S RESPONSIBILITY TO NOTIFY THE OWNER OF ALL UTILITIES OR STRUCTURES CONCERNED BEFORE STARTING WORK.
3. QUANTITIES SHOWN HEREON ARE PROVIDED FOR BIDDING PURPOSES ONLY. CONTRACTOR SHALL BE RESPONSIBLE FOR VERIFYING QUANTITIES PRIOR TO BIDDING FOR CONSTRUCTION.
4. THE PRIVATE ENGINEER SIGNING THESE PLANS IS RESPONSIBLE FOR ASSURING THE ACCURACY AND ACCEPTABILITY OF THE DESIGN HEREON. IN THE EVENT OF DISCREPANCIES ARISING AFTER CITY APPROVAL OR DURING CONSTRUCTION, THE PRIVATE ENGINEER SHALL BE RESPONSIBLE FOR DETERMINING AN ACCEPTABLE SOLUTION AND REVISE THE PLANS FOR APPROVAL BY THE CITY.

*RCP NOTE:

- 1. THE CONCRETE COATING ON THE INSIDE OF ALL REINFORCED CONCRETE PIPES MUST BE INCREASED TO PROVIDE A MINIMUM OF 1-1/2" OVER THE REINFORCING WHEN THE DESIGN VELOCITIES EXCEED 20 FEET PER SECOND. THE CONCRETE DESIGN STRENGTH IN THESE REACHES SHALL BE Fc = 5,000 PSI FOR VELOCITIES EXCEEDING 20 FEET PER SECOND AND Fc = 6,000 PSI FOR VELOCITIES EXCEEDING 30 FPS.
2. JOINTS FOR REINFORCED CONCRETE PIPES UNDER PRESSURE FLOW CONDITIONS SHALL BE WATERTIGHT IN CONFORMANCE WITH ASTM C443.

GENERAL NOTES:

- 1. THIS PLAN SUPERSEDES ALL OTHER PLANS PREVIOUSLY APPROVED BY THE CITY OF BEAUMONT REGARDING IMPROVEMENTS SHOWN ON THIS SET OF PLANS.
2. APPROVAL OF THIS PLAN DOES NOT LESSEN OR WAIVE ANY PORTION OF THE BEAUMONT MUNICIPAL CODE, RESOLUTION OF CONDITIONAL APPROVAL, CITY STANDARDS OR OTHER ADDITIONAL DOCUMENTS LISTED HEREIN AS THEY MAY PERTAIN TO THIS PROJECT. THE ENGINEER IN RESPONSIBLE CHARGE SHALL REVISE THESE PLANS WHEN NON-CONFORMANCE IS DISCOVERED.
3. CITY APPROVAL OF PLANS DOES NOT RELIEVE THE DEVELOPER OR ENGINEER-OF-WORK FROM RESPONSIBILITY FOR THE CORRECTION OF ERRORS AND OMISSIONS DISCOVERED DURING CONSTRUCTION. ALL PLAN REVISIONS SHALL BE PROMPTLY SUBMITTED TO THE CITY ENGINEER FOR APPROVAL.
4. A RIGHT-OF-WAY PERMIT FROM THE BUILDING & SAFETY DEPARTMENT WILL BE REQUIRED FOR ANY WORK IN THE PUBLIC RIGHT OF WAY. PRIOR TO PERMIT ISSUANCE, A CERTIFICATE OF INSURANCE MUST BE FILED NAMING THE CITY OF BEAUMONT AS AN ADDITIONAL INSURED ON THE PERMITEE'S POLICY IN THE MINIMUM AMOUNT OF \$1,000,000.00 FOR EACH OCCURRENCE OF LIABILITY. THE INSURANCE COMPANY WRITING THE POLICY MUST HAVE A RATING OF "A-" OR BETTER AND A SIZE CATEGORY OF CLASS VI OR BETTER AS ESTABLISHED BY "BESTS" KEY RATING GUIDE.
5. NO WORK SHALL BE COMMENCED UNTIL ALL PERMITS HAVE BEEN OBTAINED FROM THE CITY AND OTHER APPROPRIATE AGENCIES.
6. REVISION OF THESE PLANS MAY BE REQUIRED IF THE PROPOSED IMPROVEMENTS ARE NOT CONSTRUCTED PRIOR TO THE DEADLINE DATE OF THE IMPROVEMENT AGREEMENT.
7. NO REVISIONS WILL BE MADE TO THESE PLANS WITHOUT THE WRITTEN APPROVAL OF THE CITY ENGINEER, NOTED WITHIN THE REVISION BLOCK, ON THE APPROPRIATE SHEET OF THE PLANS AND TITLE SHEET.
8. ORIGINAL DRAWINGS SHALL BECOME THE PROPERTY OF THE CITY UPON BEING SIGNED BY THE CITY ENGINEER.
9. THE ORIGINAL DRAWING SHALL BE REVISED TO REFLECT AS-BUILT CONDITIONS BY THE ENGINEER-OF-WORK PRIOR TO FINAL ACCEPTANCE OF THE WORK BY THE CITY.
10. ACCESS FOR FIRE AND OTHER EMERGENCY VEHICLES SHALL BE MAINTAINED TO THE PROJECT SITE AT ALL TIMES DURING CONSTRUCTION.
11. WHERE TRENCHES ARE WITHIN CITY EASEMENTS, A SOILS REPORT COMPRISED OF: A. SUMMARY SHEET B. LABORATORY WORK SHEETS C. COMPACTION CURVES, SHALL BE SUBMITTED BY A PROFESSIONAL ENGINEER OF THE STATE OF CALIFORNIA, PRINCIPALLY DOING BUSINESS IN THE FIELD OF APPLIED SOILS MECHANICS. THE SOILS REPORT WILL BE SUBMITTED TO THE CITY ENGINEERING INSPECTOR WITHIN TWO WORKING DAYS OF COMPLETION OF FIELD TESTS. THE WRITTEN FIELD COMPACTION REPORT(S) SHALL BE IMMEDIATELY SUBMITTED TO THE CITY ENGINEERING INSPECTOR UPON COMPLETION OF THE FIELD TESTS.
12. A PRECONSTRUCTION MEETING SHALL BE HELD AT THE SITE PRIOR TO THE BEGINNING OF WORK AND SHALL BE ATTENDED BY ALL REPRESENTATIVES RESPONSIBLE FOR CONSTRUCTION, INSPECTION, SUPERVISION, TESTING AND ALL OTHER ASPECTS OF THE WORK. THE CONTRACTOR SHALL SCHEDULE THE MEETING BY CALLING THE INSPECTION LINE AT (951) 572-3224 AT LEAST FIVE (5) WORKING DAYS PRIOR TO STARTING CONSTRUCTION. APPROVED DRAWINGS MUST BE AVAILABLE PRIOR TO SCHEDULING.
13. ALL INSPECTION REQUESTS OTHER THAN FOR THE PRECONSTRUCTION MEETING WILL BE MADE BY CALLING THE BUILDING AND SAFETY INSPECTION REQUEST LINE AT (951) 572-3224. INSPECTION REQUESTS MUST BE RECEIVED PRIOR TO 2:00 P.M. ON THE DAY BEFORE THE INSPECTION IS NEEDED. INSPECTIONS WILL BE MADE THE NEXT WORK DAY UNLESS YOU REQUEST OTHERWISE. REQUESTS MADE AFTER 2:00 P.M. WILL BE SCHEDULED FOR TWO FULL WORK DAYS LATER.
14. THE OWNER AND/OR APPLICANT THROUGH THE DEVELOPER AND/OR CONTRACTOR SHALL DESIGN, CONSTRUCT AND MAINTAIN ALL SAFETY DEVICES, INCLUDING SHORING, AND SHALL BE SOLELY RESPONSIBLE FOR CONFORMING TO ALL LOCAL, STATE AND FEDERAL SAFETY AND HEALTH STANDARDS, LAWS AND REGULATIONS.
15. THE CONTRACTOR SHALL CONFORM TO LABOR CODE SECTION 6705 BY SUBMITTING A DETAILED PLAN TO THE CITY ENGINEER AND/OR CONCERNED AGENCY SHOWING THE DESIGN OF SHORING, BRACING, SLOPE OR OTHER PROVISIONS TO BE MADE OF WORKER PROTECTION DURING THE HAZARD OF CAVING GROUND DURING THE INSTALLATION OF SUCH TRENCH OR TRENCHES OR DURING THE PIPE INSTALLATION THEREIN. THIS PLAN MUST BE PREPARED FOR ALL TRENCHES FIVE FEET (5') OR MORE IN DEPTH AND APPROVED BY THE CITY ENGINEER AND/OR CONCERNED AGENCY PRIOR TO EXCAVATION. IF THE PLAN VARIES FROM THE SHORING SYSTEM STANDARDS ESTABLISHED BY THE CONSTRUCTION SAFETY ORDERS, TITLE 8 CALIFORNIA ADMINISTRATIVE CODE, THE PLAN SHALL BE PREPARED BY A REGISTERED ENGINEER AT THE CONTRACTOR'S EXPENSE. A COPY OF THE OSHA EXCAVATION PERMIT MUST BE SUBMITTED TO THE INSPECTOR PRIOR TO EXCAVATION.
16. IF ANY ARCHAEOLOGICAL RESOURCES ARE DISCOVERED WITHIN ANY WORK ZONE DURING CONSTRUCTION, OPERATIONS WILL CEASE IMMEDIATELY, AND THE PERMITEE WILL NOTIFY THE CITY ENGINEER. OPERATIONS WILL NOT RESTART UNTIL THE PERMITEE HAS RECEIVED WRITTEN AUTHORITY FROM THE CITY ENGINEER TO DO SO.
17. ALL OPERATIONS CONDUCTED ON THE SITE OR ADJACENT THERETO SHALL ADHERE TO THE NOISE ORDINANCE SET FORTH BY THE CITY MUNICIPAL CODE. ALL OPERATIONS SHALL BE LIMITED BY THE NOISE ORDINANCE TO THE LEVEL OF DECIBELS SPECIFIED FOR THE AREA AND TIME PERIOD. CONSTRUCTION ACTIVITIES WILL BE LIMITED TO THE PERIOD BETWEEN 7:00 A.M. AND 6:00 P.M. EACH DAY MONDAY THROUGH FRIDAY, UNLESS OTHERWISE PERMITTED.
18. ALL OFF-SITE HAUL ROUTES SHALL BE SUBMITTED BY THE CONTRACTOR TO THE CITY ENGINEER FOR APPROVAL TWO FULL WORKING DAYS PRIOR TO BEGINNING OF WORK. THE CONTRACTOR SHALL BE RESPONSIBLE FOR ANY DEBRIS OR DAMAGE OCCURRING ALONG THE HAUL ROUTE OR ADJACENT STREETS AS A RESULT OF THE GRADING OPERATION.
19. NO BLASTING SHALL BE COMMENCED WITHOUT A CITY ENGINEER APPROVED BLASTING PROGRAM AND BLASTING PERMIT.

CITY OF BEAUMONT, CALIFORNIA
STORM DRAIN IMPROVEMENT PLANS
TRACT NO. 37696

NOTES:

- 1. APPROVAL OF THESE PLANS APPLY ONLY WITHIN THE JURISDICTION OF THE CITY OF BEAUMONT.
2. TRENCHING FOR UTILITIES AND STRUCTURES IS NOT ALLOWED UNTIL SOIL COMPACTION REPORT IS SUBMITTED AND APPROVED BY THE PUBLIC WORKS DEPARTMENT.
3. THE CITY RESERVES THE RIGHT TO REQUIRE REVISION OF THE APPROVED PLANS TO CONFORM WITH CURRENT STANDARDS AND TO POST A NEW BOND IF CONSTRUCTION HAS NOT COMMENCED WITHIN TWO YEARS AFTER PLANS WERE APPROVED.
4. THE DEVELOPER SHALL HAVE GEOTECHNICAL/SOILS ENGINEERING FIRM OBSERVE TRENCHING, BACKFILLING, AND SOIL COMPACTION OF ALL UTILITY TRENCHES WITHIN ALL EASEMENTS AND ROAD RIGHTS OF WAY. TWO SETS OF COMPACTION REPORTS CERTIFYING THAT WORKS WERE DONE IN CONFORMANCE TO STANDARDS AND GEOTECHNICAL REPORT SHALL BE SUBMITTED AFTER EACH UTILITY TRENCH IS COMPLETED AND CERTIFIED. COMPACTION REPORT MUST BE SUBMITTED TO THE DEPT. OF PUBLIC WORKS AT LEAST TWO WORKING DAYS BEFORE AGGREGATE BASE MATERIALS ARE PLACED ONSITE.

DECLARATION OF ENGINEER OF RECORD:

I HEREBY DECLARE THAT IN MY PROFESSIONAL OPINION, THE DESIGN OF THE IMPROVEMENTS AS SHOWN ON THESE PLANS COMPLIES WITH THE CURRENT PROFESSIONAL ENGINEERING STANDARDS AND PRACTICES. AS THE ENGINEER IN RESPONSIBLE CHARGE OF THE DESIGN OF THESE IMPROVEMENTS, I ACCEPT FULL RESPONSIBILITY FOR SUCH DESIGN. I UNDERSTAND AND ACKNOWLEDGE THAT THE PLAN CHECK OF THESE PLANS BY THE CITY OF BEAUMONT IS A REVIEW FOR THE LIMITED PURPOSE OF ENSURING THAT THESE PLANS COMPLY WITH THE CITY PROCEDURES AND OTHER APPLICABLE CODES AND ORDINANCES. THE PLAN REVIEW PROCESS IS NOT A DETERMINATION OF THE TECHNICAL ADEQUACY OF THE DESIGN OF THE IMPROVEMENTS. SUCH PLAN CHECK DOES NOT THEREFORE RELIEVE ME OF MY DESIGN RESPONSIBILITY.

AS THE ENGINEER OF RECORD, I AGREE TO DEFEND AND INDEMNIFY THE CITY OF BEAUMONT, ITS OFFICERS, ITS AGENTS, AND ITS EMPLOYEES FROM ANY AND ALL LIABILITY, CLAIMS, DAMAGES, OR INJURIES TO ANY PERSON OR PROPERTY ARISING FROM NEGLIGENCE ACTS, ERRORS OR OMISSIONS OF THE ENGINEER OF RECORD, HIS EMPLOYEES, HIS AGENTS OR HIS CONSULTANTS.

Signature of George Alan Lenfestey, R.C.E. 45920, dated 04/09/21, expiration date 12/31/2022.

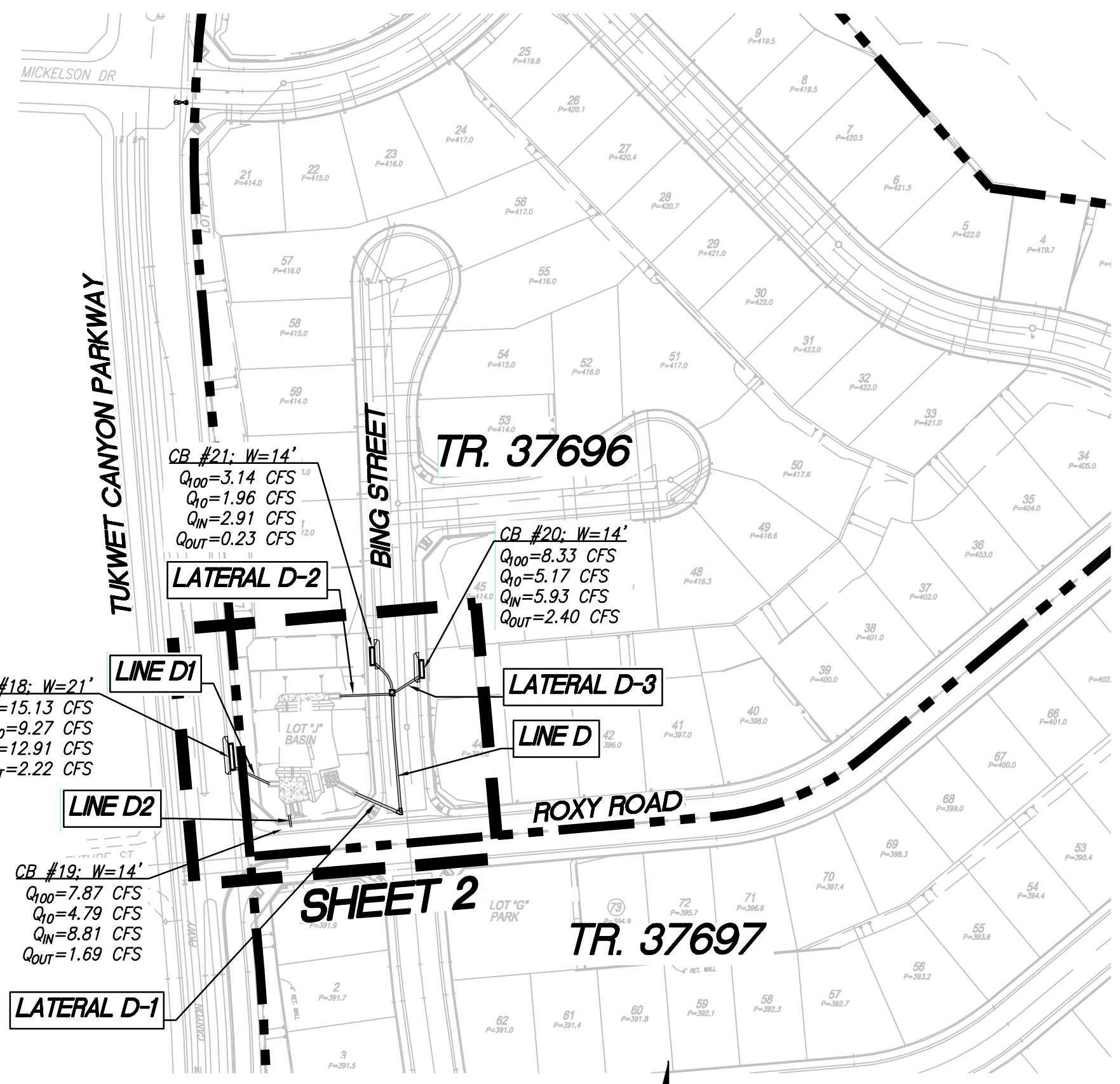

INDEX MAP

SCALE: 1"=100'

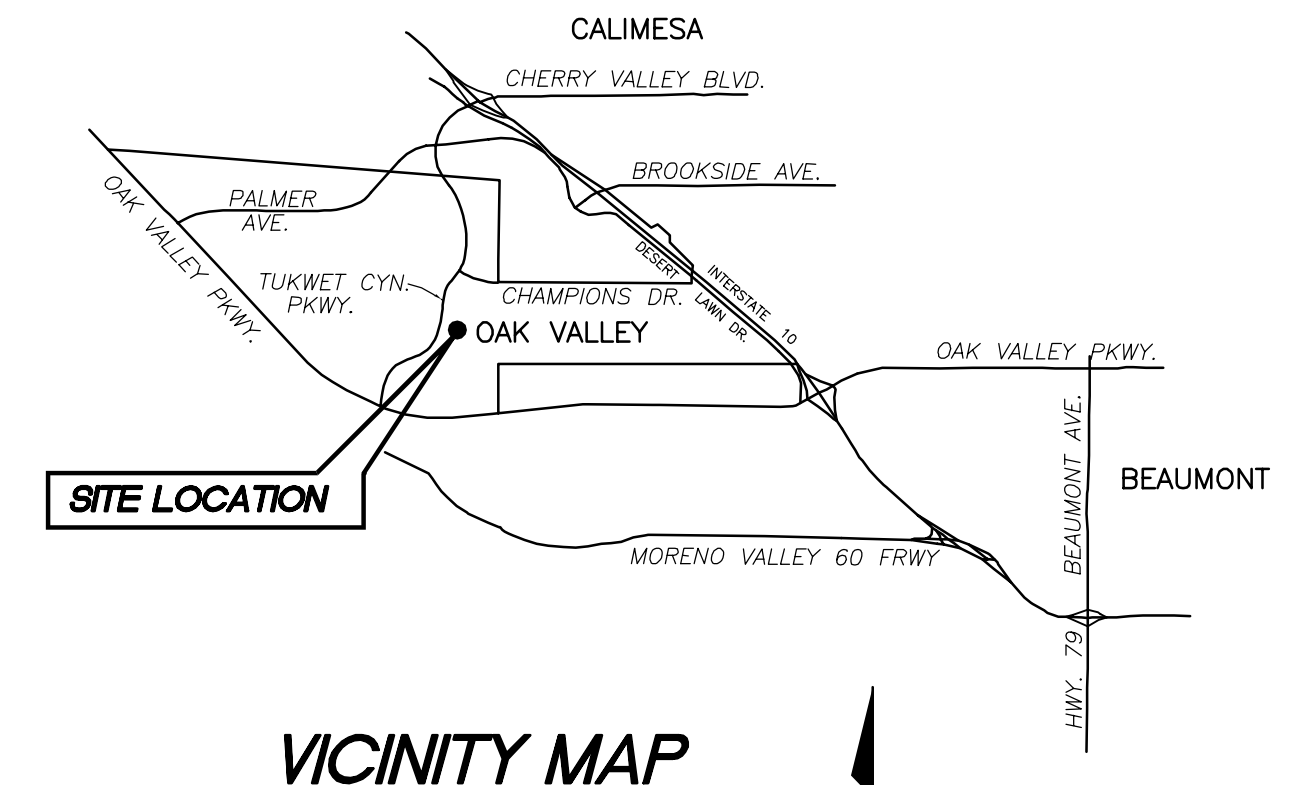

VICINITY MAP

NOT TO SCALE

ABBREVIATIONS:

Table listing abbreviations for engineering terms such as BC (BEGIN CURVE), EC (END CURVE), FPS (FEET PER SECOND), etc.

PREPARED BY:

PROACTIVE ENGINEERING CONSULTANTS WEST, INC. 25109 JEFFERSON AVENUE, SUITE 200 MURRIETA, CA 92562 PHONE: 951-200-6840

OWNER/DEVELOPER:

SDC FAIRWAY CANYON, LLC A DELAWARE LIMITED LIABILITY COMPANY 2392 MORSE AVENUE IRVINE, CA 92614 PHONE: 951-241-8403 CONTACT: CHERRYL THOMPSON

ASSESSOR'S PARCEL NUMBER:

413-790-020

LEGAL DESCRIPTION:

BEING A SUBDIVISION OF PARCEL "D" OF LOT LINE ADJUSTMENT NO. 04-LA-13, RECORDED OCTOBER 19, 2004, AS INSTRUMENT NO. 2004-0826803, OF OFFICIAL RECORDS OF RIVERSIDE COUNTY, LYRING WITH 36, T. 2 S., R. 2 W., S.B.B.M

LEGEND:

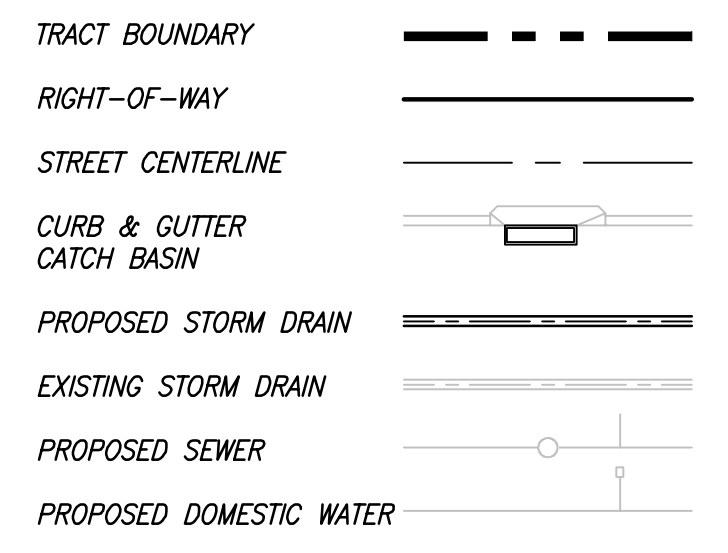

MAINTENANCE NOTE:

ALL STORM DRAIN FACILITIES PROPOSED ON THIS PLAN ARE MAINTAINED BY THE CITY OF BEAUMONT UNLESS OTHERWISE NOTED ON STORM DRAIN PROFILE.

DOWNSTREAM FACILITIES NOTE:

PROJECT IS REQUIRED TO CONSTRUCT DOWNSTREAM FACILITIES IF NOT CONSTRUCTED AT TIME OF CONNECTION.

INDEX OF SHEETS:

Table with columns for SHEET NO., DESCRIPTION, and QUANTITIES, listing sheets 1 and 2.

CONSTRUCTION NOTES:

- 1. INSTALL 18" RCP (D-LOAD PER PROFILE) 135 L.F.
2. INSTALL 24" RCP (D-LOAD PER PROFILE) 130 L.F.
3. CONSTRUCT MANHOLE #4 PER R.C.F.C. & W.C.D. STD. DWG. NO. MH254. 1 EA.
4. CONSTRUCT MODIFIED MANHOLE #1 PER R.C.F.C. & W.C.D. STD. DWG. NO. MH251. SEE DETAILS ON SHEET 2. 1 EA.
5. CONSTRUCT CURB INLET CATCH BASIN PER COUNTY OF RIVERSIDE STD. NO. 300, NOTE: LOCAL DEPRESSION PER TR. 37696 STREET IMPROVEMENT PLANS. 3 EA.
6. REMOVE EXISTING CONCRETE BULKHEAD 1 EA.
7. WASO1 OUTLET STRUCTURE PER TR. 37696 ROUGH GRADING PLANS 1 EA.
8. D89 HEADWALL PER TR. 37696 ROUGH GRADING PLANS 3 EA.

QTY

DIG ALERT logo and text: DIAL TOLL FREE 8-1-1 AT LEAST TWO DAYS BEFORE YOU DIG UNDERGROUND SERVICE ALERT OF SOUTHERN CALIFORNIA

BASIS OF BEARINGS: DESCRIPTION: THE BASIS OF COORDINATES FOR THIS MAP IS THE CALIFORNIA STATE PLANE COORDINATE SYSTEM, 1983, ZONE 6, BASED LOCALLY ON CONTROL STATIONS "REST" AND "RABBIT". BEARING: N 27°39'52" E

BENCHMARK: DESCRIPTION: USGS MONUMENT "REST" BENCHMARK DISK SET IN TOP OF CONCRETE MONUMENT LAMPED "REST 1972" ON DESERT LAWN DRIVE ACROSS THE DRIVE FROM DESERT LAWN CEMETERY 25.3 FT. N.E. OF THE DRIVE CENTERLINE 24.9 FT. S.W. OF THE S.W. EDGE OF THE SOUTH EASTBOUND LANES OF INTERSTATE HIGHWAY 10 ELEV. 2491.44, NGVD 29

Table for REVISIONS with columns for BY, MARK, DESCRIPTION, APPR., DATE, CITY.

PROACTIVE ENGINEERING WEST logo and contact information: 25109 JEFFERSON AVE, SUITE 200 MURRIETA, CA 92562 951-200-6840

Professional Engineer Seal for George Alan Lenfestey, No. 45920, Exp. 12/31/22, State of California.

Design and Review stamps: DESIGN BY: PEC, DRAWN BY: PEC, CHECKED BY: PEC, DATE: 04/09/21, JOB NUMBER: 06.002.000, Reviewed By: (Signature), Recommended for Approval By: (Signature), Approved By: (Signature), Date: 05/11/2021, City of Beaumont, Public Works Department Engineering Division

CITY OF BEAUMONT, CALIFORNIA STORM DRAIN IMPROVEMENT PLANS TRACT NO. 37696 TITLE SHEET, INDEX MAP, LEGEND, NOTES & QUANTITIES FOR: ARGENT MANAGEMENT

SHEET 1 OF 2 SHEETS DRAWING NUMBER: FILE NO.: 3357

Vertical text on the right edge: Date: 04/09/2021 09:49:25 AM File: C:\Users\p1\Documents\Drawings\20\37696\Storm Drain Improvements\Tr. 37696\37696-SD-SHT 01.dwg By: aeg

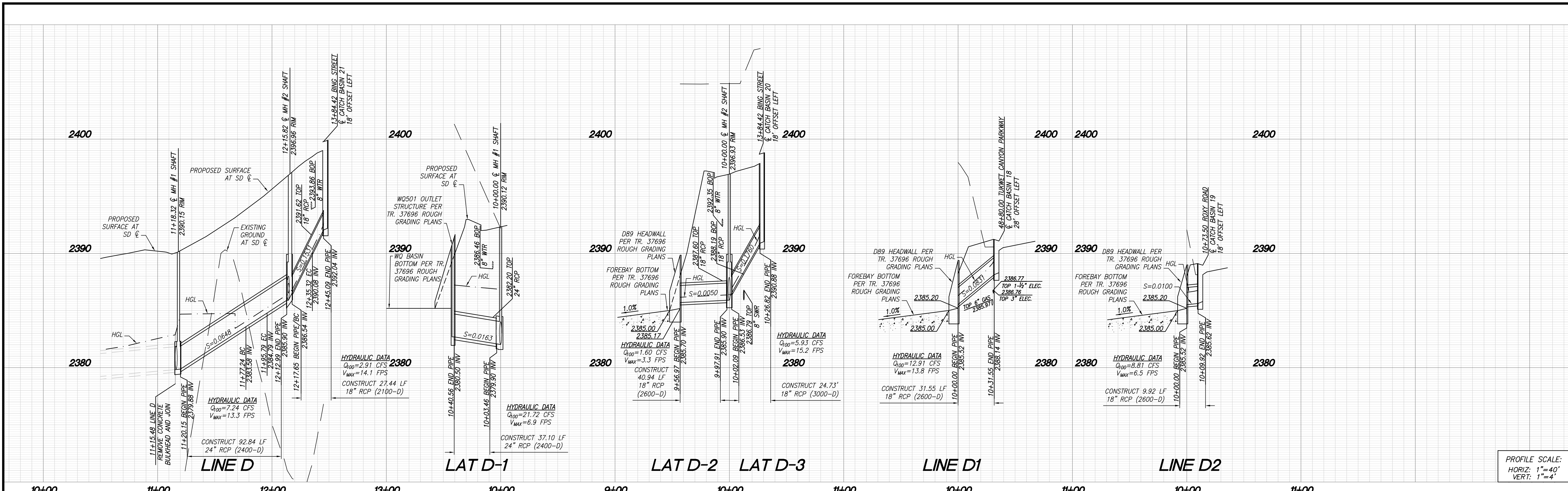

PROFILE SCALE:
HORIZ. 1"=40'
VERT. 1"=4'

10+00 11+00 12+00 13+00 10+00 9+00 10+00 11+00 10+00 11+00 10+00 11+00

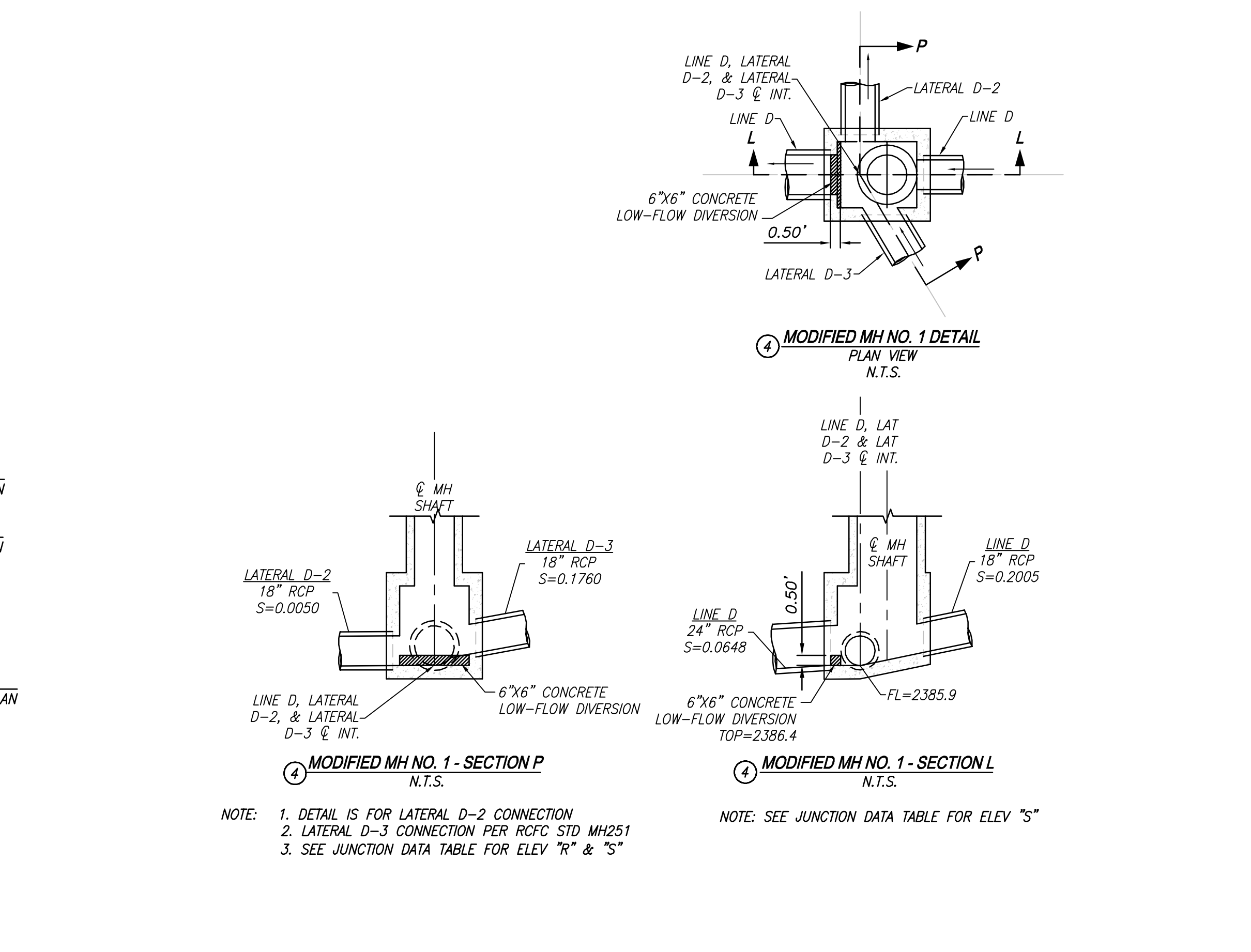
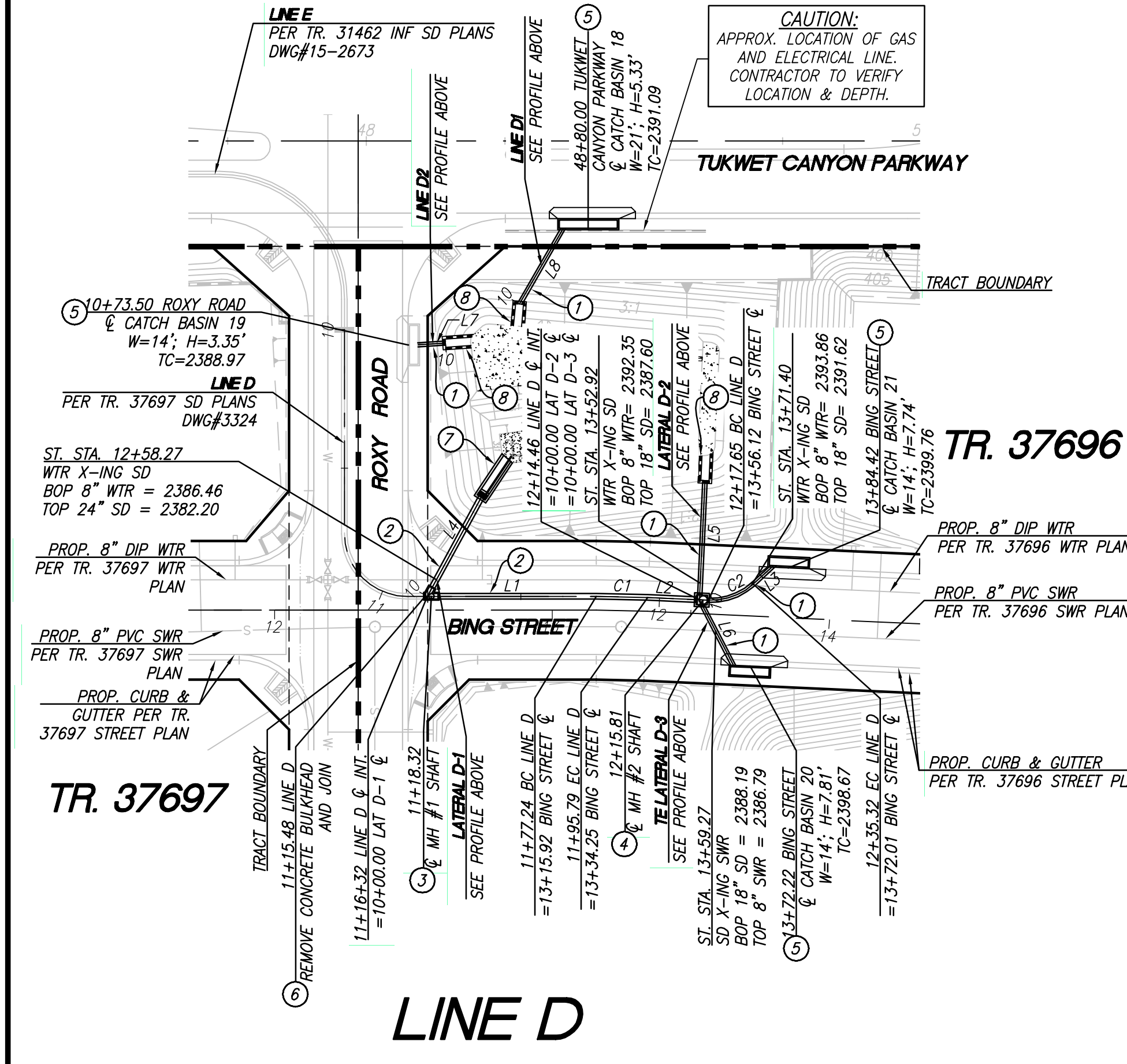

BEARING/Delta	RADIUS	LENGTH	TANGENT
C1	2'37'32"	405.00'	18.56' 9.28'
C2	45'00'00"	22.50'	17.67' 9.32'
L1	N4°55'44"W	-	57.08' -
L2	N2°18'12"W	-	17.19' -
L3	N47°18'12"W	-	9.77' -
L4	N66°19'37"W	-	37.10' -
L5	N87°41'48"E	-	40.94' -
L6	N57°41'48"E	-	24.73' -
L7	N8°41'03"W	-	9.92' -
L8	N64°55'44"W	-	31.55' -

JUNCTION ID	MAIN LINE	LATERAL	STRUCTURE TYPE	A	B	C	D ₁	D ₂	ELEV R	ELEV S
MH #1	LINE D	LINE D-1	MH NO. 4	61.4'	24"	3.8'	24"	24"	2379.90	2379.84
MH #2	LINE D	LAT D-2	MODIFIED MH NO. 1	90"	18"	---	12"	24"	2385.90	2385.90
MH #2	LINE D	LAT D-3	MODIFIED MH NO. 1	60"	18"	---	12"	24"	2386.53	2385.90

CONSTRUCTION NOTES:

- INSTALL 18" RCP (D-LOAD PER PROFILE)
- INSTALL 24" RCP (D-LOAD PER PROFILE)
- CONSTRUCT MANHOLE #4 PER R.C.F.C. & W.C.D. STD. DWG. NO. MH254.
- CONSTRUCT MODIFIED MANHOLE #1 PER R.C.F.C. & W.C.D. STD. DWG. NO. MH251. SEE DETAILS ON SHEET 2.
- CONSTRUCT CURB INLET CATCH BASIN PER COUNTY OF RIVERSIDE STD. NO. 300. NOTE: LOCAL DEPRESSION PER TR. 37696 STREET IMPROVEMENT PLANS
- REMOVE EXISTING CONCRETE BULKHEAD
- WAS01 OUTLET STRUCTURE PER TR. 37696 ROUGH GRADING PLANS
- D89 HEADWALL PER TR. 37696 ROUGH GRADING PLANS

DIAL TOLL FREE
8-1-1
AT LEAST TWO DAYS
BEFORE YOU DIG

UNDERGROUND SERVICE ALERT OF SOUTHERN CALIFORNIA

BASIS OF BEARINGS:
DESCRIPTION: THE BASIS OF COORDINATES FOR THIS MAP IS THE CALIFORNIA STATE PLANE COORDINATE SYSTEM, 1983, ZONE 6, BASED LOCALLY ON CONTROL STATIONS "REST" AND "RABBIT".
BEARING: N 27°39'52" E

BENCHMARK:
DESCRIPTION: USGS MONUMENT "REST" BENCHMARK DISK SET IN TOP OF CONCRETE MONUMENT STAMPED "REST 1972" ON DESERT LAWN DRIVE ACROSS THE DRIVE FROM DESERT LAWN CEMETERY 25.3 FT. N.E. OF THE DRIVE CENTERLINE 24.9 FT. S.W. OF THE S.W. EDGE OF THE SOUTH EASTBOUND LANES OF INTERSTATE HIGHWAY 10
ELEV. 2491.44, NGVD 29

PROACTIVE ENGINEERING WEST
2519 JEFFERSON AVE, SUITE 200
MURRIETA, CA 92562
951-200-0860

GEORGE ALAN LENESEY
R.C.E. 45920 EXP. 12-31-2022

04/09/21

DESIGN BY: PEC
DRAWN BY: PEC
CHECKED BY: PEC
SCALE: AS NOTED
DATE: 04/09/21
JOB NUMBER: 06.002.000

Reviewed By: *[Signature]* STAFF ENGINEER Date: 4/30/2021
Recommended for Approval By: *[Signature]* Date: 4/30/2021
Approved By: *[Signature]* CITY ENGINEER Date: 05/11/2021

City of Beaumont, Public Works Department
Engineering Division

CITY OF BEAUMONT, CALIFORNIA
STORM DRAIN IMPROVEMENT PLANS
TRACT NO. 37696

LINE D, LINE D1, LINE D2, LATERAL D-1,
LATERAL D-2, & LATERAL D-3

ARGENT MANAGEMENT

SHEET
2
OF 2 SHEETS
DRAWING NUMBER:
FILE NO.: 3357