



City of Beaumont

550 E. 6th Street
Beaumont, CA 92223
(951) 769-8520
www.ci.beaumont.ca.us

Case No. PW2020-0559
Receipt No. R01116935
Fee \$ \$3,000.00/ \$484.14
Date Paid 10/5/2020

BOND EXONERATION APPLICATION

Bond Type: Performance Maintenance Final Monument Inspection Other: Laborers and Materialmen

- Contact's Name Jan Harriman Phone (949) 375-4533
- Contact's Address 24 Cormorant Circle, Newport Beach, CA
City/State/Zip 92660
- Contact's E-mail jfmck@aol.com
- Developer Name Beaumont Sundance, LLC Phone (949) 375-4533
(If corporation or partnership application must include names of principal officers or partners) SEE ATTACHED
- Developer Address 1059 TIERRA Del Rey, SUITE L, CHULA VISTA, CA
City/St/Zip 91910
- Description of Bonds (including Bond Number, Tract Map/Application number, Lot number, and description of improvements covered):
Bond # 441590 - Channel Improvements
Parcel map 35789 # 936,516.07

6. **CERTIFICATION OF ACCURACY AND COMPLETENESS:** I hereby certify that to the best of my knowledge the information in this application and all attached answers and exhibits are true, complete, and correct.

X JAN HARRIMAN JH 10-05-2020
Print Name and Sign - Contact/Applicant Date

7. Contractor shall indemnify, defend, and hold harmless the City and its officers, officials, employees and volunteers from and against any and all liability, loss, damage, expense, costs (including without limitation costs and fees of litigation) of every nature arising out of or in connection with contractor's performance of work hereunder or its failure to comply with any of its obligations for which this Bond exoneration is requested, except for such loss or damage which was caused by the active negligence of the City.

X JAN HARRIMAN JH 10-05-2020
Print Name and Sign - Contact/Applicant Date

8. Developer/Contractor has completed all the following items prior to requesting release or has included them in the application.

- Remove and replace concrete and AC as needed where lifting.
- Provide AC crack fill as needed. Crack fill/seal shall be hot asphaltic emulsion.
- Provide Type II slurry coat for all road surfaces.
- Restore/Verify pavement striping/markings.
- Restore/Verify blue dots and signage as needed.
- Clean and camera sewer. Provide report and video copy of camera survey.
- Provide all final geotechnical reports.
- Provide Engineers' certification for line and grade within Right-of-Way.
- Provide Landscape Architects Certification as required.

X JAW HARRIMAN

JAW

10-05-2020

Print Name and Sign – Contact/Applicant

Date

BOND NO. 4415890
PREMIUM: \$17,048.00
THE TERM OF THIS BOND IS TWO (2) YEARS

PERFORMANCE BOND

WHEREAS, the City Council of the City of Beaumont, State of California, and BEAUMONT SUNDANCE, LLC (hereinafter designated as "Principal") have entered into an agreement whereby Principal agrees to install and complete certain designated public improvements, which agreement, dated _____, 20____, and identified as project HIGHLAND SPRINGS STORM DRAIN CHANNEL IMPROVEMENTS (PARCEL MAP NO. 35789), is hereby referred to and made a part hereof; and

WHEREAS, Principal is required under the terms of the said agreement to furnish a bond for the faithful performance of said agreement.

NOW, THEREFORE, we, the Principal and SURETEC INSURANCE COMPANY, as Surety, are held and firmly bound unto the City of Beaumont (hereinafter called "City"), in the penal sum of NINE HUNDRED THIRTY SIX THOUSAND FIVE HUNDRED SIXTEEN AND 07/100 dollars (\$ 936,516.07) lawful money of the United States, for the payment of which sum well and truly to be made, we bind ourselves, our heirs, successors, executors and administrators, jointly and severally, firmly by these presents.

The condition of this obligation is such that if the Principal, his or its heirs, executors, administrators, successors or assigns, shall in all things stand to and abide by, and well and truly keep and perform the covenants, conditions and provisions in the said agreement and any alteration thereof made as therein provided, on his or their part to be kept and performed at the time and in the manner therein specified, and in all respects according to their true intent and meaning, and shall indemnify and save harmless the City, its officers, agents and employees as therein stipulated, then this obligation shall become null and void; otherwise it shall be and remain in full force and effect.

As part of the obligation secured hereby and in addition to the face amount specified therefor, there shall be included costs and reasonable expenses and fees, including reasonable attorney's fees, incurred by the City in successfully enforcing such obligation, all to be taxed as costs and included in any judgment therein rendered.

The Surety hereby stipulates and agrees that no change, extension of time, alteration or addition to the terms of the agreement or to the work to be performed thereunder or the specifications accompanying the same shall in any way affect its obligations on this bond, and it does hereby waive notice of any such change, extension of time, alteration or addition to the terms of the agreement or to the work or to the specifications.

IN WITNESS WHEREOF, this instrument has been duly executed by the Principal and Surety above named, on NOVEMBER 13, 2017.

PRINCIPAL:
BEAUMONT SUNDANCE, LLC
By 
Title SOLOMON LEVY, MANAGING MEMBER

SURETY:
SURETEC INSURANCE COMPANY
By 
Title MARK D. IATAROLA, ATTORNEY-IN-FACT



CALIFORNIA ALL-PURPOSE ACKNOWLEDGMENT

CIVIL CODE § 1189

A notary public or other officer completing this certificate verifies only the identity of the individual who signed the document to which this certificate is attached, and not the truthfulness, accuracy, or validity of that document.

State of California)

County of SAN DIEGO)

On 11/13/2017 before me, SANDRA FIGUEROA, NOTARY PUBLIC

Date

Here Insert Name and Title of the Officer

personally appeared MARK D. IATAROLA

Name(s) of Signer(s)

who proved to me on the basis of satisfactory evidence to be the person(s) whose name(s) is/are subscribed to the within instrument and acknowledged to me that he/she/they executed the same in his/her/their authorized capacity(ies), and that by his/her/their signature(s) on the instrument the person(s), or the entity upon behalf of which the person(s) acted, executed the instrument.

I certify under PENALTY OF PERJURY under the laws of the State of California that the foregoing paragraph is true and correct.

WITNESS my hand and official seal.



Signature *Sandra Figueroa*
Signature of Notary Public

Place Notary Seal Above

OPTIONAL

Though this section is optional, completing this information can deter alteration of the document or fraudulent reattachment of this form to an unintended document.

Description of Attached Document

Title or Type of Document: _____ Document Date: _____

Number of Pages: _____ Signer(s) Other Than Named Above: _____

Capacity(ies) Claimed by Signer(s)

Signer's Name: MARK D. IATAROLA

Corporate Officer — Title(s): _____

Partner — Limited General

Individual Attorney in Fact

Trustee Guardian or Conservator

Other: _____

Signer Is Representing: _____

Signer's Name: _____

Corporate Officer — Title(s): _____

Partner — Limited General

Individual Attorney in Fact

Trustee Guardian or Conservator

Other: _____

Signer Is Representing: _____

SureTec Insurance Company

LIMITED POWER OF ATTORNEY

Know All Men by These Presents, That SURETEC INSURANCE COMPANY (the "Company"), a corporation duly organized and existing under the laws of the State of Texas, and having its principal office in Houston, Harris County, Texas, does by these presents make, constitute and appoint

Helen Maloney, Mark D. Iatarola, John G. Maloney, Sandra Figueroa

its true and lawful Attorney-in-fact, with full power and authority hereby conferred in its name, place and stead, to execute, acknowledge and deliver any and all bonds, recognizances, undertakings or other instruments or contracts of suretyship to include waivers to the conditions of contracts and consents of surety for, providing the bond penalty does not exceed

Five Million and 00/100 Dollars (\$5,000,000.00)

and to bind the Company thereby as fully and to the same extent as if such bond were signed by the President, sealed with the corporate seal of the Company and duly attested by its Secretary, hereby ratifying and confirming all that the said Attorney-in-Fact may do in the premises. Said appointment shall continue in force until 12/31/2019 and is made under and by authority of the following resolutions of the Board of Directors of the SureTec Insurance Company:

Be it Resolved, that the President, any Vice-President, any Assistant Vice-President, any Secretary or any Assistant Secretary shall be and is hereby vested with full power and authority to appoint any one or more suitable persons as Attorney(s)-in-Fact to represent and act for and on behalf of the Company subject to the following provisions:

Attorney-in-Fact may be given full power and authority for and in the name of and of behalf of the Company, to execute, acknowledge and deliver, any and all bonds, recognizances, contracts, agreements or indemnity and other conditional or obligatory undertakings and any and all notices and documents canceling or terminating the Company's liability thereunder, and any such instruments so executed by any such Attorney-in-Fact shall be binding upon the Company as if signed by the President and sealed and effected by the Corporate Secretary.

Be it Resolved, that the signature of any authorized officer and seal of the Company heretofore or hereafter affixed to any power of attorney or any certificate relating thereto by facsimile, and any power of attorney or certificate bearing facsimile signature or facsimile seal shall be valid and binding upon the Company with respect to any bond or undertaking to which it is attached. (Adopted at a meeting held on 20th of April, 1999.)

In Witness Whereof, SURETEC INSURANCE COMPANY has caused these presents to be signed by its President, and its corporate seal to be hereto affixed this 16th day of January, A.D. 2017.

SURETEC INSURANCE COMPANY

By: 
John Knox Jr., President

State of Texas
County of Harris

ss:



On this 16th day of January, A.D. 2017 before me personally came John Knox Jr., to me known, who, being by me duly sworn, did depose and say, that he resides in Houston, Texas, that he is President of SURETEC INSURANCE COMPANY, the company described in and which executed the above instrument; that he knows the seal of said Company; that the seal affixed to said instrument is such corporate seal; that it was so affixed by order of the Board of Directors of said Company; and that he signed his name thereto by like order.

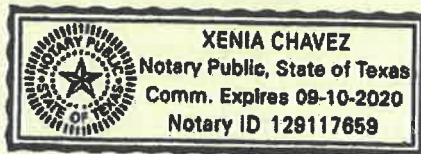

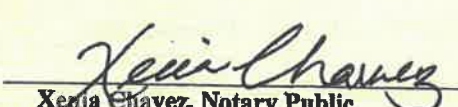
Xenia Chavez, Notary Public
My commission expires September 10, 2020

I, M. Brent Beaty, Assistant Secretary of SURETEC INSURANCE COMPANY, do hereby certify that the above and foregoing is a true and correct copy of a Power of Attorney, executed by said Company, which is still in full force and effect; and furthermore, the resolutions of the Board of Directors, set out in the Power of Attorney are in full force and effect.

Given under my hand and the seal of said Company at Houston, Texas this 13TH day of NOVEMBER 2017, A.D.

M. Brent Beaty, Assistant Secretary

Any instrument issued in excess of the penalty stated above is totally void and without any validity.
For verification of the authority of this power you may call (713) 812-0800 any business day between 8:00 am and 5:00 pm CST.

CALIFORNIA ALL-PURPOSE CERTIFICATE OF ACKNOWLEDGMENT

State of California

County of San Diego

A notary public or other officer completing this certificate verifies only the identity of the individual who signed the document to which this certificate is attached, and not the truthfulness, accuracy, or validity of that document.

On NOVEMBER 17, 2017 before me, Joseph Conway, Notary Public,
(here insert name and title of the officer)

personally appeared SOLOMON LEVY

who proved to me on the basis of satisfactory evidence to be the person(s) whose name(s) (s) is/are subscribed to the within instrument and acknowledged to me that (s) he/she/they executed the same in (s) his/het/their authorized capacity(ies), and that by (s) his/het/their signature(s) on the instrument the person(s), or the entity upon behalf of which the person(s) acted, executed the instrument.

I certify under PENALTY OF PERJURY under the laws of the State of California that the foregoing paragraph is true and correct.

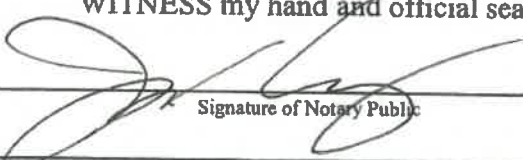
WITNESS my hand and official seal.

Signature of Notary Public



(Seal)

ADDITIONAL OPTIONAL INFORMATION

DESCRIPTION OF THE ATTACHED DOCUMENT

PERFORMANCE BOND
(Title or description of attached document)

(Title or description of attached document continued)

Number of Pages _____ Document Date ____ / ____ / ____

(Additional information)

CAPACITY CLAIMED BY THE SIGNER

Individual (s)
 Corporate Officer

(Title)

Partner(s)
 Attorney-in-Fact
 Trustee(s)
 Other _____

INSTRUCTIONS FOR COMPLETING THIS FORM

Any acknowledgment completed in California must contain verbiage exactly as appears above in the notary section or a separate acknowledgment form must be properly completed and attached to that document. The only exception is if a document is to be recorded outside of California. In such instances, any alternative acknowledgment verbiage as may be printed on such a document so long as the verbiage does not require the notary to do something that is illegal for a notary in California (i.e. certifying the authorized capacity of the signer). Please check the document carefully for proper notarial wording and attach this form if required.

- State and County information must be the State and County where the document signer(s) personally appeared before the notary public for acknowledgment.
- Date of notarization must be the date that the signer(s) personally appeared which must also be the same date the acknowledgment is completed.
- The notary public must print his or her name as it appears within his or her commission followed by a comma and then your title (notary public).
- Print the name(s) of document signer(s) who personally appear at the time of notarization.
- Indicate the correct singular or plural forms by crossing off incorrect forms (i.e. ~~he~~/she/they-, is /are) or circling the correct forms. Failure to correctly indicate this information may lead to rejection of document recording.
- The notary seal impression must be clear and photographically reproducible. Impression must not cover text or lines. If seal impression smudges, re-seal if a sufficient area permits, otherwise complete a different acknowledgment form.
- Signature of the notary public must match the signature on file with the office of the county clerk.
 - ❖ Additional information is not required but could help to ensure this acknowledgment is not misused or attached to a different document.
 - ❖ Indicate title or type of attached document, number of pages and date.
 - ❖ Indicate the capacity claimed by the signer. If the claimed capacity is a corporate officer, indicate the title (i.e. CEO, CFO, Secretary).
- Securely attach this document to the signed document

SureTec Insurance Company

RIDER TO BE ATTACHED TO AND FORM A PART OF BOND NO. 4415890
PERFORMANCE BOND

Wherein BEAUMONT SUNDANCE, LLC is named as Principal and SureTec Insurance Company, as Surety in favor of RIVERSIDE COUNTY FLOOD CONTROL AND WATER CONSERVATION DISTRICT as Obligees, in the amount of \$ 936,516.07 effective NOVEMBER 13, 2017 for HIGHLAND SPRINGS STORM DRAIN CHANNEL IMPROVEMENTS.

WHEREAS, when this bond was executed CITY OF BEAUMONT was named as Obligees, and

WHEREAS, it is now desired that certain other parties be added as Obligees.

NOW, THEREFORE, it is hereby understood and agreed that the following shall be considered as additional Obligees under this bond:

RIVERSIDE COUNTY FLOOD CONTROL AND WATER CONSERVATION DISTRICT

The foregoing, however, is subject to the following further provisions:

- (1) The Surety shall not be liable under this bond to the Obligees, or any of them, unless the said Obligees, or any of them, shall make payment to the Principal strictly in accordance with the term of said contract as to payments, and shall promptly perform all other obligations to be performed to by the first named obligee under said contract at the time and in the manner therein set forth.
- (2) The Principal and the Surety shall not be liable to any one or to all of the Obligees in the aggregate in excess of the penal sum of the bond, to wit: \$ 936,516.07 .

Signed, and sealed this 13TH day of NOVEMBER, 2017 .

BEAUMONT SUNDANCE, LLC
(Principal)

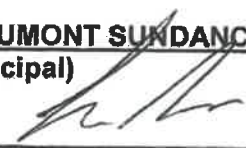
By: 
SOLOMON LEVY, MANAGING MEMBER
SureTec Insurance Company

By: 
MARK D. IATAROLA, Attorney-in-Fact

CALIFORNIA ALL-PURPOSE ACKNOWLEDGMENT

CIVIL CODE § 1189

A notary public or other officer completing this certificate verifies only the identity of the individual who signed the document to which this certificate is attached, and not the truthfulness, accuracy, or validity of that document.

State of California)
County of SAN DIEGO)

On 11/13/2017 before me, SANDRA FIGUEROA, NOTARY PUBLIC,
Date Here Insert Name and Title of the Officer
personally appeared MARK D. IATAROLA
Name(s) of Signer(s)

who proved to me on the basis of satisfactory evidence to be the person(s) whose name(s) is/are subscribed to the within instrument and acknowledged to me that he/she/they executed the same in his/her/their authorized capacity(ies), and that by his/her/their signature(s) on the instrument the person(s), or the entity upon behalf of which the person(s) acted, executed the instrument.

I certify under PENALTY OF PERJURY under the laws of the State of California that the foregoing paragraph is true and correct.

WITNESS my hand and official seal.

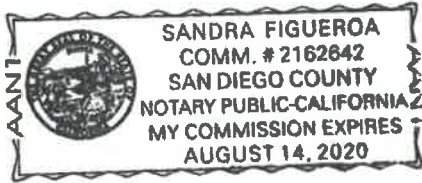

Signature *Sandra Figueroa*
Signature of Notary Public

Place Notary Seal Above

OPTIONAL

Though this section is optional, completing this information can deter alteration of the document or fraudulent reattachment of this form to an unintended document.

Description of Attached Document

Title or Type of Document: _____ Document Date: _____
Number of Pages: _____ Signer(s) Other Than Named Above: _____

Capacity(ies) Claimed by Signer(s)

Signer's Name: MARK D. IATAROLA
 Corporate Officer — Title(s): _____
 Partner — Limited General
 Individual Attorney in Fact
 Trustee Guardian or Conservator
 Other: _____
Signer Is Representing: _____

Signer's Name: _____
 Corporate Officer — Title(s): _____
 Partner — Limited General
 Individual Attorney in Fact
 Trustee Guardian or Conservator
 Other: _____
Signer Is Representing: _____

SureTec Insurance Company

LIMITED POWER OF ATTORNEY

Know All Men by These Presents, That SURETEC INSURANCE COMPANY (the "Company"), a corporation duly organized and existing under the laws of the State of Texas, and having its principal office in Houston, Harris County, Texas, does by these presents make, constitute and appoint

Helen Maloney, Mark D. Iatarola, John G. Maloney, Sandra Figueroa

its true and lawful Attorney-in-fact, with full power and authority hereby conferred in its name, place and stead, to execute, acknowledge and deliver any and all bonds, recognizances, undertakings or other instruments or contracts of suretyship to include waivers to the conditions of contracts and consents of surety for, providing the bond penalty does not exceed

Five Million and 00/100 Dollars (\$5,000,000.00)

and to bind the Company thereby as fully and to the same extent as if such bond were signed by the President, sealed with the corporate seal of the Company and duly attested by its Secretary, hereby ratifying and confirming all that the said Attorney-in-Fact may do in the premises. Said appointment shall continue in force until 12/31/2019 and is made under and by authority of the following resolutions of the Board of Directors of the SureTec Insurance Company:

Be it Resolved, that the President, any Vice-President, any Assistant Vice-President, any Secretary or any Assistant Secretary shall be and is hereby vested with full power and authority to appoint any one or more suitable persons as Attorney(s)-in-Fact to represent and act for and on behalf of the Company subject to the following provisions:

Attorney-in-Fact may be given full power and authority for and in the name of and of behalf of the Company, to execute, acknowledge and deliver, any and all bonds, recognizances, contracts, agreements or indemnity and other conditional or obligatory undertakings and any and all notices and documents canceling or terminating the Company's liability thereunder, and any such instruments so executed by any such Attorney-in-Fact shall be binding upon the Company as if signed by the President and sealed and effected by the Corporate Secretary.

Be it Resolved, that the signature of any authorized officer and seal of the Company heretofore or hereafter affixed to any power of attorney or any certificate relating thereto by facsimile, and any power of attorney or certificate bearing facsimile signature or facsimile seal shall be valid and binding upon the Company with respect to any bond or undertaking to which it is attached. (Adopted at a meeting held on 20th of April, 1999.)

In Witness Whereof, SURETEC INSURANCE COMPANY has caused these presents to be signed by its President, and its corporate seal to be hereto affixed this 16th day of January, A.D. 2017.

SURETEC INSURANCE COMPANY

By: [Signature]
John Knox Jr., President



State of Texas SS:
County of Harris

On this 16th day of January, A.D. 2017 before me personally came John Knox Jr., to me known, who, being by me duly sworn, did depose and say, that he resides in Houston, Texas, that he is President of SURETEC INSURANCE COMPANY, the company described in and which executed the above instrument; that he knows the seal of said Company; that the seal affixed to said instrument is such corporate seal; that it was so affixed by order of the Board of Directors of said Company; and that he signed his name thereto by like order.

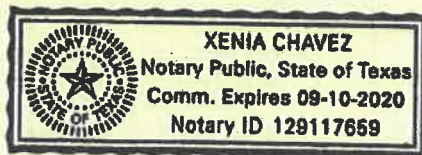

[Signature]
Xenia Chavez, Notary Public
My commission expires September 10, 2020

I, M. Brent Beaty, Assistant Secretary of SURETEC INSURANCE COMPANY, do hereby certify that the above and foregoing is a true and correct copy of a Power of Attorney, executed by said Company, which is still in full force and effect; and furthermore, the resolutions of the Board of Directors, set out in the Power of Attorney are in full force and effect.

Given under my hand and the seal of said Company at Houston, Texas this 13TH day of NOVEMBER 2017, A.D.

[Signature]
M. Brent Beaty, Assistant Secretary

Any Instrument issued in excess of the penalty stated above is totally void and without any validity.
For verification of the authority of this power you may call (713) 812-0800 any business day between 8:00 am and 5:00 pm CST.

CALIFORNIA ALL-PURPOSE CERTIFICATE OF ACKNOWLEDGMENT

State of California

County of San Diego

A notary public or other officer completing this certificate verifies only the identity of the individual who signed the document to which this certificate is attached, and not the truthfulness, accuracy, or validity of that document.

On NOVEMBER 17, 2017 before me, Joseph Conway, Notary Public,
(here insert name and title of the officer)

personally appeared SALOMON LEVY

who proved to me on the basis of satisfactory evidence to be the person~~(s)~~ whose name~~(s)~~ is/are subscribed to the within instrument and acknowledged to me that he~~/she/they~~ executed the same in his~~/her/their~~ authorized capacity~~(ies)~~, and that by his/her/their signature~~(s)~~ on the instrument the person~~(s)~~, or the entity upon behalf of which the person~~(s)~~ acted, executed the instrument.

I certify under PENALTY OF PERJURY under the laws of the State of California that the foregoing paragraph is true and correct.

WITNESS my hand and official seal.

[Signature]
Signature of Notary Public



(Seal)

ADDITIONAL OPTIONAL INFORMATION

DESCRIPTION OF THE ATTACHED DOCUMENT

SURETEC BOND RIDER
(Title or description of attached document)

(Title or description of attached document continued)

Number of Pages _____ Document Date ____ / ____ / ____

(Additional information)

CAPACITY CLAIMED BY THE SIGNER

Individual (s)
 Corporate Officer

(Title)

Partner(s)
 Attorney-in-Fact
 Trustee(s)
 Other _____

INSTRUCTIONS FOR COMPLETING THIS FORM

Any acknowledgment completed in California must contain verbiage exactly as appears above in the notary section or a separate acknowledgment form must be properly completed and attached to that document. The only exception is if a document is to be recorded outside of California. In such instances, any alternative acknowledgment verbiage as may be printed on such a document so long as the verbiage does not require the notary to do something that is illegal for a notary in California (i.e. certifying the authorized capacity of the signer). Please check the document carefully for proper notarial wording and attach this form if required.

- State and County information must be the State and County where the document signer(s) personally appeared before the notary public for acknowledgment.
- Date of notarization must be the date that the signer(s) personally appeared which must also be the same date the acknowledgment is completed.
- The notary public must print his or her name as it appears within his or her commission followed by a comma and then your title (notary public).
- Print the name(s) of document signer(s) who personally appear at the time of notarization.
- Indicate the correct singular or plural forms by crossing off incorrect forms (i.e. he/she/they, is /are) or circling the correct forms. Failure to correctly indicate this information may lead to rejection of document recording.
- The notary seal impression must be clear and photographically reproducible. Impression must not cover text or lines. If seal impression smudges, re-seal if a sufficient area permits, otherwise complete a different acknowledgment form.
- Signature of the notary public must match the signature on file with the office of the county clerk.
 - ❖ Additional information is not required but could help to ensure this acknowledgment is not misused or attached to a different document.
 - ❖ Indicate title or type of attached document, number of pages and date.
 - ❖ Indicate the capacity claimed by the signer. If the claimed capacity is a corporate officer, indicate the title (i.e. CEO, CFO, Secretary).
- Securely attach this document to the signed document

BOND FOR SECURITY OF LABORERS AND MATERIALMEN

WHEREAS, the City Council of the City of Beaumont, State of California, and BEAUMONT SUNDANCE, LLC (hereafter designated as "the Principal") have entered into an agreement whereby the Principal agrees to install and complete certain designed public improvements, which agreement, dated _____, 20____, and identified as project HIGHLAND SPRINGS STORM DRAIN CHANNEL IMPROVEMENTS (PARCEL MAP NO. 35789), is hereby referred to and made a part hereof; and

WHEREAS, under the terms of the said agreement, the Principal is required before entering upon the performance of the work, to file a good and sufficient payment bond with the City of Beaumont to secure the claims to which reference is made in Title 15 (commencing with Section 3082) of Part 4 of Division 3 of the Civil Code of the State of California.

NOW, THEREFORE, the Principal and the undersigned as corporate surety, are held firmly bound unto the City of Beaumont and all contractors, subcontractors, laborers, materialmen, and other persons employed in the performance of the said agreement and referred to in Title 15 (commencing with Section 3082) of Part 4 of Division 3 of the Civil Code in the sum of NINE HUNDRED THIRTY SIX THOUSAND FIVE HUNDRED SIXTEEN AND 07/100 dollars (\$ 936,516.07), for materials furnished or labor thereon of any kind, or for amounts due under the Unemployment Insurance Act with respect to this work or labor, that the Surety will pay the same in an amount not exceeding the amount hereinabove set forth, and also in case suit is brought upon this bond, will pay, in addition to the face amount thereof, costs and reasonable expenses and fees, including reasonable attorney's fees, incurred by the City in successfully enforcing this obligation, to be awarded and fixed by the court, and to be taxed as costs and to be included in the judgment therein rendered.

It is hereby expressly stipulated and agreed that this bond shall inure to the benefit of any and all persons, companies, and corporations entitled to file claims under Title 15 (commencing with Section 3082) of Part 4 of Division 3 of the Civil Code, so as to give a right of action to them or their assigns in any suit brought upon this bond.

Should the condition of this bond be fully performed, then this obligation shall become null and void, otherwise it shall be and remain in full force and effect.

The Surety hereby stipulates and agrees that no change, extension of time, alteration, or addition to the terms of the agreement or the specifications accompanying the same shall in any manner affect its obligations on this bond, and it does hereby waive notice of any such change, extension, alteration, or addition.

IN WITNESS WHEREOF, this instrument has been duly executed by the Principal and Surety above named, on NOVEMBER 13, 20 17.

PRINCIPAL:

SUNDANCE BEAUMONT, LLC

By 

Title SOLOMON LEVY, MANAGING MEMBER

SURETY:

SURETEC INSURANCE COMPANY

By 

Title MARK D. IATAROLA, ATTORNEY-IN-FACT

CALIFORNIA ALL-PURPOSE ACKNOWLEDGMENT

CIVIL CODE § 1189

A notary public or other officer completing this certificate verifies only the identity of the individual who signed the document to which this certificate is attached, and not the truthfulness, accuracy, or validity of that document.

State of California)
County of SAN DIEGO)

On 11/13/2017 before me, SANDRA FIGUEROA, NOTARY PUBLIC,
Date Here Insert Name and Title of the Officer
personally appeared MARK D. IATAROLA
Name(s) of Signer(s)

who proved to me on the basis of satisfactory evidence to be the person(s) whose name(s) is/are subscribed to the within instrument and acknowledged to me that he/she/they executed the same in his/her/their authorized capacity(ies), and that by his/her/their signature(s) on the instrument the person(s), or the entity upon behalf of which the person(s) acted, executed the instrument.

I certify under PENALTY OF PERJURY under the laws of the State of California that the foregoing paragraph is true and correct.

WITNESS my hand and official seal.



Signature *Sandra Figueroa*
Signature of Notary Public

Place Notary Seal Above

OPTIONAL

Though this section is optional, completing this information can deter alteration of the document or fraudulent reattachment of this form to an unintended document.

Description of Attached Document

Title or Type of Document: _____ Document Date: _____
Number of Pages: _____ Signer(s) Other Than Named Above: _____

Capacity(ies) Claimed by Signer(s)

Signer's Name: MARK D. IATAROLA
 Corporate Officer — Title(s): _____
 Partner — Limited General
 Individual Attorney in Fact
 Trustee Guardian or Conservator
 Other: _____
Signer Is Representing: _____

Signer's Name: _____
 Corporate Officer — Title(s): _____
 Partner — Limited General
 Individual Attorney in Fact
 Trustee Guardian or Conservator
 Other: _____
Signer Is Representing: _____

SureTec Insurance Company

LIMITED POWER OF ATTORNEY

Know All Men by These Presents, That SURETEC INSURANCE COMPANY (the "Company"), a corporation duly organized and existing under the laws of the State of Texas, and having its principal office in Houston, Harris County, Texas, does by these presents make, constitute and appoint

Helen Maloney, Mark D. Iatarola, John G. Maloney, Sandra Figueroa

its true and lawful Attorney-in-fact, with full power and authority hereby conferred in its name, place and stead, to execute, acknowledge and deliver any and all bonds, recognizances, undertakings or other instruments or contracts of suretyship to include waivers to the conditions of contracts and consents of surety for, providing the bond penalty does not exceed

Five Million and 00/100 Dollars (\$5,000,000.00)

and to bind the Company thereby as fully and to the same extent as if such bond were signed by the President, sealed with the corporate seal of the Company and duly attested by its Secretary, hereby ratifying and confirming all that the said Attorney-in-Fact may do in the premises. Said appointment shall continue in force until 12/31/2018 and is made under and by authority of the following resolutions of the Board of Directors of the SureTec Insurance Company:

Be it Resolved, that the President, any Vice-President, any Assistant Vice-President, any Secretary or any Assistant Secretary shall be and is hereby vested with full power and authority to appoint any one or more suitable persons as Attorney(s)-in-Fact to represent and act for and on behalf of the Company subject to the following provisions:

Attorney-in-Fact may be given full power and authority for and in the name of and of behalf of the Company, to execute, acknowledge and deliver, any and all bonds, recognizances, contracts, agreements or indemnity and other conditional or obligatory undertakings and any and all notices and documents canceling or terminating the Company's liability thereunder, and any such instruments so executed by any such Attorney-in-Fact shall be binding upon the Company as if signed by the President and sealed and effected by the Corporate Secretary.

Be it Resolved, that the signature of any authorized officer and seal of the Company heretofore or hereafter affixed to any power of attorney or any certificate relating thereto by facsimile, and any power of attorney or certificate bearing facsimile signature or facsimile seal shall be valid and binding upon the Company with respect to any bond or undertaking to which it is attached. (Adopted at a meeting held on 20th of April, 1999.)

In Witness Whereof, SURETEC INSURANCE COMPANY has caused these presents to be signed by its President, and its corporate seal to be hereto affixed this 16th day of January, A.D. 2017.

SURETEC INSURANCE COMPANY

By: [Signature]
John Knox Jr., President



State of Texas ss:
County of Harris

On this 16th day of January, A.D. 2017 before me personally came John Knox Jr., to me known, who, being by me duly sworn, did depose and say, that he resides in Houston, Texas, that he is President of SURETEC INSURANCE COMPANY, the company described in and which executed the above instrument; that he knows the seal of said Company; that the seal affixed to said instrument is such corporate seal; that it was so affixed by order of the Board of Directors of said Company; and that he signed his name thereto by like order.

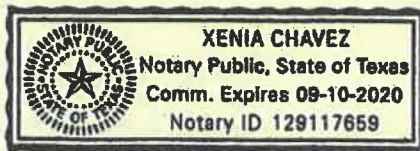

[Signature]
Xenia Chavez, Notary Public
My commission expires September 10, 2020

I, M. Brent Beaty, Assistant Secretary of SURETEC INSURANCE COMPANY, do hereby certify that the above and foregoing is a true and correct copy of a Power of Attorney, executed by said Company, which is still in full force and effect; and furthermore, the resolutions of the Board of Directors, set out in the Power of Attorney are in full force and effect.

Given under my hand and the seal of said Company at Houston, Texas this 13TH day of NOVEMBER 2017, A.D.

[Signature]
M. Brent Beaty, Assistant Secretary

Any instrument issued in excess of the penalty stated above is totally void and without any validity.
For verification of the authority of this power you may call (713) 812-0800 any business day between 8:00 am and 5:00 pm CST.

CALIFORNIA ALL-PURPOSE CERTIFICATE OF ACKNOWLEDGMENT

State of California

County of San Diego

A notary public or other officer completing this certificate verifies only the identity of the individual who signed the document to which this certificate is attached, and not the truthfulness, accuracy, or validity of that document.

On NOVEMBER 17, 2017 before me, Joseph Conway, Notary Public,
(here insert name and title of the officer)

personally appeared SALOMON LEVY

who proved to me on the basis of satisfactory evidence to be the person(s) whose name(s) is subscribed to the within instrument and acknowledged to me that he executed the same in his authorized capacity(ies), and that by his signature(s) on the instrument the person(s), or the entity upon behalf of which the person(s) acted, executed the instrument.

I certify under PENALTY OF PERJURY under the laws of the State of California that the foregoing paragraph is true and correct.

WITNESS my hand and official seal.

[Signature]
Signature of Notary Public



(Seal)

ADDITIONAL OPTIONAL INFORMATION

DESCRIPTION OF THE ATTACHED DOCUMENT

LABORERS/MATERIALMEN SECURITY BOND
(Title or description of attached document)

(Title or description of attached document continued)

Number of Pages _____ Document Date ____ / ____ / ____

(Additional information)

CAPACITY CLAIMED BY THE SIGNER

Individual (s)

Corporate Officer

(Title)

Partner(s)

Attorney-in-Fact

Trustee(s)

Other _____

- INSTRUCTIONS FOR COMPLETING THIS FORM**
- Any acknowledgment completed in California must contain verbiage exactly as appears above in the notary section or a separate acknowledgment form must be properly completed and attached to that document. The only exception is if a document is to be recorded outside of California. In such instances, any alternative acknowledgment verbiage as may be printed on such a document so long as the verbiage does not require the notary to do something that is illegal for a notary in California (i.e. certifying the authorized capacity of the signer). Please check the document carefully for proper notarial wording and attach this form if required.*
- State and County information must be the State and County where the document signer(s) personally appeared before the notary public for acknowledgment.
 - Date of notarization must be the date that the signer(s) personally appeared which must also be the same date the acknowledgment is completed.
 - The notary public must print his or her name as it appears within his or her commission followed by a comma and then your title (notary public).
 - Print the name(s) of document signer(s) who personally appear at the time of notarization.
 - Indicate the correct singular or plural forms by crossing off incorrect forms (i.e. ~~he~~/she/~~they~~, is /~~are~~) or circling the correct forms. Failure to correctly indicate this information may lead to rejection of document recording.
 - The notary seal impression must be clear and photographically reproducible. Impression must not cover text or lines. If seal impression smudges, re-seal if a sufficient area permits, otherwise complete a different acknowledgment form.
 - Signature of the notary public must match the signature on file with the office of the county clerk.
 - ❖ Additional information is not required but could help to ensure this acknowledgment is not misused or attached to a different document.
 - ❖ Indicate title or type of attached document, number of pages and date.
 - ❖ Indicate the capacity claimed by the signer. If the claimed capacity is a corporate officer, indicate the title (i.e. CEO, CFO, Secretary).
 - Securely attach this document to the signed document

SureTec Insurance Company

RIDER TO BE ATTACHED TO AND FORM A PART OF BOND NO. 4415890
BOND FOR SECURITY AND LABORERS AND MATERIALMEN

Wherein BEAUMONT SUNDANCE, LLC is named as Principal and SureTec Insurance Company, as Surety in favor of RIVERSIDE COUNTY FLOOD CONTROL AND WATER CONSERVATION DISTRICT as Obligee, in the amount of \$ 936,516.07 effective NOVEMBER 13, 2017 for HIGHLAND SPRINGS STORM DRAIN CHANNEL IMPROVEMENTS.

WHEREAS, when this bond was executed CITY OF BEAUMONT was named as Obligee, and

WHEREAS, it is now desired that certain other parties be added as Obligees.

NOW, THEREFORE, it is hereby understood and agreed that the following shall be considered as additional Obligees under this bond:

RIVERSIDE COUNTY FLOOD CONTROL AND WATER CONSERVATION DISTRICT

The foregoing, however, is subject to the following further provisions:

- (1) The Surety shall not be liable under this bond to the Obligees, or any of them, unless the said Obligees, or any of them, shall make payment to the Principal strictly in accordance with the term of said contract as to payments, and shall promptly perform all other obligations to be performed to by the first named obligee under said contract at the time and in the manner therein set forth.
- (2) The Principal and the Surety shall not be liable to any one or to all of the Obligees in the aggregate in excess of the penal sum of the bond, to wit: \$ 936,516.07.

Signed, and sealed this 13TH day of NOVEMBER, 2017.

BEAUMONT SUNDANCE, LLC
(Principal)

By: 
SOLOMON LEVY, MANAGING MEMBER
SureTec Insurance Company

By: 
MARK D. IATAROLA, Attorney-in-Fact

CALIFORNIA ALL-PURPOSE ACKNOWLEDGMENT

CIVIL CODE § 1189

A notary public or other officer completing this certificate verifies only the identity of the individual who signed the document to which this certificate is attached, and not the truthfulness, accuracy, or validity of that document.

State of California)
County of SAN DIEGO)

On 11/13/2017 before me, SANDRA FIGUEROA, NOTARY PUBLIC
Date Here Insert Name and Title of the Officer

personally appeared MARK D. IATAROLA
Name(s) of Signer(s)

who proved to me on the basis of satisfactory evidence to be the person(s) whose name(s) is/are subscribed to the within instrument and acknowledged to me that he/she/they executed the same in his/her/their authorized capacity(ies), and that by his/her/their signature(s) on the instrument the person(s), or the entity upon behalf of which the person(s) acted, executed the instrument.

I certify under PENALTY OF PERJURY under the laws of the State of California that the foregoing paragraph is true and correct.

WITNESS my hand and official seal.

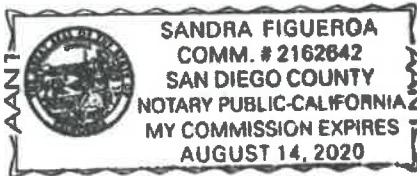

Signature Sandra Figueroa
Signature of Notary Public

Place Notary Seal Above

OPTIONAL

Though this section is optional, completing this information can deter alteration of the document or fraudulent reattachment of this form to an unintended document.

Description of Attached Document

Title or Type of Document: _____ Document Date: _____
Number of Pages: _____ Signer(s) Other Than Named Above: _____

Capacity(ies) Claimed by Signer(s)

Signer's Name: MARK D. IATAROLA
 Corporate Officer — Title(s): _____
 Partner — Limited General
 Individual Attorney in Fact
 Trustee Guardian or Conservator
 Other: _____
Signer Is Representing: _____

Signer's Name: _____
 Corporate Officer — Title(s): _____
 Partner — Limited General
 Individual Attorney in Fact
 Trustee Guardian or Conservator
 Other: _____
Signer Is Representing: _____

SureTec Insurance Company

LIMITED POWER OF ATTORNEY

Know All Men by These Presents, That SURETEC INSURANCE COMPANY (the "Company"), a corporation duly organized and existing under the laws of the State of Texas, and having its principal office in Houston, Harris County, Texas, does by these presents make, constitute and appoint

Helen Maloney, Mark D. Iatarola, John G. Maloney, Sandra Figueroa

its true and lawful Attorney-in-fact, with full power and authority hereby conferred in its name, place and stead, to execute, acknowledge and deliver any and all bonds, recognizances, undertakings or other instruments or contracts of suretyship to include waivers to the conditions of contracts and consents of surety for, providing the bond penalty does not exceed

Five Million and 00/100 Dollars (\$5,000,000.00)

and to bind the Company thereby as fully and to the same extent as if such bond were signed by the President, sealed with the corporate seal of the Company and duly attested by its Secretary, hereby ratifying and confirming all that the said Attorney-in-Fact may do in the premises. Said appointment shall continue in force until 12/31/2019 and is made under and by authority of the following resolutions of the Board of Directors of the SureTec Insurance Company:

Be it Resolved, that the President, any Vice-President, any Assistant Vice-President, any Secretary or any Assistant Secretary shall be and is hereby vested with full power and authority to appoint any one or more suitable persons as Attorney(s)-in-Fact to represent and act for and on behalf of the Company subject to the following provisions:

Attorney-in-Fact may be given full power and authority for and in the name of and of behalf of the Company, to execute, acknowledge and deliver, any and all bonds, recognizances, contracts, agreements or indemnity and other conditional or obligatory undertakings and any and all notices and documents canceling or terminating the Company's liability thereunder, and any such instruments so executed by any such Attorney-in-Fact shall be binding upon the Company as if signed by the President and sealed and effected by the Corporate Secretary.

Be it Resolved, that the signature of any authorized officer and seal of the Company heretofore or hereafter affixed to any power of attorney or any certificate relating thereto by facsimile, and any power of attorney or certificate bearing facsimile signature or facsimile seal shall be valid and binding upon the Company with respect to any bond or undertaking to which it is attached. *(Adopted at a meeting held on 20th of April, 1999.)*

In Witness Whereof, SURETEC INSURANCE COMPANY has caused these presents to be signed by its President, and its corporate seal to be hereto affixed this 16th day of January, A.D. 2017.

SURETEC INSURANCE COMPANY

By: 
John Knox Jr., President



State of Texas ss:
County of Harris

On this 16th day of January, A.D. 2017 before me personally came John Knox Jr., to me known, who, being by me duly sworn, did depose and say, that he resides in Houston, Texas, that he is President of SURETEC INSURANCE COMPANY, the company described in and which executed the above instrument; that he knows the seal of said Company; that the seal affixed to said instrument is such corporate seal; that it was so affixed by order of the Board of Directors of said Company; and that he signed his name thereto by like order.

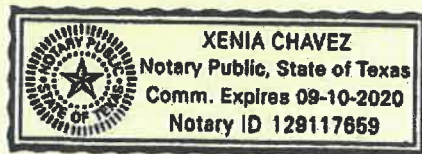

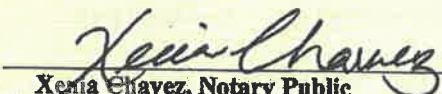
Xenia Chavez, Notary Public
My commission expires September 10, 2020

I, M. Brent Beaty, Assistant Secretary of SURETEC INSURANCE COMPANY, do hereby certify that the above and foregoing is a true and correct copy of a Power of Attorney, executed by said Company, which is still in full force and effect; and furthermore, the resolutions of the Board of Directors, set out in the Power of Attorney are in full force and effect.

Given under my hand and the seal of said Company at Houston, Texas this 13TH day of NOVEMBER, 2017, A.D.

M. Brent Beaty, Assistant Secretary

Any instrument issued in excess of the penalty stated above is totally void and without any validity.
For verification of the authority of this power you may call (713) 812-0860 any business day between 8:00 am and 5:00 pm CST.

CALIFORNIA ALL-PURPOSE CERTIFICATE OF ACKNOWLEDGMENT

State of California

County of San Diego

A notary public or other officer completing this certificate verifies only the identity of the individual who signed the document to which this certificate is attached, and not the truthfulness, accuracy, or validity of that document.

On NOVEMBER 17, 2017 before me, Joseph Conway, Notary Public,
(here insert name and title of the officer)

personally appeared SOLOMON LEVY

who proved to me on the basis of satisfactory evidence to be the person(s) whose name(s) ~~is~~ are subscribed to the within instrument and acknowledged to me that ~~he/she/they~~ he executed the same in ~~his/her/their~~ his authorized capacity(ies), and that by ~~his/her/their~~ his signature(s) on the instrument the person(s), or the entity upon behalf of which the person(s) acted, executed the instrument.

I certify under PENALTY OF PERJURY under the laws of the State of California that the foregoing paragraph is true and correct.

WITNESS my hand and official seal.

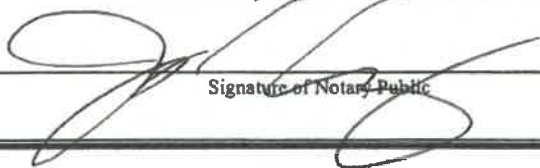
Signature of Notary Public



(Seal)

ADDITIONAL OPTIONAL INFORMATION

DESCRIPTION OF THE ATTACHED DOCUMENT

SURETEC BOND RIDER
(Title or description of attached document)

(Title or description of attached document continued)

Number of Pages _____ Document Date / /

(Additional information)

CAPACITY CLAIMED BY THE SIGNER

- Individual (s)
 Corporate Officer

(Title)

- Partner(s)
 Attorney-in-Fact
 Trustee(s)
 Other _____

INSTRUCTIONS FOR COMPLETING THIS FORM

Any acknowledgment completed in California must contain verbiage exactly as appears above in the notary section or a separate acknowledgment form must be properly completed and attached to that document. The only exception is if a document is to be recorded outside of California. In such instances, any alternative acknowledgment verbiage as may be printed on such a document so long as the verbiage does not require the notary to do something that is illegal for a notary in California (i.e. certifying the authorized capacity of the signer). Please check the document carefully for proper notarial wording and attach this form if required.

- State and County information must be the State and County where the document signer(s) personally appeared before the notary public for acknowledgment.
- Date of notarization must be the date that the signer(s) personally appeared which must also be the same date the acknowledgment is completed.
- The notary public must print his or her name as it appears within his or her commission followed by a comma and then your title (notary public).
- Print the name(s) of document signer(s) who personally appear at the time of notarization.
- Indicate the correct singular or plural forms by crossing off incorrect forms (i.e. ~~he/she/they~~, ~~is/are~~) or circling the correct forms. Failure to correctly indicate this information may lead to rejection of document recording.
- The notary seal impression must be clear and photographically reproducible. Impression must not cover text or lines. If seal impression smudges, re-seal if a sufficient area permits, otherwise complete a different acknowledgment form.
- Signature of the notary public must match the signature on file with the office of the county clerk.
 - ❖ Additional information is not required but could help to ensure this acknowledgment is not misused or attached to a different document.
 - ❖ Indicate title or type of attached document, number of pages and date.
 - ❖ Indicate the capacity claimed by the signer. If the claimed capacity is a corporate officer, indicate the title (i.e. CEO, CFO, Secretary).
- Securely attach this document to the signed document

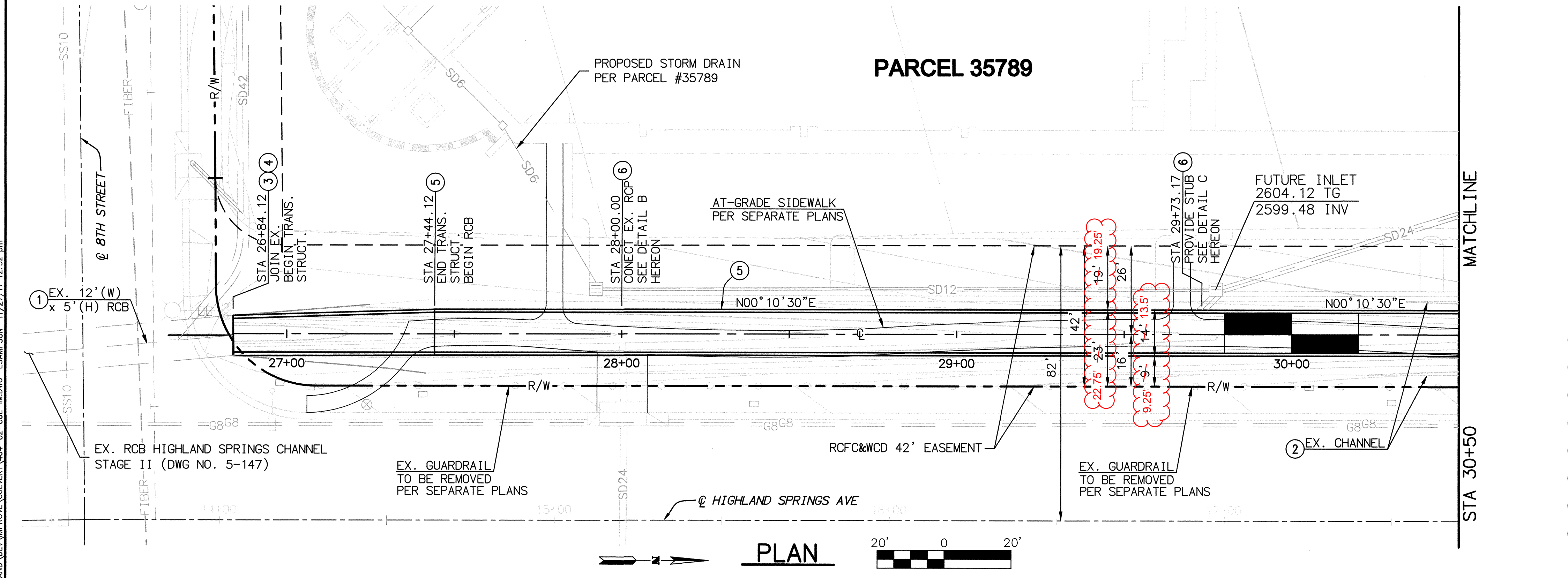
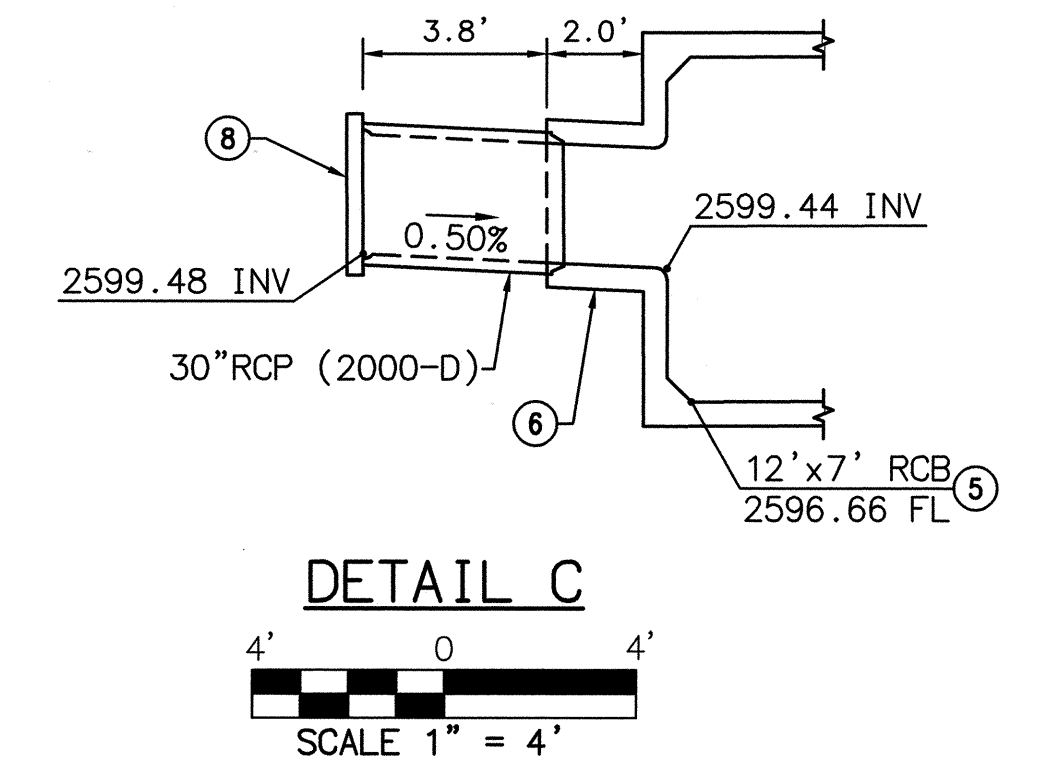
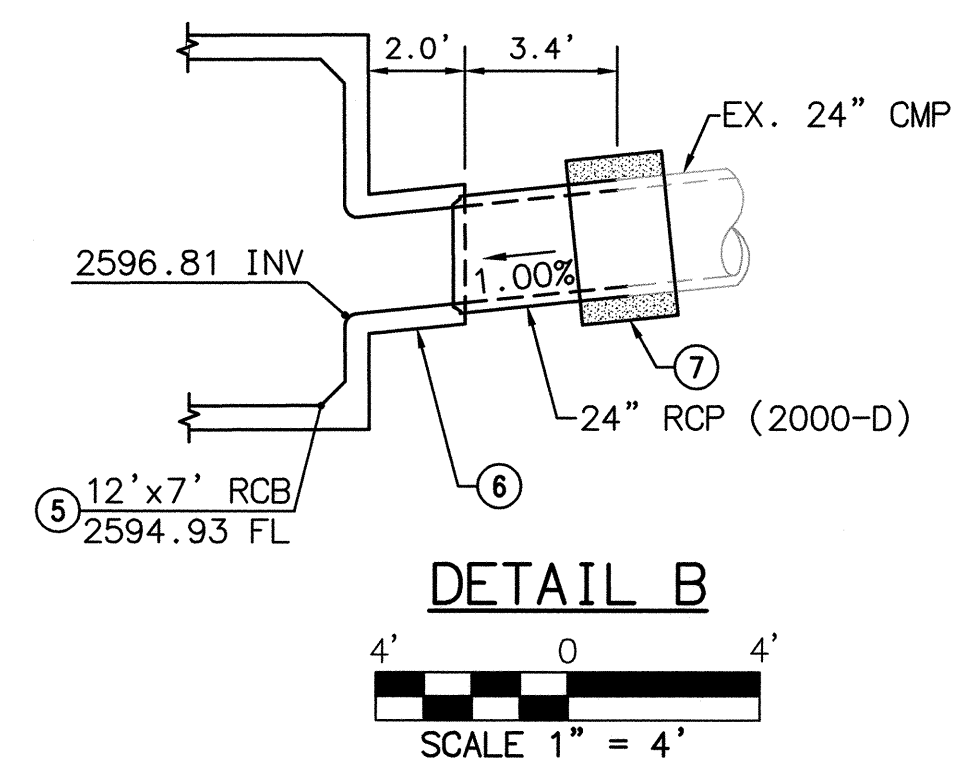
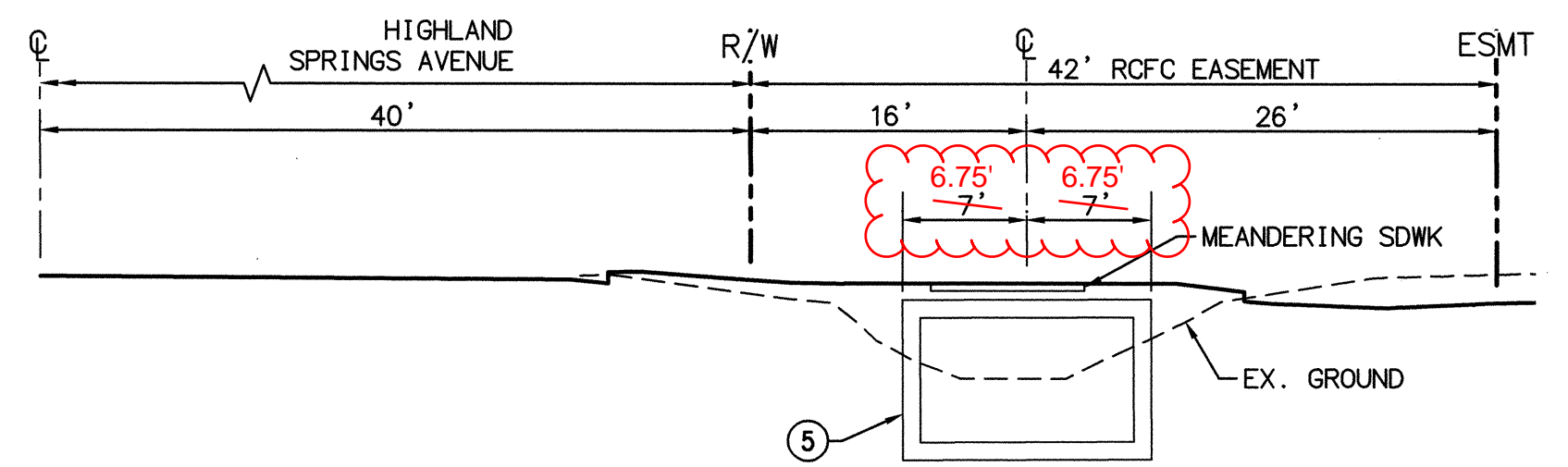
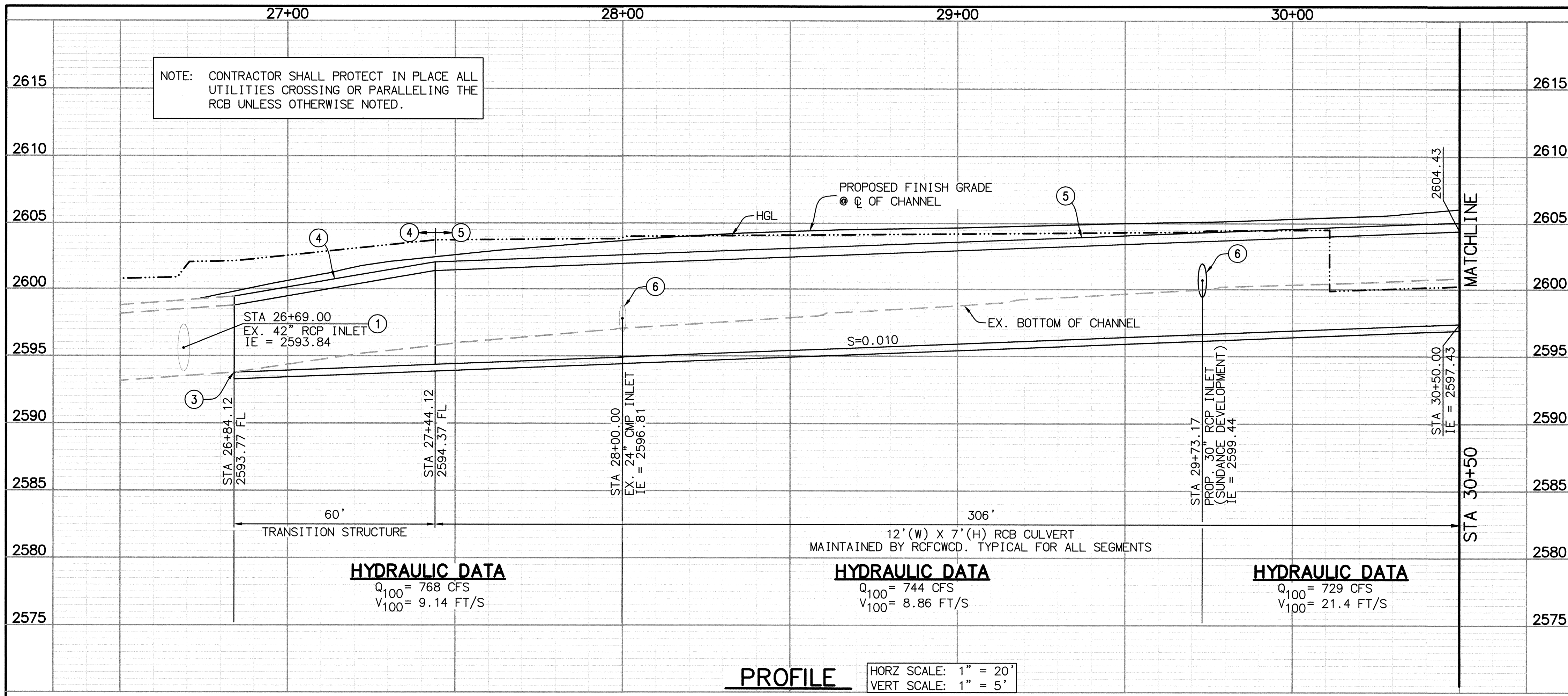

- CONSTRUCTION NOTES**
- PROTECT IN PLACE EXISTING
 - DEMOLISH AND REMOVE EXISTING. SEE DETAIL 3 ON SHEET 4
 - JOIN TO EX. 12'(W)X5'(H) RCB CULVERT PER DETAIL 1 ON SHEET 4
 - CONSTRUCT TRANSITION STRUCTURE PER RCFWCWD STD DWG TS302
 - CONSTRUCT 12'(W) X 7'(H) RCB CULVERT PER CALTRANS STD PLAN D80
 - CONSTRUCT JUNCTION STRUCTURE NO. 1 PER RCFWCWD STD DWG JS226
 - CONSTRUCT CONCRETE PIPE COLLAR PER RCFWCWD STD DWG M803
 - CONSTRUCT CONCRETE BULKHEAD PER RCFWCWD STD DWG M816

<p>Don't Dig...Until You Call U.S.A. Toll Free 1-800-227-2600 for the location of buried utility lines. Don't disrupt vital services. TWO WORKING DAYS BEFORE YOU DIG</p>	<p>PERMANENT BENCH MARK B.M. NO. 07.A.82 1-3/8" BRASS CAP MONUMENT MARKED "C1" B.M. 77. LOCATED AT THE S.E. CORNER 14TH AND PENNSYLVANIA AVE., 59 FT. S'LY AND 22 FT. E'LY OF C.I. INTERSECTION, 2 FT. S'LY OF B.C.R. 2678.28 EL. (1982)</p>	<p>APPROVED BY: Michael Baker INTERNATIONAL Timothy M. Thiele, RCE 60283 DATE: 12.18.17</p>	<p>5050 Avenida Encinas Suite 260 Carlsbad, CA 92008 Phone: (760) 476-9193 MBAKERINTL.COM DATE: 12.18.17</p>	<p>CITY OF BEAUMONT PUBLIC WORKS DEPARTMENT APPROVED BY: [Signature] DIRECTOR OF PUBLIC WORKS DATE: 1/11/18 PW2017-0089</p>	<p>REVISIONS</p> <table border="1"> <tr> <th>NO.</th> <th>DESCRIPTION</th> <th>APPR.</th> <th>DATE</th> </tr> <tr> <td> </td> <td> </td> <td> </td> <td> </td> </tr> </table>	NO.	DESCRIPTION	APPR.	DATE					<p>ENGINEER RCFC/</p>	<p>RIVERSIDE COUNTY FLOOD CONTROL AND WATER CONSERVATION DISTRICT RECOMMENDED FOR APPROVAL BY: [Signature] DATE: 1/8/2018 APPROVED BY: [Signature] DATE: 1/11/2018</p>	<p>AS-BUILT PARCEL MAP NO. 35789 HIGHLAND SPRINGS CHANNEL, STAGE 3 STA 26+84.12 TO STA 30+50.00</p>	<p>PROJECT NO. 5-0-00180 DRAWING NO. 5-0213 SHEET NO. 2 OF 4</p>
						NO.	DESCRIPTION	APPR.	DATE								
<p>PROJECT NO. 5-0-00180 DRAWING NO. 5-0213 SHEET NO. 2 OF 4</p>																	

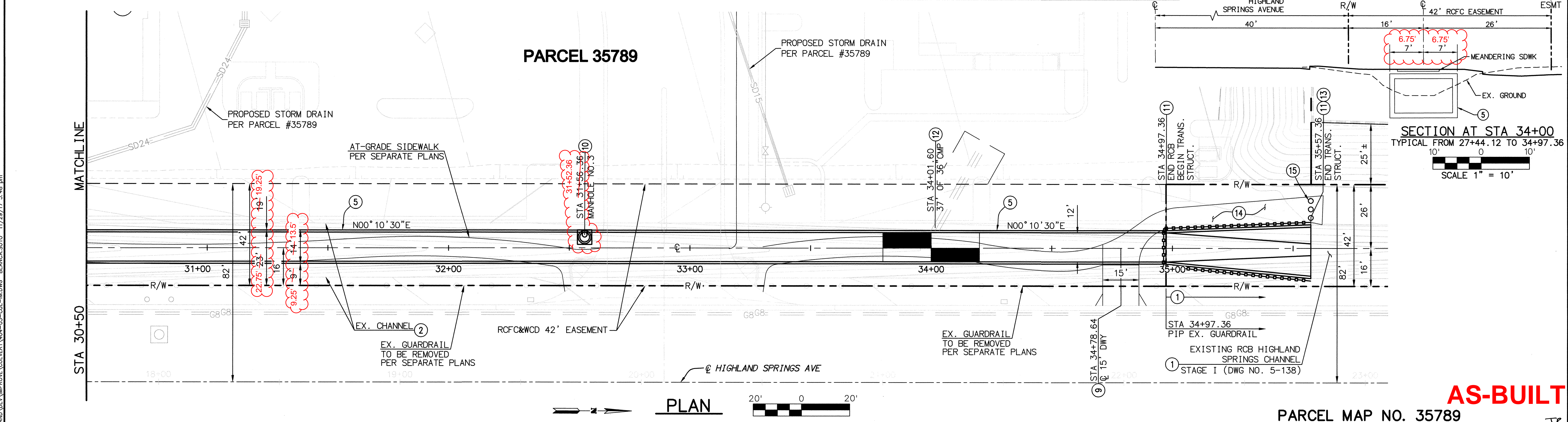
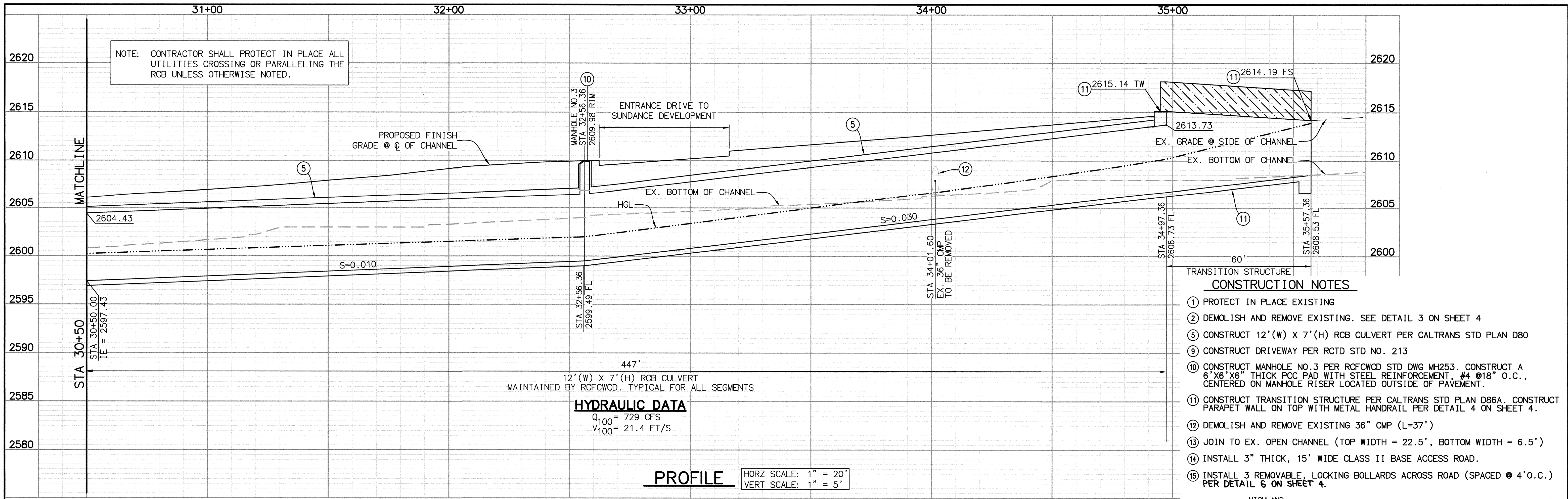

Don't Dig...Until You Call U.S.A. Toll Free 1-800-227-2600 for the location of buried utility lines. Don't disrupt vital services. TWO WORKING DAYS BEFORE YOU DIG

PERMANENT BENCH MARK
B.M. NO. 07.A.82
1-3/8" BRASS CAP MONUMENT MARKED "CITY B.M. 7", LOCATED AT THE S.E. CORNER 14TH AND PENNSYLVANIA AVE., 59 FT. S'LY AND 22 FT. ELY OF CL INTERSECTION, 2 FT. S'LY OF B.C.R.
2678.28 EL. (1982)

APPROVED BY:
Michael Baker INTERNATIONAL
TIMOTHY M. THIELE, RCE 60283

5050 Avenida Encinas
Suite 260
Carlsbad, CA 92008
Phone: (760) 476-9193
MBAKERINTL.COM
12-18-17
DATE:

CITY OF BEAUMONT
PUBLIC WORKS DEPARTMENT
APPROVED BY:
Tim Thiele
DIRECTOR OF PUBLIC WORKS
DATE: 1/14/18
PW2017-0089

REVISIONS

ENGINEER

RCFC/

RIVERSIDE COUNTY FLOOD CONTROL AND WATER CONSERVATION DISTRICT
RECOMMENDED FOR APPROVAL BY:
Deborah de Chambeau
DATE: 1/8/2018

APPROVED BY:
Shante P. Kild
DATE: 1/11/2018

PARCEL MAP NO. 35789

HIGHLAND SPRINGS CHANNEL, STAGE 3
STA 30+50.00 TO STA 35+57.36

PROJECT NO. 5-0-00180
DRAWING NO. 5-0213
SHEET NO. 3 OF 4

AS-BUILT

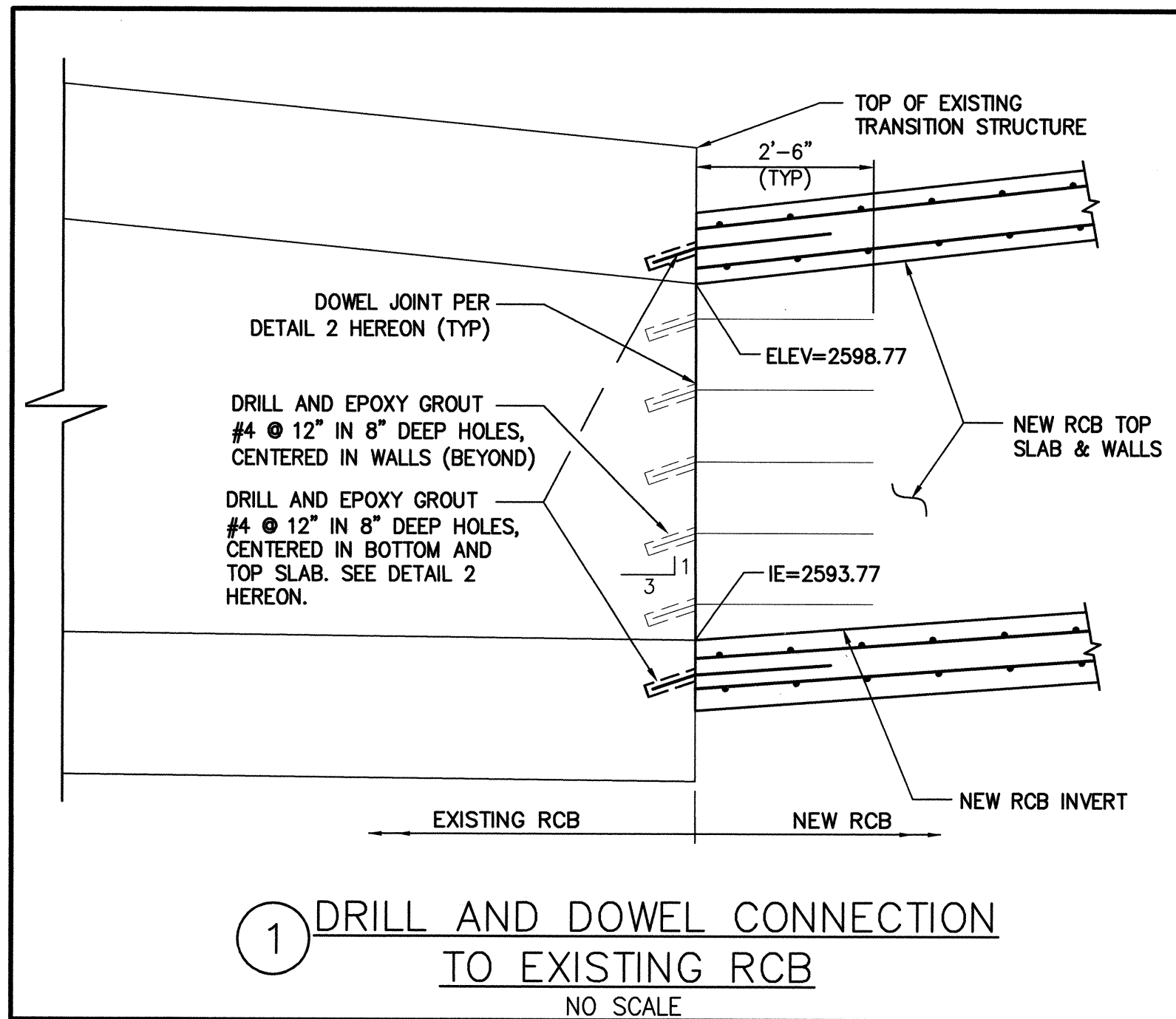

1 DRILL AND DOWEL CONNECTION TO EXISTING RCB
NO SCALE

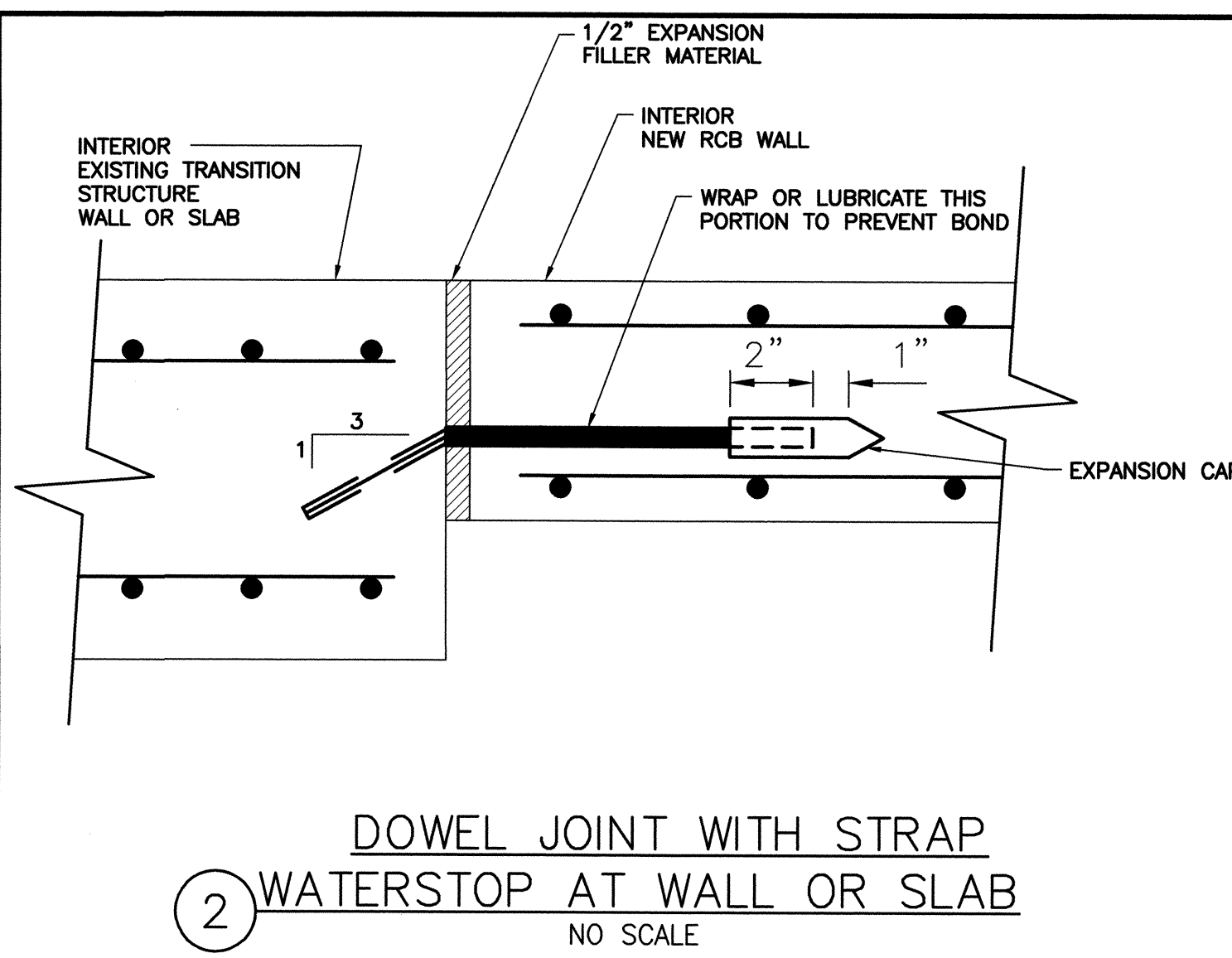

2 WATERSTOP AT WALL OR SLAB
NO SCALE

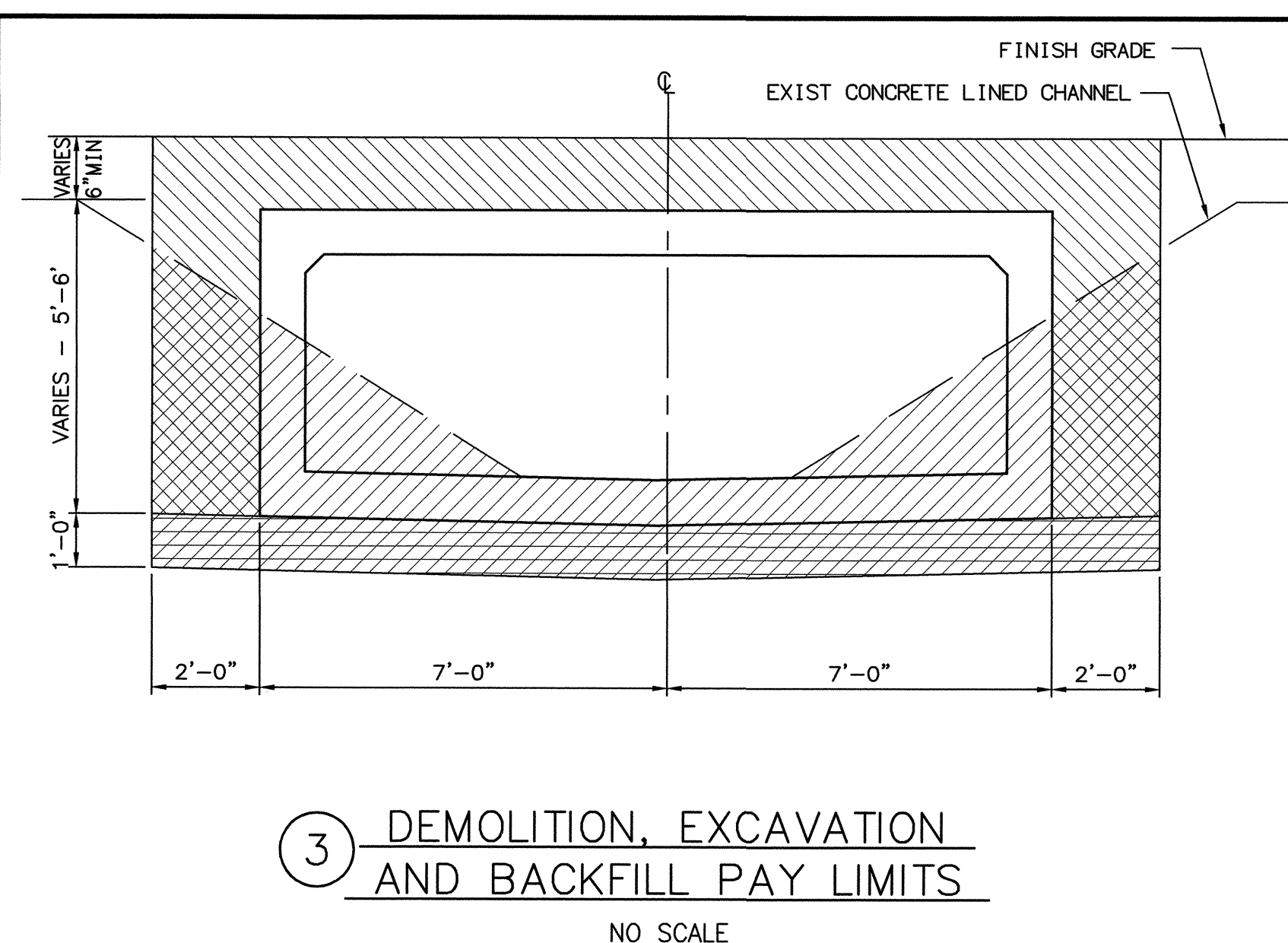

3 DEMOLITION, EXCAVATION AND BACKFILL PAY LIMITS
NO SCALE

LEGEND:

- EXCAVATION
- GRAVEL BASE. SEE GEOTECHNICAL REPORT SPECIFICATIONS
- STRUCTURAL BACKFILL (CULVERT). SEE GEOTECHNICAL REPORT SPECIFICATIONS
- EXCAVATION FOLLOWED BY STRUCTURAL BACKFILL (CULVERT). SEE GEOTECHNICAL REPORT SPECIFICATIONS

FOUNDATION NOTES:

1. FOUNDATION WORK SHALL CONFORM TO THE REQUIREMENTS OF:
 - A) THE SOIL REPORT AS PREPARED BY CONVERSE CONSULTANTS
TITLE: FOUNDATION REPORT
APPROXIMATELY 13.50-ACRE SITE, SUNDANCE CORPORATE CENTER
NORTHWEST CORNER OF HIGHLAND SPRINGS AVENUE AND 8th STREET
CITY OF BEAUMONT, RIVERSIDE COUNTY, CALIFORNIA
PROJECT NO. 08-81-117-01
DATED: FEBRUARY 25, 2008.
 - B) CONVERSE CONSULTANTS LETTER DATE OCTOBER 26, 2016.
2. THE CONTRACTOR SHALL NOTIFY THE GEOTECHNICAL ENGINEER OF ANY UNUSUAL SOIL CONDITIONS THAT ARE IN VARIANCE WITH THE DATA HEREIN CITED.
3. SOIL ENGINEER SHALL VERIFY THAT CONSTRUCTION AT THE SITE IS IN ACCORDANCE WITH THE RECOMMENDATIONS AND CONCLUSIONS OF HIS REPORT.
4. FINISHED EXCAVATIONS FOR FOUNDATION SHALL BE NEAT AND TRUE TO LINE WITH ALL LOOSE MATERIALS AND STANDING WATER REMOVED FROM EXCAVATION. SOIL BENEATH FOOTINGS SHALL BE REMOVED AND RECOMPACTED TO A DEPTH ENGINEER AS DIRECTED BY THE SOILS ENGINEER.
5. DESIGN VALUES:
2000 PSF ALLOWABLE SOIL BEARING PRESSURE.
NOTE: 12" MIN EMBEDMENT INTO LOWEST ADJACENT GRADE.
LATERAL EARTH PRESSURES:
35 PCF ACTIVE (DRAINED) FOR LEVEL BACKFILL
55 PCF AT-REST (DRAINED) FOR LEVEL BACKFILL
52 PCF ACTIVE (DRAINED) FOR 2:1 SLOPED BACKFILL
81 PCF AT-REST (DRAINED) FOR 2:1 SLOPED BACKFILL
250 PCF PASSIVE RESISTANCE
UNIT SOIL WEIGHT OF 120 PCF AND FRICTION COEFFICIENT BETWEEN CONCRETE AND SOIL OF 0.35.

CONCRETE NOTE:

REINFORCING STEEL AND CONCRETE SHALL BE PER MEMORANDUM OF UNDERSTANDING BETWEEN RCTD AND RCFWCDD FOR DESIGN, CONSTRUCTION, INSPECTION, AND MAINTENANCE OF FLOOD CONTROL DRAINAGE FACILITIES, DATED JUNE 24, 2008.

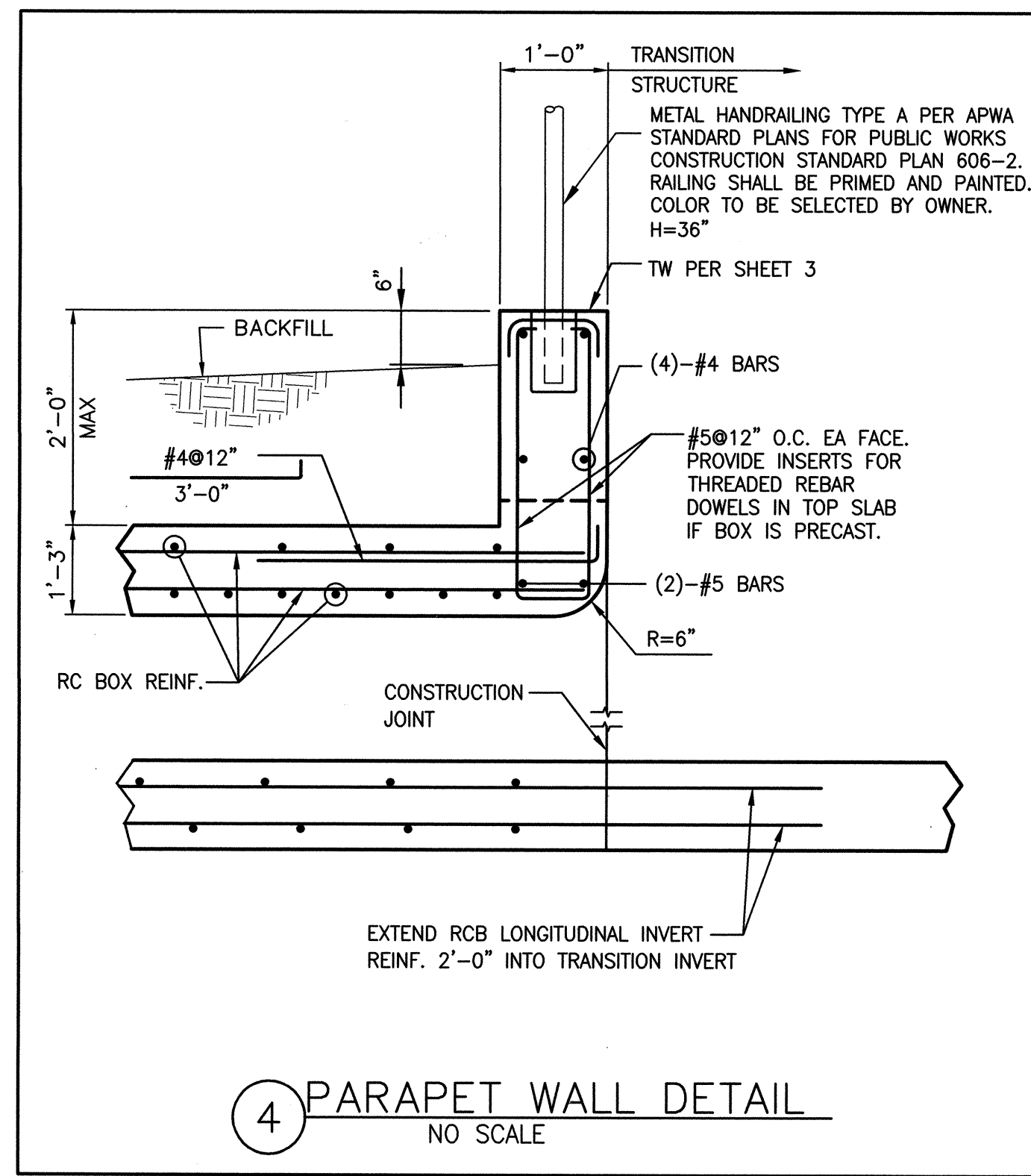

4 PARAPET WALL DETAIL
NO SCALE

STIRRUPS AND TIES

LAP SCHEDULE
f'c = 4,000psi
Fy = 60,000psi

BAR SIZE	TOP * BARS	OTHER BARS
#3	2'-7"	2'-0"
#4	3'-5"	2'-8"
#5	4'-3"	3'-3"
#6	5'-1"	3'-11"
#7	7'-5"	5'-9"
#8	8'-6"	6'-6"
#9	9'-7"	7'-4"
#10	10'-9"	8'-5"
#11	12'-0"	9'-2"

BEND SCHEDULE

BAR SIZES	D
#3 THRU #8	6d
#9 THRU #11	8d
#14 THRU #18	10d

d = DIAMETER OF REINF. BAR
* = TOP BARS ARE HORIZONTAL BARS WITH MORE THAN 12" OF CONCRETE CAST BELOW THE BAR, OR AS INDICATED ON PLANS.

LAP PER SCHED. ABV. UNLESS DETAILED OTHERWISE

1" OR 1.5d OR 1.33 MAX AGGREGATE WHICHEVER IS LARGEST

6 MAX. SLOPE & OFFSET

5 TYPICAL REINFORCEMENT DETAIL
NO SCALE

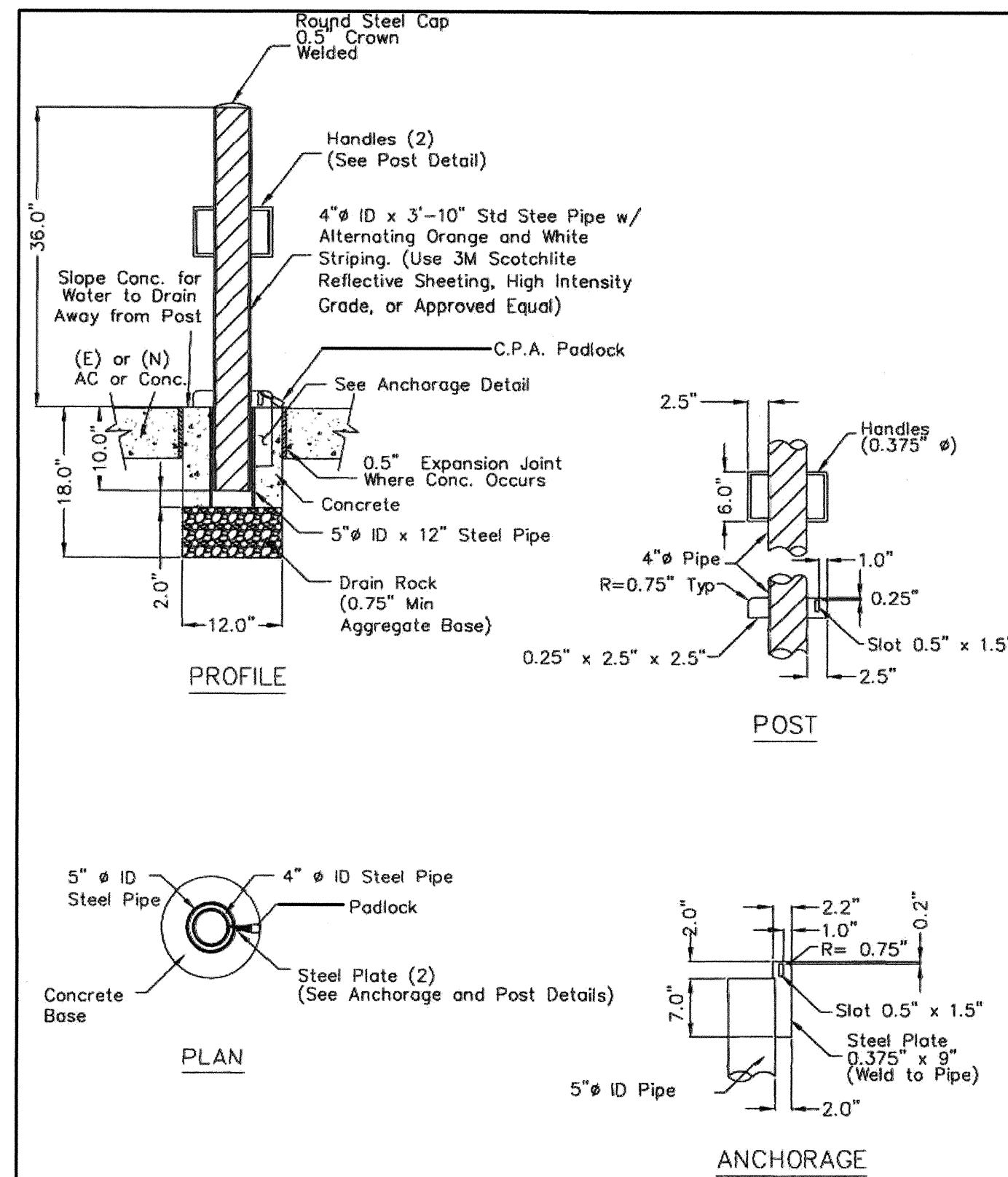

6 REMOVABLE BOLLARD DETAIL
NO SCALE

H:\DATA\5510046A\CADD\IMPROVE CULVERT\404-04-CUL-STR.DWG DWGNO: 12/20/17 2:34 pm

Don't Dig...Until You Call U.S.A. Toll Free
1-800-227-2600

PERMANENT BENCH MARK
B.M. NO. 07.A.82
1-3/8" BRASS CAP MONUMENT MARKED
"CITY B.M. 7". LOCATED AT THE S.E.
CORNER 14TH AND PENNSYLVANIA AVE.,
59 FT. S'LY AND 22 FT. E'LY OF CL
INTERSECTION, 2 FT. S'LY OF B.C.R.
2678.28 EL. (1982)

APPROVED BY:
Michael Baker
INTERNATIONAL
TIMOTHY W. THIELE, RCE 06283

5050 Avenida Encinas
Suite 260
Carlsbad, CA 92008
Phone: (760) 476-9193
MBAKERINTL.COM
12-18-17
DATE:

REGISTERED PROFESSIONAL ENGINEER
No. 060283
CIVIL
STATE OF CALIFORNIA

CITY OF BEAUMONT
PUBLIC WORKS DEPARTMENT

APPROVED BY:
[Signature]
DIRECTOR OF PUBLIC WORKS
DATE: 1/1/18

PW2018-0089

REVISIONS	ENGINEER	RCFC/

RIVERSIDE COUNTY FLOOD CONTROL
AND
WATER CONSERVATION DISTRICT

RECOMMENDED FOR APPROVAL BY:
[Signature]
DATE: 1/18/2018

APPROVED BY:
[Signature]
DATE: 1/11/2018

PARCEL MAP NO. 35789

AS-BUILT

HIGHLAND SPRINGS
CHANNEL, STAGE 3

STRUCTURAL DETAILS

PROJECT NO. 5-0-00180
DRAWING NO. 5-0213
SHEET NO. 4 OF 4