

FABRICATED CABINET WITH DIMENSIONAL LETTERS

QTY: 1

- FABRICATED ALUMINUM CABINET, PAINTED TO MATCH **MP11007 OLIVARY**.
- 3/4" THICK ACRYLIC COPY, PAINTED WHITE AND FLUSH MOUNTED TO SIGN FACE.
- MOUNTED TO STRUCTURAL BEAM WITH MOUNTING ANGLES & ANCHORS, AS NEEDED.



A | Proposed Construction
1 | Scale: 1" = 1'

COLORS & MATERIALS



MP11007 OLIVARY



A | Proposed Elevation
2 | Scale: NTS

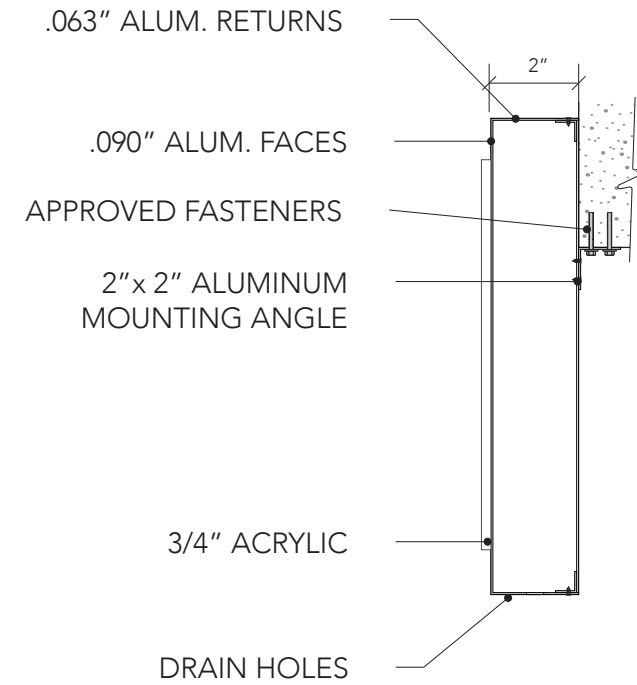

A | Cross Section
3 | Scale: NTS

SURVEY REQUIRED FOR OFFSET OF SIGN PLACEMENT

9/5/24: Revised to be non-lit sign with flush mounted FCO's. - WT



10212 METRIC BLVD.
AUSTIN, TEXAS 78758
877-293-6027 / 512-494-0002
fsg.com

City of Bastrop
300 Water St
Bastrop, TX 78602

Start Date: 07/10/24
Last Revision: 9/5/24 WT
Job# 3048517
Dwg. # 3048517 Av3s1

Designer: William T
Sales Rep: Michael G

CLIENT APPROVAL: I have reviewed and approved the sign details on this drawing for fabrication and installation.
© COPYRIGHT 2024 / ALL RIGHTS RESERVED



⊗ FOR PRESENTATION
○ FOR PRODUCTION

Av3s1