

Prepared for:
Ryan Reed
MISSOURI DOT
830 MoDOT Drive
605CO23000319
JEFFERSON CITY, MO 65109
Phone: (573) 751-3685

Prepared by:
Matt Pace
TRUCK CENTERS, INC.
2280 FORMOSA RD.
TROY, IL 62294
Phone: 618-667-3454

A proposal for
MISSOURI DOT

Prepared by
TRUCK CENTERS, INC.
Matt Pace

Dec 18, 2022

Freightliner 108SD



Components shown may not reflect all spec'd options and are not to scale

Prepared for:
 Ryan Reed
 MISSOURI DOT
 830 MoDOT Drive
 605CO23000319
 JEFFERSON CITY, MO 65109
 Phone: (573) 751-3685

Prepared by:
 Matt Pace
 TRUCK CENTERS, INC.
 2280 FORMOSA RD.
 TROY, IL 62294
 Phone: 618-667-3454

Q U O T A T I O N

108SD CONVENTIONAL CHASSIS

SET BACK AXLE - TRUCK
 CUM L9 330 HP @ 2200 RPM; 2200 GOV RPM, 1000 LB-
 FT @ 1200 RPM
 ALLISON 3500 RDS AUTOMATIC TRANSMISSION WITH
 PTO PROVISION
 S23-170E 23,000# R-SERIES HIGH ENTRY SINGLE REAR
 AXLE
 26,000# FLAT LEAF SPRING REAR SUSPENSION WITH
 RADIUS ROD
 DETROIT DA-F-14.7-3 14,700# FF1 71.5 KPI/3.74 DROP
 SINGLE FRONT AXLE
 14,600# TAPERLEAF FRONT SUSPENSION
 108 INCH BBC FLAT ROOF ALUMINUM CONVENTIONAL
 CAB
 4575MM (180 INCH) WHEELBASE
 7/16X3-9/16X11-1/8 INCH STEEL FRAME
 (11.11MMX282.6MM/0.437X11.13 INCH) 120KSI
 1650MM (65 INCH) REAR FRAME OVERHANG
 TEM TO EVALUATE AND INSTALL FRAME RAIL
 REINFORCEMENT AS NEEDED FOR FRONT
 FRAME MOUNTED EQUIPMENT
 HENDRICKSON EX20 COMP 20,000# FL1 STEERABLE
 16.5X6 BRAKE INTEGRAL PUSHER AXLE

		PER UNIT		TOTAL
VEHICLE PRICE	TOTAL # OF UNITS (1)	\$	102,960 \$	102,960
EXTENDED WARRANTY		\$	405 \$	405
DEALER INSTALLED OPTIONS		\$	0 \$	0
CUSTOMER PRICE BEFORE TAX		\$	103,365 \$	103,365

TAXES AND FEES

TAXES AND FEES	\$	0 \$	0
OTHER CHARGES	\$	0 \$	0

TRADE-IN

TRADE-IN ALLOWANCE	\$	(0) \$	(0)
---------------------------	----	--------	-----

BALANCE DUE	(LOCAL CURRENCY) \$	103,365 \$	103,365
--------------------	----------------------------	-------------------	----------------

COMMENTS:

Projected delivery on ___ / ___ / ___ provided the order is received before ___ / ___ / ___.

APPROVAL:

Please indicate your acceptance of this quotation by signing below:

Prepared for:
Ryan Reed
MISSOURI DOT
830 MoDOT Drive
605CO23000319
JEFFERSON CITY, MO 65109
Phone: (573) 751-3685

Prepared by:
Matt Pace
TRUCK CENTERS, INC.
2280 FORMOSA RD.
TROY, IL 62294
Phone: 618-667-3454

Customer: X _____ Date: ___ / ___ / ___.

Daimler Truck Financial

Financing that works for you.

See your local dealer for a competitive quote from Daimler Truck Financial, or contact us at Information@dtfoffers.com.

Daimler Truck Financial offers a variety of finance, lease and insurance solutions to fit your business needs. For more information about our products and services, visit our website at www.daimler-truckfinancial.com.

Prepared for:
 Ryan Reed
 MISSOURI DOT
 830 MoDOT Drive
 605CO23000319
 JEFFERSON CITY, MO 65109
 Phone: (573) 751-3685

Prepared by:
 Matt Pace
 TRUCK CENTERS, INC.
 2280 FORMOSA RD.
 TROY, IL 62294
 Phone: 618-667-3454

S P E C I F I C A T I O N P R O P O S A L

Data Code	Description	Weight Front	Weight Rear	Retail Price
Price Level				
PRL-27D	SD PRL-27D (EFF:MY24 ORDERS)			STD
Data Version				
DRL-024	SPECPRO21 DATA RELEASE VER 024			N/C
Vehicle Configuration				
001-176	108SD CONVENTIONAL CHASSIS	6,829	3,748	\$124,670.00
004-224	2024 MODEL YEAR SPECIFIED			STD
002-004	SET BACK AXLE - TRUCK			STD
019-001	TRAILER TOWING PROVISION AT END OF FRAME FOR TRUCK	10	10	\$1,025.00
003-001	LH PRIMARY STEERING LOCATION			STD
General Service				
AA1-003	TRUCK/TRAILER CONFIGURATION			N/C
AA6-002	DOMICILED, USA (EXCLUDING CALIFORNIA AND CARB OPT-IN STATES)			N/C
A85-010	UTILITY/REPAIR/MAINTENANCE SERVICE			N/C
A84-1GM	GOVERNMENT BUSINESS SEGMENT			N/C
AA4-010	DIRT/SAND/ROCK COMMODITY			N/C
AA5-002	TERRAIN/DUTY: 100% (ALL) OF THE TIME, IN TRANSIT, IS SPENT ON PAVED ROADS			STD
AB1-008	MAXIMUM 8% EXPECTED GRADE			STD
AB5-001	SMOOTH CONCRETE OR ASPHALT PAVEMENT - MOST SEVERE IN-TRANSIT (BETWEEN SITES) ROAD SURFACE			STD
995-1A0	FREIGHTLINER SD VOCATIONAL WARRANTY			STD
A66-99D	EXPECTED FRONT AXLE(S) LOAD : 14600.0 lbs			
A68-99D	EXPECTED REAR DRIVE AXLE(S) LOAD : 23000.0 lbs			
A67-99D	EXPECTED PUSHER AXLE(S) LOAD : 12350.0 lbs			
A63-99D	EXPECTED GROSS VEHICLE WEIGHT CAPACITY : 49950.0 lbs			

Prepared for:
 Ryan Reed
 MISSOURI DOT
 830 MoDOT Drive
 605CO23000319
 JEFFERSON CITY, MO 65109
 Phone: (573) 751-3685

Prepared by:
 Matt Pace
 TRUCK CENTERS, INC.
 2280 FORMOSA RD.
 TROY, IL 62294
 Phone: 618-667-3454

A70-99D EXPECTED GROSS COMBINATION WEIGHT :
 65000.0 lbs

Truck Service

AA3-018	FRONT PLOW/END DUMP BODY	N/C
AF3-2B1	VIKING-CIVES MIDWEST	N/C

Engine

101-3BP	CUM L9 330 HP @ 2200 RPM; 2200 GOV RPM, 1000 LB-FT @ 1200 RPM	\$3,051.00
---------	--	------------

Electronic Parameters

79A-065	65 MPH ROAD SPEED LIMIT	N/C
79B-000	CRUISE CONTROL SPEED LIMIT SAME AS ROAD SPEED LIMIT	N/C
79K-007	PTO MODE ENGINE RPM LIMIT - 1100 RPM	N/C
79M-001	PTO MODE BRAKE OVERRIDE - SERVICE BRAKE APPLIED	N/C
79P-002	PTO RPM WITH CRUISE SET SWITCH - 700 RPM	N/C
79Q-002	PTO RPM WITH CRUISE RESUME SWITCH - 700 RPM	N/C
79S-001	PTO MODE CANCEL VEHICLE SPEED - 5 MPH	N/C
79U-007	PTO GOVERNOR RAMP RATE - 250 RPM PER SECOND	N/C
80G-002	PTO MINIMUM RPM - 700	N/C
80J-002	REGEN INHIBIT SPEED THRESHOLD - 5 MPH	N/C

Engine Equipment

99C-021	2010 EPA/CARB/GHG21 CONFIGURATION	STD
99D-010	NO 2008 CARB EMISSION CERTIFICATION	N/C
13E-001	STANDARD OIL PAN	STD
105-001	ENGINE MOUNTED OIL CHECK AND FILL	STD
014-1B5	SIDE OF HOOD AIR INTAKE WITH DONALDSON HIGH CAPACITY AIR CLEANER WITH SAFETY ELEMENT, FIREWALL MOUNTED	\$25.00
124-1E1	DR 12V 200 AMP 28-SI QUADRAMOUNT PAD ALTERNATOR WITH REMOTE BATTERY VOLT SENSE	\$143.00
292-235	(2) DTNA GENUINE, FLOODED STARTING, MIN 2000CCA, 370RC, THREADED STUD BATTERIES	STD
290-017	BATTERY BOX FRAME MOUNTED	STD
281-001	STANDARD BATTERY JUMPERS	STD
282-001	SINGLE BATTERY BOX FRAME MOUNTED LH SIDE UNDER CAB	\$18.00
291-017	WIRE GROUND RETURN FOR BATTERY CABLES WITH ADDITIONAL FRAME GROUND RETURN	STD
289-001	NON-POLISHED BATTERY BOX COVER	STD

Prepared for:
 Ryan Reed
 MISSOURI DOT
 830 MoDOT Drive
 605CO23000319
 JEFFERSON CITY, MO 65109
 Phone: (573) 751-3685

Prepared by:
 Matt Pace
 TRUCK CENTERS, INC.
 2280 FORMOSA RD.
 TROY, IL 62294
 Phone: 618-667-3454

87P-001	CAB AUXILIARY POWER CABLE	5		\$62.00
107-032	CUMMINS TURBOCHARGED 18.7 CFM AIR COMPRESSOR WITH INTERNAL SAFETY VALVE			STD
152-041	ELECTRONIC ENGINE INTEGRAL SHUTDOWN PROTECTION SYSTEM			STD
128-076	CUMMINS ENGINE INTEGRAL BRAKE WITH VARIABLE GEOMETRY TURBO ON/OFF	20		STD
016-1C2	RH OUTBOARD UNDER STEP MOUNTED HORIZONTAL AFTERTREATMENT SYSTEM ASSEMBLY WITH RH B-PILLAR MOUNTED VERTICAL TAILPIPE	30	25	\$816.00
28F-002	ENGINE AFTERTREATMENT DEVICE, AUTOMATIC OVER THE ROAD REGENERATION AND DASH MOUNTED REGENERATION REQUEST SWITCH			STD
239-026	10 FOOT 06 INCH (126 INCH+0/-5.9 INCH) EXHAUST SYSTEM HEIGHT			(\$3.00)
237-1CR	RH CURVED VERTICAL TAILPIPE B-PILLAR MOUNTED ROUTED FROM STEP			N/C
23U-001	6 GALLON DIESEL EXHAUST FLUID TANK	-35	-10	N/C
30N-003	100 PERCENT DIESEL EXHAUST FLUID FILL			(\$17.00)
23Y-001	STANDARD DIESEL EXHAUST FLUID PUMP MOUNTING			STD
43X-002	LH MEDIUM DUTY STANDARD DIESEL EXHAUST FLUID TANK LOCATION			STD
43Y-001	STANDARD DIESEL EXHAUST FLUID TANK CAP			STD
242-011	ALUMINUM AFTERTREATMENT DEVICE/MUFFLER/TAILPIPE SHIELD(S)			N/C
273-060	HIGH SPEED AIR POWERED ON/OFF ENGINE FAN CLUTCH			\$252.00
276-001	AUTOMATIC FAN CONTROL WITHOUT DASH SWITCH, NON ENGINE MOUNTED			STD
110-003	CUMMINS SPIN ON FUEL FILTER			STD
118-008	COMBINATION FULL FLOW/BYPASS OIL FILTER			STD
266-104	1115 SQUARE INCH ALUMINUM RADIATOR			STD
103-039	ANTIFREEZE TO -34F, OAT (NITRITE AND SILICATE FREE) EXTENDED LIFE COOLANT			STD
171-007	GATES BLUE STRIPE COOLANT HOSES OR EQUIVALENT			STD
172-001	CONSTANT TENSION HOSE CLAMPS FOR COOLANT HOSES			STD
270-016	RADIATOR DRAIN VALVE			STD
138-011	PHILLIPS-TEMRO 1000 WATT/115 VOLT BLOCK HEATER	4		\$92.00
140-053	BLACK PLASTIC ENGINE HEATER RECEPTACLE MOUNTED UNDER LH DOOR			N/C
132-004	ELECTRIC GRID AIR INTAKE WARMER			STD

Prepared for:
 Ryan Reed
 MISSOURI DOT
 830 MoDOT Drive
 605CO23000319
 JEFFERSON CITY, MO 65109
 Phone: (573) 751-3685

Prepared by:
 Matt Pace
 TRUCK CENTERS, INC.
 2280 FORMOSA RD.
 TROY, IL 62294
 Phone: 618-667-3454

155-058	DELCO 12V 38MT HD STARTER WITH INTEGRATED MAGNETIC SWITCH	STD
Transmission		
342-584	ALLISON 3500 RDS AUTOMATIC TRANSMISSION WITH PTO PROVISION	(\$75.00)
Transmission Equipment		
343-339	ALLISON VOCATIONAL PACKAGE 223 - AVAILABLE ON 3000/4000 PRODUCT FAMILIES WITH VOCATIONAL MODELS RDS, HS, MH AND TRV	STD
84B-012	ALLISON VOCATIONAL RATING FOR ON/OFF HIGHWAY APPLICATIONS AVAILABLE WITH ALL PRODUCT FAMILIES	N/C
84C-023	PRIMARY MODE GEARS, LOWEST GEAR 1, START GEAR 1, HIGHEST GEAR 6, AVAILABLE FOR 3000/4000 PRODUCT FAMILIES ONLY	STD
84D-023	SECONDARY MODE GEARS, LOWEST GEAR 1, START GEAR 1, HIGHEST GEAR 6, AVAILABLE FOR 3000/4000 PRODUCT FAMILIES ONLY	STD
84E-017	S5 PERFORMANCE LIMITING PRIMARY SHIFT SCHEDULE, AVAILABLE FOR 3000/4000 PRODUCT FAMILIES ONLY	N/C
84F-016	S5 PERFORMANCE LIMITING SECONDARY SHIFT SCHEDULE, AVAILABLE FOR 3000/4000 PRODUCT FAMILIES ONLY	N/C
84G-013	2100 RPM PRIMARY MODE SHIFT SPEED	N/C
84H-014	2200 RPM SECONDARY MODE SHIFT SPEED	N/C
84N-200	FUEL SENSE 2.0 DISABLED - PERFORMANCE - TABLE BASED	STD
84U-000	DRIVER SWITCH INPUT - DEFAULT - NO SWITCHES	STD
353-026	VEHICLE INTERFACE WIRING CONNECTOR WITH PDM AND NO BLUNT CUTS, AT BACK OF CAB	\$574.00
34C-001	ELECTRONIC TRANSMISSION CUSTOMER ACCESS CONNECTOR FIREWALL MOUNTED	\$23.00
362-824	(2) CUSTOMER INSTALLED CHELSEA 280 SERIES PTO'S	N/C
363-011	PTO MOUNTING, LH AND RH SIDES OF MAIN TRANSMISSION	N/C
341-018	MAGNETIC PLUGS, ENGINE DRAIN, TRANSMISSION DRAIN, AXLE(S) FILL AND DRAIN	STD
345-003	PUSH BUTTON ELECTRONIC SHIFT CONTROL, DASH MOUNTED	STD
97G-004	TRANSMISSION PROGNOSTICS - ENABLED 2013	STD

Prepared for:
 Ryan Reed
 MISSOURI DOT
 830 MoDOT Drive
 605CO23000319
 JEFFERSON CITY, MO 65109
 Phone: (573) 751-3685

Prepared by:
 Matt Pace
 TRUCK CENTERS, INC.
 2280 FORMOSA RD.
 TROY, IL 62294
 Phone: 618-667-3454

370-015	WATER TO OIL TRANSMISSION COOLER, IN RADIATOR END TANK			STD
346-003	TRANSMISSION OIL CHECK AND FILL WITH ELECTRONIC OIL LEVEL CHECK			STD
35T-001	SYNTHETIC TRANSMISSION FLUID (TES-295 COMPLIANT)			STD

Front Axle and Equipment

400-1A8	DETROIT DA-F-14.7-3 14,700# FF1 71.5 KPI/3.74 DROP SINGLE FRONT AXLE	10		\$980.00
402-049	MERITOR 16.5X5 Q+ CAST SPIDER CAM FRONT BRAKES, DOUBLE ANCHOR, FABRICATED SHOES			N/C
403-002	NON-ASBESTOS FRONT BRAKE LINING			STD
419-023	CONMET CAST IRON FRONT BRAKE DRUMS			\$8.00
427-001	FRONT BRAKE DUST SHIELDS	5		\$102.00
409-006	FRONT OIL SEALS			STD
408-001	VENTED FRONT HUB CAPS WITH WINDOW, CENTER AND SIDE PLUGS - OIL			STD
416-022	STANDARD SPINDLE NUTS FOR ALL AXLES			STD
405-002	MERITOR AUTOMATIC FRONT SLACK ADJUSTERS			STD
406-001	STANDARD KING PIN BUSHINGS			STD
536-012	TRW TAS-85 POWER STEERING	40		N/C
539-003	POWER STEERING PUMP			STD
534-015	2 QUART SEE THROUGH POWER STEERING RESERVOIR			STD
40T-002	CURRENT AVAILABLE SYNTHETIC 75W-90 FRONT AXLE LUBE			\$17.00

Front Suspension

620-010	14,600# TAPERLEAF FRONT SUSPENSION	170		\$484.00
619-005	MAINTENANCE FREE RUBBER BUSHINGS - FRONT SUSPENSION			STD
410-001	FRONT SHOCK ABSORBERS			STD

Rear Axle and Equipment

420-1U6	S23-170E 23,000# R-SERIES HIGH ENTRY SINGLE REAR AXLE	180		\$4,813.00
421-614	6.14 REAR AXLE RATIO			N/C
424-001	IRON REAR AXLE CARRIER WITH STANDARD AXLE HOUSING			STD
386-073	MXL 17T MERITOR EXTENDED LUBE MAIN DRIVELINE WITH HALF ROUND YOKES	20	20	STD
423-019	MERITOR 16.5X8.82 Q+ CAST SPIDER CAM REAR BRAKES, DOUBLE ANCHOR, FABRICATED SHOES			\$156.00

Prepared for:
 Ryan Read
 MISSOURI DOT
 830 MoDOT Drive
 605CO23000319
 JEFFERSON CITY, MO 65109
 Phone: (573) 751-3685

Prepared by:
 Matt Pace
 TRUCK CENTERS, INC.
 2280 FORMOSA RD.
 TROY, IL 62294
 Phone: 618-667-3454

433-002	NON-ASBESTOS REAR BRAKE LINING		STD
434-011	BRAKE CAMS AND CHAMBERS ON FORWARD SIDE OF DRIVE AXLE(S)		N/C
451-023	CONMET CAST IRON REAR BRAKE DRUMS		\$27.00
425-002	REAR BRAKE DUST SHIELDS	5	\$130.00
440-006	REAR OIL SEALS		STD
426-100	WABCO TRISTOP D LONGSTROKE 1-DRIVE AXLE SPRING PARKING CHAMBERS		STD
428-002	MERITOR AUTOMATIC REAR SLACK ADJUSTERS		STD
41T-002	CURRENT AVAILABLE SYNTHETIC 75W-90 REAR AXLE LUBE		STD
42T-001	STANDARD REAR AXLE BREATHER(S)		STD

Rear Suspension

622-1DA	26,000# FLAT LEAF SPRING REAR SUSPENSION WITH RADIUS ROD	40	\$141.00
621-006	SPRING SUSPENSION - 2.25 INCH AXLE SPACER	10	\$247.00
431-001	STANDARD AXLE SEATS IN AXLE CLAMP GROUP		STD
623-005	FORE/AFT CONTROL RODS		STD

Pusher / Tag Equipment

*	035-129	HENDRICKSON EX20 COMP 20,000# AIR LIFT STEERABLE PUSHER SUSPENSION, 16.5X6 BRAKES, FL1 AXLE	695	1,290	\$12,222.00
	443-127	HENDRICKSON EX20 COMP 20,000# FL1 STEERABLE 16.5X6 BRAKE INTEGRAL PUSHER AXLE			N/C
	874-015	(1) DASH VALVE AND (1) GAUGE FOR SINGLE LIFT AXLE			N/C
	87F-005	LIFT AXLE WIRING, LIFT IN REVERSE, WITH LAST STATE RETENTION WITH IGNITION OFF			N/C
	896-014	(1)REGULATOR MOUNTED ON CHASSIS FOR SINGLE LIFT AXLE			N/C
	456-1AF	HENDRICKSON 16.5X6 CAST SPIDER CAM PUSHER/TAG BRAKES, DOUBLE ANCHOR, FABRICATED SHOES			N/C
	457-002	NON-ASBESTOS PUSHER/TAG BRAKE LINING			N/C
	448-023	CONMET CAST IRON PUSHER/TAG BRAKE DRUMS			N/C
	429-001	PUSHER/TAG BRAKE DUST SHIELDS		5	N/C
	442-016	PUSHER/TAG OIL SEALS			N/C
	444-001	VENTED PUSHER/TAG HUB CAPS WITH WINDOW, CENTER AND SIDE PLUGS - OIL			N/C

Prepared for:
 Ryan Reed
 MISSOURI DOT
 830 MoDOT Drive
 605CO23000319
 JEFFERSON CITY, MO 65109
 Phone: (573) 751-3685

Prepared by:
 Matt Pace
 TRUCK CENTERS, INC.
 2280 FORMOSA RD.
 TROY, IL 62294
 Phone: 618-667-3454

445-075	HALDEX LONGSTROKE PUSHER/TAG AXLE SERVICE CHAMBERS	N/C
458-003	HALDEX AUTOMATIC PUSHER/TAG SLACK ADJUSTERS	N/C
626-132	HENDRICKSON EX20 COMP 20,000# AIR LIFT STEERABLE PUSHER SUSPENSION	N/C
627-001	52 INCH AXLE SPACING PUSHER/TAG	N/C

Brake System

490-100	WABCO 4S/4M ABS	STD
871-001	REINFORCED NYLON, FABRIC BRAID AND WIRE BRAID CHASSIS AIR LINES	STD
904-001	FIBER BRAID PARKING BRAKE HOSE	STD
412-001	STANDARD BRAKE SYSTEM VALVES	STD
46D-002	STANDARD AIR SYSTEM PRESSURE PROTECTION SYSTEM	STD
413-002	STD U.S. FRONT BRAKE VALVE	STD
* 432-021	(2) 3-4.5 PSI RELAY VALVES, ONE FOR TANDEM AXLE AND ONE FOR PUSHER/TAG	N/C
480-086	BW AD-9SI BRAKE LINE AIR DRYER WITH HEATER	\$2.00
479-003	AIR DRYER MOUNTED INBOARD ON LH RAIL	N/C
460-001	STEEL AIR BRAKE RESERVOIRS	STD
477-036	PULL CABLES ON ALL AIR RESERVOIRS WITH KEY RING TYPE ATTACHMENT	\$3.00

Trailer Connections

914-001	AIR CONNECTIONS TO END OF FRAME WITH GLAD HANDS FOR TRUCK AND NO DUST COVERS	N/C
296-027	PRIMARY CONNECTOR/RECEPTACLE WIRED FOR COMBINATION STOP/TURN, CENTER PIN POWERED THROUGH IGNITION WITH STOP SIGNAL PREWIRE PACKAGE	\$59.00
297-001	SAE J560 7-WAY PRIMARY TRAILER CABLE RECEPTACLE MOUNTED END OF FRAME	N/C
335-004	UPGRADED CHASSIS MULTIPLEXING UNIT	STD

Wheelbase & Frame

545-457	4575MM (180 INCH) WHEELBASE	N/C
* 546-102	7/16X3-9/16X11-1/8 INCH STEEL FRAME (11.11MMX282.6MM/0.437X11.13 INCH) 120KSI	240 130 \$720.00
548-803	TEM TO EVALUATE AND INSTALL FRAME RAIL REINFORCEMENT AS NEEDED FOR FRONT FRAME MOUNTED EQUIPMENT	N/C
552-032	1650MM (65 INCH) REAR FRAME OVERHANG	N/C
55W-006	FRAME OVERHANG RANGE: 61 INCH TO 70 INCH	N/C

Prepared for:
 Ryan Reed
 MISSOURI DOT
 830 MoDOT Drive
 605CO23000319
 JEFFERSON CITY, MO 65109
 Phone: (573) 751-3685

Prepared by:
 Matt Pace
 TRUCK CENTERS, INC.
 2280 FORMOSA RD.
 TROY, IL 62294
 Phone: 618-667-3454

549-002	24 INCH INTEGRAL FRONT FRAME EXTENSION	140	-20	\$4.00
AC8-99D	CALC'D BACK OF CAB TO REAR SUSP C/L (CA) : 114.57 in			
AE8-99D	CALCULATED EFFECTIVE BACK OF CAB TO REAR SUSPENSION C/L (CA) : 111.57 in			
AE4-99D	CALC'D FRAME LENGTH - OVERALL : 310.28 in			
FSS-0LH	CALCULATED FRAME SPACE LH SIDE : 32.28 in			N/C
FSS-0RH	CALCULATED FRAME SPACE RH SIDE : 62.07 in			N/C
553-001	SQUARE END OF FRAME			STD
550-001	FRONT CLOSING CROSSMEMBER			STD
559-001	STANDARD WEIGHT ENGINE CROSSMEMBER			STD
562-001	STANDARD MIDSHIP #1 CROSSMEMBER(S)			STD
572-001	STANDARD REARMOST CROSSMEMBER			STD
565-001	STANDARD SUSPENSION CROSSMEMBER			STD

Chassis Equipment

556-997	OMIT FRONT BUMPER, CUSTOMER INSTALLED SPECIAL BUMPER, DOES NOT COMPLY WITH FMCSR 393.203	-110		(\$488.00)
558-001	FRONT TOW HOOKS - FRAME MOUNTED	15		\$80.00
551-007	GRADE 8 THREADED HEX HEADED FRAME FASTENERS			STD
607-001	CLEAR FRAME RAILS FROM BACK OF CAB TO FRONT REAR SUSPENSION BRACKET, BOTH RAILS OUTBOARD			\$218.00

Fuel Tanks

204-215	50 GALLON/189 LITER SHORT RECTANGULAR ALUMINUM FUEL TANK - LH	-10		\$30.00
218-005	RECTANGULAR FUEL TANK(S)			N/C
215-005	PLAIN ALUMINUM/PAINTED STEEL FUEL/HYDRAULIC TANK(S) WITH PAINTED BANDS			STD
212-007	FUEL TANK(S) FORWARD			STD
664-001	PLAIN STEP FINISH			STD
205-001	FUEL TANK CAP(S)			STD
122-1J1	DETROIT FUEL/WATER SEPARATOR WITH WATER IN FUEL SENSOR, HAND PRIMER AND 12 VOLT PREHEATER"	-5		\$51.00
216-020	EQUIFLO INBOARD FUEL SYSTEM			STD
202-016	HIGH TEMPERATURE REINFORCED NYLON FUEL LINE			STD

Tires

093-1YU	CONTINENTAL HAU 3 WT 315/80R22.5 20 PLY RADIAL FRONT TIRES	100		\$482.00
---------	---	-----	--	----------

Prepared for:
 Ryan Reed
 MISSOURI DOT
 830 MoDOT Drive
 605CO23000319
 JEFFERSON CITY, MO 65109
 Phone: (573) 751-3685

Prepared by:
 Matt Pace
 TRUCK CENTERS, INC.
 2280 FORMOSA RD.
 TROY, IL 62294
 Phone: 618-667-3454

094-12P	CONTINENTAL HDR2+ 11R22.5 14 PLY RADIAL REAR TIRES	92	(\$412.00)
* 095-12P	CONTINENTAL HDR2+ 11R22.5 14 PLY RADIAL PUSHER/TAG TIRES	-20	\$1,230.00

Hubs

418-060	CONMET PRESET PLUS PREMIUM IRON FRONT HUBS		STD
450-060	CONMET PRESET PLUS PREMIUM IRON REAR HUBS		STD
449-060	CONMET PRESET PLUS PREMIUM IRON PUSHER/TAG HUBS		N/C

Wheels

502-579	MAXION WHEELS 10041 22.5X9.00 10-HUB PILOT 5.25 INSET 5-HAND STEEL DISC FRONT WHEELS	66	\$204.00
505-545	MAXION WHEELS 90260 22.5X8.25 10-HUB PILOT 2-HAND HD STEEL DISC REAR WHEELS	80	(\$32.00)
* 509-428	ACCURIDE 28828 22.5X8.25 10-HUB PILOT 2-HAND HD STEEL DISC PUSHER/TAG WHEELS	26	\$390.00
496-011	FRONT WHEEL MOUNTING NUTS		STD
497-011	REAR WHEEL MOUNTING NUTS		STD
495-011	PUSHER/TAG WHEEL MTG NUTS		N/C
498-011	NYLON WHEEL GUARDS FRONT AND REAR ALL INTERFACES		\$32.00

Cab Exterior

829-1A5	108 INCH BBC FLAT ROOF ALUMINUM CONVENTIONAL CAB		STD
650-008	AIR CAB MOUNTING		STD
648-002	NONREMOVABLE BUGSCREEN MOUNTED BEHIND GRILLE		STD
667-037	SHORT FENDER WITH MUDFLAP		\$141.00
754-017	BOLT-ON MOLDED FLEXIBLE FENDER EXTENSIONS	10	\$115.00
678-001	LH AND RH GRAB HANDLES		STD
646-041	STATIONARY BLACK GRILLE		STD
65X-004	BLACK HOOD MOUNTED AIR INTAKE GRILLE		STD
644-004	FIBERGLASS HOOD		STD
690-017	HOOD LINER, ADDED FIREWALL AND FLOOR HEAT INSULATION	5	\$186.00
727-1AH	SINGLE 14 INCH ROUND POLISHED AIR HORN ROOF MOUNTED		STD
726-002	DUAL ELECTRIC HORNS		\$14.00
728-001	SINGLE HORN SHIELD		STD
575-001	REAR LICENSE PLATE MOUNT END OF FRAME		STD

Prepared for:
 Ryan Reed
 MISSOURI DOT
 830 MoDOT Drive
 605CO23000319
 JEFFERSON CITY, MO 65109
 Phone: (573) 751-3685

Prepared by:
 Matt Pace
 TRUCK CENTERS, INC.
 2280 FORMOSA RD.
 TROY, IL 62294
 Phone: 618-667-3454

312-068	HALOGEN COMPOSITE HEADLAMPS WITH BLACK BEZELS	STD
302-047	LED AERODYNAMIC MARKER LIGHTS	\$34.00
311-025	HEADLIGHTS ON WITH WIPERS, WITH LOW BEAM DAYTIME RUNNING LIGHTS	\$21.00
294-001	INTEGRAL STOP/TAIL/BACKUP LIGHTS	STD
300-015	STANDARD FRONT TURN SIGNAL LAMPS	STD
744-1BG	DUAL WEST COAST MOLDED-IN COLOR HEATED MIRRORS	\$93.00
797-001	DOOR MOUNTED MIRRORS	STD
796-001	102 INCH EQUIPMENT WIDTH	STD
743-1AP	LH AND RH 8 INCH MOLDED-IN COLOR CONVEX MIRRORS MOUNTED UNDER PRIMARY MIRRORS	N/C
729-001	STANDARD SIDE/REAR REFLECTORS	STD
275-061	PARK BRAKE REMINDER WARNING SYSTEM	\$3.00
768-043	63X14 INCH TINTED REAR WINDOW	STD
661-003	TINTED DOOR GLASS LH AND RH WITH TINTED NON-OPERATING WING WINDOWS	(\$117.00)
654-003	MANUAL DOOR WINDOW REGULATORS	N/C
663-029	1-PIECE BONDED HEATED WIPER PARK SOLAR GREEN GLASS WINDSHIELD	\$423.00
659-006	8 LITER (2 GAL) WINDSHIELD WASHER RESERVOIR, CAB MOUNTED, WITH FLUID LEVEL INDICATOR	\$15.00

Cab Interior

707-1AK	OPAL GRAY VINYL INTERIOR	N/C
706-013	MOLDED PLASTIC DOOR PANEL	STD
708-013	MOLDED PLASTIC DOOR PANEL	STD
772-006	BLACK MATS WITH SINGLE INSULATION	STD
785-004	DASH MOUNTED ASH TRAY(S) WITHOUT LIGHTER	STD
691-008	FORWARD ROOF MOUNTED CONSOLE WITH UPPER STORAGE COMPARTMENTS WITHOUT NETTING	STD
694-010	IN DASH STORAGE BIN	STD
742-007	(2) CUP HOLDERS LH AND RH DASH	STD
680-006	GRAY/CHARCOAL FLAT DASH	STD
860-004	SMART SWITCH EXPANSION MODULE	\$196.00
700-002	HEATER, DEFROSTER AND AIR CONDITIONER	STD
701-001	STANDARD HVAC DUCTING	STD
703-005	MAIN HVAC CONTROLS WITH RECIRCULATION SWITCH	STD
170-015	STANDARD HEATER PLUMBING	STD

Prepared for:
 Ryan Reed
 MISSOURI DOT
 830 MoDOT Drive
 605CO23000319
 JEFFERSON CITY, MO 65109
 Phone: (573) 751-3685

Prepared by:
 Matt Pace
 TRUCK CENTERS, INC.
 2280 FORMOSA RD.
 TROY, IL 62294
 Phone: 618-667-3454

130-041	VALEO HEAVY DUTY A/C REFRIGERANT COMPRESSOR			STD
702-002	BINARY CONTROL, R-134A			STD
739-034	PREMIUM INSULATION			\$145.00
285-013	SOLID-STATE CIRCUIT PROTECTION AND FUSES			STD
280-007	12V NEGATIVE GROUND ELECTRICAL SYSTEM			STD
324-011	DOME DOOR ACTIVATED LH AND RH, DUAL READING LIGHTS, FORWARD CAB ROOF			STD
657-001	DOOR LOCKS AND IGNITION SWITCH KEYED THE SAME			STD
78G-004	KEY QUANTITY OF 4			\$18.00
655-001	CAB DOOR LATCHES WITH MANUAL DOOR LOCKS			N/C
284-045	(2) 12 VOLT POWER RECEPTACLES MOUNTED IN DASH			\$1.00
756-338	BASIC ISRINGHAUSEN HIGH BACK AIR SUSPENSION DRIVERS SEAT WITH MECHANICAL LUMBAR AND INTEGRATED CUSHION EXTENSION	30		\$167.00
760-338	BASIC ISRINGHAUSEN HIGH BACK AIR SUSPENSION PASSENGER SEAT WITH MECHANICAL LUMBAR AND INTEGRATED CUSHION EXTENSION	25	10	\$255.00
759-006	DUAL DRIVER SEAT ARMRESTS AND INBOARD PASSENGER SEAT ARMREST	6		\$104.00
711-004	LH AND RH INTEGRAL DOOR PANEL ARMRESTS			STD
758-014	BLACK CORDURA PLUS CLOTH DRIVER SEAT COVER			\$2.00
761-014	BLACK CORDURA PLUS CLOTH PASSENGER SEAT COVER			\$4.00
763-102	HIGH VISIBILITY ORANGE SEAT BELTS			\$13.00
532-002	ADJUSTABLE TILT AND TELESCOPING STEERING COLUMN	10		\$478.00
540-015	4-SPOKE 18 INCH (450MM) STEERING WHEEL			STD
765-002	DRIVER AND PASSENGER INTERIOR SUN VISORS			STD

Instruments & Controls

732-004	GRAY DRIVER INSTRUMENT PANEL			STD
734-004	GRAY CENTER INSTRUMENT PANEL			STD
87L-001	ENGINE REMOTE INTERFACE WITH PARK BRAKE INTERLOCK			N/C
870-001	BLACK GAUGE BEZELS			N/C
486-001	LOW AIR PRESSURE INDICATOR LIGHT AND AUDIBLE ALARM			STD

Prepared for:
 Ryan Reed
 MISSOURI DOT
 830 MoDOT Drive
 605CO23000319
 JEFFERSON CITY, MO 65109
 Phone: (573) 751-3685

Prepared by:
 Matt Pace
 TRUCK CENTERS, INC.
 2280 FORMOSA RD.
 TROY, IL 62294
 Phone: 618-667-3454

840-002	2 INCH PRIMARY AND SECONDARY AIR PRESSURE GAUGES		STD
198-025	INTAKE MOUNTED AIR RESTRICTION INDICATOR WITHOUT GRADUATIONS		STD
721-001	97 DB BACKUP ALARM	3	\$47.00
149-013	ELECTRONIC CRUISE CONTROL WITH SWITCHES IN LH SWITCH PANEL		STD
156-007	KEY OPERATED IGNITION SWITCH AND INTEGRAL START POSITION; 4 POSITION OFF/RUN/START/ACCESSORY		STD
811-042	ICU3S, 132X48 DISPLAY WITH DIAGNOSTICS, 28 LED WARNING LAMPS AND DATA LINKED		STD
160-038	HEAVY DUTY ONBOARD DIAGNOSTICS INTERFACE CONNECTOR LOCATED BELOW LH DASH		STD
844-001	2 INCH ELECTRIC FUEL GAUGE		STD
148-073	ENGINE REMOTE INTERFACE FOR REMOTE THROTTLE		\$110.00
163-001	ENGINE REMOTE INTERFACE CONNECTOR AT BACK OF CAB		N/C
856-001	ELECTRICAL ENGINE COOLANT TEMPERATURE GAUGE		STD
864-001	2 INCH TRANSMISSION OIL TEMPERATURE GAUGE		STD
830-017	ENGINE AND TRIP HOUR METERS INTEGRAL WITHIN DRIVER DISPLAY		STD
33A-051	WIRING PROVISION FOR CUSTOMER FURNISHED ROOF MOUNTED LIGHTBAR WITH 2 WIRES HANDLE UP TO 30 AMPS OF CURRENT		\$212.00
372-035	(1) DASH MOUNTED PTO SWITCH WITH INDICATOR LAMP	10	\$69.00
852-002	ELECTRIC ENGINE OIL PRESSURE GAUGE		STD
679-001	OVERHEAD INSTRUMENT PANEL		N/C
746-137	AM/FM/WB WORLD TUNER RADIO WITH BLUETOOTH, USB AND AUXILIARY INPUTS, J1939	10	\$490.00
747-001	DASH MOUNTED RADIO		N/C
750-002	(2) RADIO SPEAKERS IN CAB		N/C
753-001	AM/FM ANTENNA MOUNTED ON FORWARD LH ROOF		\$23.00
748-006	POWER AND GROUND WIRING PROVISION OVERHEAD		\$9.00
749-016	CB WIRING ONLY TO ROOF/OVERHEAD CONSOLE; NO MOUNTING PROVISION		\$32.00
810-027	ELECTRONIC MPH SPEEDOMETER WITH SECONDARY KPH SCALE, WITHOUT ODOMETER		STD

Prepared for:
 Ryan Reed
 MISSOURI DOT
 830 MoDOT Drive
 605CO23000319
 JEFFERSON CITY, MO 65109
 Phone: (573) 751-3685

Prepared by:
 Matt Pace
 TRUCK CENTERS, INC.
 2280 FORMOSA RD.
 TROY, IL 62294
 Phone: 618-667-3454

817-001	STANDARD VEHICLE SPEED SENSOR	STD
812-001	ELECTRONIC 3000 RPM TACHOMETER	STD
162-011	IDLE LIMITER, ELECTRONIC ENGINE	N/C
329-092	(8) IGN CONTROLLED EXTRA SWITCHES WITH IND LIGHTS WIRED TO POWER DIST BOX WITH RELAYS PROVIDING 20 AMPS PER CIRCUIT TO JUNCTION BLOCK AND 1 CIRCUIT AT 30 AMPS	\$438.00
81Y-001	PRE-TRIP LAMP INSPECTION, ALL OUTPUTS FLASH, WITH SMART SWITCH	\$12.00
482-001	BW TRACTOR PROTECTION VALVE	N/C
883-001	TRAILER HAND CONTROL BRAKE VALVE	N/C
836-015	DIGITAL VOLTAGE DISPLAY INTEGRAL WITH DRIVER DISPLAY	STD
660-025	SINGLE ELECTRIC WINDSHIELD WIPER MOTOR WITH DELAY PROGRAMMED TO SLOWEST SPEED WITH PARK BRAKE SET	\$19.00
304-039	MARKER LIGHT SWITCH INTEGRAL WITH HEADLIGHT SWITCH AND DUAL CONNECTORS AND SWITCH FOR CUSTOMER FURNISHED SNOW PLOW LIGHTS, LOW BEAMS OFF WITH HIGH BEAMS	\$214.00
882-021	TWO VALVE PARKING BRAKE SYSTEM WITH DASH VALVE CONTROL AUTONEUTRAL AND WARNING INDICATOR	\$13.00
299-013	SELF CANCELING TURN SIGNAL SWITCH WITH DIMMER, WASHER/WIPER AND HAZARD IN HANDLE	STD
298-039	INTEGRAL ELECTRONIC TURN SIGNAL FLASHER WITH HAZARD LAMPS OVERRIDING STOP LAMPS	STD

Design

065-000	PAINT: ONE SOLID COLOR	STD
---------	------------------------	-----

Color

980-5F6	CAB COLOR A: L0006EY WHITE ELITE EY	STD
986-020	BLACK, HIGH SOLIDS POLYURETHANE CHASSIS PAINT	STD
962-972	POWDER WHITE (N0006EA) FRONT WHEELS/RIMS (PKWHT21, TKWHT21, W, TW)	STD
966-972	POWDER WHITE (N0006EA) REAR WHEELS/RIMS (PKWHT21, TKWHT21, W, TW)	STD
96E-972	POWDER WHITE (N0006EA) PUSHER/TAG WHEELS/RIMS (PKWHT21, TKWHT21, W, TW)	N/C
963-003	STANDARD E COAT/UNDERCOATING	STD

Certification / Compliance

996-001	U.S. FMVSS CERTIFICATION, EXCEPT SALES CABS AND GLIDER KITS	STD
---------	---	-----

Prepared for:
 Ryan Reed
 MISSOURI DOT
 830 MoDOT Drive
 605CO23000319
 JEFFERSON CITY, MO 65109
 Phone: (573) 751-3685

Prepared by:
 Matt Pace
 TRUCK CENTERS, INC.
 2280 FORMOSA RD.
 TROY, IL 62294
 Phone: 618-667-3454

Secondary Factory Options

	998-001	CORPORATE PDI CENTER IN-SERVICE ONLY	N/C
N	999-034	DEALER ADVISED AND ACCEPTS TERMS OF PIL#395; SPEED OF LOADED VEHICLE MUST BE LIMITED TO 5 MPH MAXIMUM WHEN LIFTABLE AXLE IS RAISED	N/C

Sales Programs

NO SALES PROGRAMS HAVE BEEN SELECTED

TOTAL VEHICLE SUMMARY

Adjusted List Price

Adjusted List Price ** \$156,555.00

Weight Summary

	Weight Front	Weight Rear	Total Weight
Factory Weight [†]	8345 lbs	5624 lbs	13969 lbs
Total Weight [†]	8345 lbs	5624 lbs	13969 lbs

ITEMS NOT INCLUDED IN ADJUSTED LIST PRICE

Other Factory Charges

	PMV-021	GHG21 ENHANCEMENT PRICE	\$510.00
	RAG-020	CUMMINS TARIFF CHARGE - \$205	\$205.00
N	RAT-24Y	MY24 ESCALATOR	\$1,500.00
	RFY-022	FRONT TIRE SURCHARGE	\$60.00
	RFU-022	REAR TIRE SURCHARGE	\$120.00
	RFZ-024	MY24/CY23 PRICING SURCHARGE	\$3,750.00
	P73-2FT	STANDARD DESTINATION CHARGE	\$3,375.00

Prepared for:
Ryan Reed
MISSOURI DOT
830 MoDOT Drive
605CO23000319
JEFFERSON CITY, MO 65109
Phone: (573) 751-3685

Prepared by:
Matt Pace
TRUCK CENTERS, INC.
2280 FORMOSA RD.
TROY, IL 62294
Phone: 618-667-3454

Extended Warranty

WAG-038	TOWING: 1 YEAR/UNLIMITED MILES/KM EXTENDED TOWING COVERAGE \$1200 CAP FEX APPLIES	\$405.00
---------	--	----------

Currency Exchange Rate	1.0000
------------------------	--------

Total Extended Warranty (Local Currency)	\$405.00
--	----------

(+) Weights shown are estimates only.

If weight is critical, contact Customer Application Engineering.

(**) Prices shown do not include taxes, fees, etc... "Net Equipment Selling Price" is located on the Quotation Details Proposal Report.

(***) All cost increases for major components (Engines, Transmissions, Axles, Front and Rear Tires) and government mandated requirements, tariffs, and raw material surcharges will be passed through and added to factory invoices.

Prepared for:
 Ryan Reed
 MISSOURI DOT
 830 MoDOT Drive
 605CO23000319
 JEFFERSON CITY, MO 65109
 Phone: (573) 751-3685

Prepared by:
 Matt Pace
 TRUCK CENTERS, INC.
 2280 FORMOSA RD.
 TROY, IL 62294
 Phone: 618-667-3454

D I M E N S I O N S

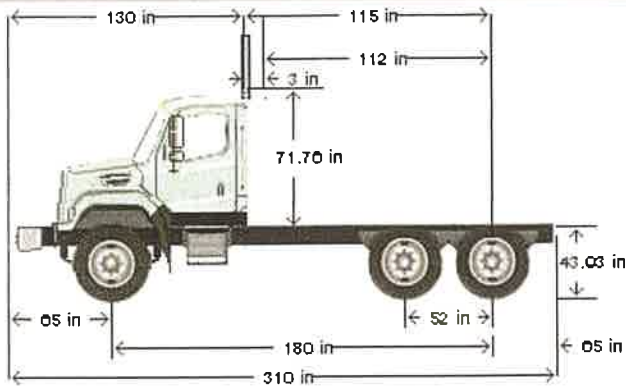

VEHICLE SPECIFICATIONS SUMMARY - DIMENSIONS

Wheelbase (545)	4575MM (180 INCH) WHEELBASE
Rear Frame Overhang (552)	1650MM (65 INCH) REAR FRAME OVERHANG
Fifth Wheel (578)	NO FIFTH WHEEL
Mounting Location (577)	NO FIFTH WHEEL LOCATION
Maximum Forward Position (in)	0
Maximum Rearward Position (in)	0
Amount of Slide Travel (in)	0
Slide Increment (in)	0
Desired Slide Position (in)	0.0
Cab Size (829)	108 INCH BBC FLAT ROOF ALUMINUM CONVENTIONAL CAB
Sleeper (682)	NO SLEEPER BOX/SLEEPERCAB
Exhaust System (016)	RH OUTBOARD UNDER STEP MOUNTED HORIZONTAL AFTERTREATMENT SYSTEM ASSEMBLY WITH RH B-PILLAR MOUNTED VERTICAL TAILPIPE

TABLE SUMMARY - DIMENSIONS

Prepared for:
 Ryan Reed
 MISSOURI DOT
 830 MoDOT Drive
 605CO23000319
 JEFFERSON CITY, MO 65109
 Phone: (573) 751-3685

Prepared by:
 Matt Pace
 TRUCK CENTERS, INC.
 2280 FORMOSA RD.
 TROY, IL 62294
 Phone: 618-667-3454

Dimensions	Inches
Bumper to Back of Cab (BBC)	130.1
Bumper to Centerline of Front Axle (BA)	64.6
Front Axle to Back of Cab (AC)	65.6
Min. Cab to Body Clearance (CB)	3.0
Back of Cab to Centerline of Rear Axle(s) (CA)	114.6
Effective Back of Cab to Centerline of Rear Axle(s) (Effective CA)	111.6
Back of Cab Protrusions (Exhaust/Intake) (CP)	2.0
Back of Cab Protrusions (Side Extenders/Trim Tab) (CP)	0.0
Back of Cab Protrusions (CNG Tank)	0.0
Back of Cab Clearance (CL)	3.0
Back of Cab to End of Frame	179.6
Cab Height (CH)	71.8
Wheelbase (WB)	180.1
Frame Overhang (OH)	65.0
Overall Frame Length	310.3
Overall Length (OAL)	309.7
Rear Axle Spacing	0.0
Pusher/Tag Axle Spacing	52.0
Unladen Frame Height at Centerline of Rear Axle	43.9

Performance calculations are estimates only. If performance calculations are critical, please contact Customer Application Engineering.