

## **1.00.000 Policies And Procedures For Retail Water Service**

[1.01.000 Mission Statement](#)

[1.02.000 Application For Water Service](#)

[1.03.000 Termination Of Service](#)

[1.04.000 Billing And Payment Of Bills](#)

[1.05.000 Rates, Charges, And Fees](#)

[1.06.000 Service Connections](#)

[1.07.000 Multiple Units](#)

[1.08.000 Fire Hydrants And Fire Lines](#)

[1.09.000 Water Main Extensions](#)

[1.10.000 Upgrading Size Of Connections](#)

[1.11.000 All Other Services](#)

[1.12.000 General Provisions And Obligations](#)

[1.13.000 Control Of Backflow And Cross Connections](#)

[1.14.000 Well Drilling Policy](#)

[01.15.000 Bulk Water Sales](#)

[01.16.000 Water Design Standards](#)

[01.17.000 Penalties And Violations](#)

[01.20.000 Appendix A Schedule Of Water Rates, Fees, And Charges](#)

[01.21.000 Appendix B Acknowledgement Of Water Supply](#)

## **BIG PLAINS WATER SPECIAL SERVICE DISTRICT POLICIES AND PROCEDURES FOR RETAIL WATER SERVICE**

HISTORY

*Amended by Ord. on 12/28/2020*

### **1.01.000 Mission Statement**

To Provide Safe and Clean Drinking Water to the District Residents as well as Fire Protection that Meets State Standards.

### **1.02.000 Application For Water Service**

[1.02.010 New Connections For Water Service](#)

[1.02.020 Transfer Of An Existing Connection To A New Applicant](#)

[1.02.030 Temporary Retail Connections](#)

[1.02.040 Procedures For Obtaining Water Service For Development Projects](#)

[1.02.050 Procedures For Other Work On Water System](#)

### **1.02.010 New Connections For Water Service**

- A. Applicants desiring a connection for property located within the District shall notify the District requesting that the District provide the required retail water service. New connections may be installed prior to an approved culinary use. However, it will be locked and unusable until such time a building permit has been issued by the Town of Apple Valley. As an exception, water meters may be installed for agricultural use only. It may not be connected to any structure or be used as culinary water. Any unauthorized use will be subject to lockout. The installation will require the impact fee, connection fee and appropriate municipal category water right provided by applicant by conveyance. If the agricultural connection is changed to culinary use and the property is under new ownership, the connection will be subject to the impact fee less any standby credits. The District will then follow its procedures for obtaining water service. The applicants shall bear the cost of all expenses associated with providing the retail water service. If

providing service by the District requires a mainline extension, the applicant will follow the procedures starting with 1.02.040 Procedures for Obtaining Water Services for Development Projects.

- B. Upon approval of the new water connection and payment of required deposit, the applicant shall engage at their own expense a licensed and insured contractor approved by the Water Superintendent for the excavation of the water main. The contractor shall schedule the excavation at a time when the Water Superintendent is available to supervise the excavation. Contractor shall obtain an Encroachment Permit from the Town, if required. Upon excavation of the water main, the Water Superintendent shall then install the service line and required water meter. After the installation of the water meter, the contractor shall then replace excavated materials, and repair the impacted area to the condition prior to excavation. This includes new road base or asphalt as required by Apple Valley Town Standards.
- C. Unless waived by the District for good cause applicants desiring a connection for property not included within the existing boundaries of the District shall petition to annex their lands into the District before their application will be processed. The petition shall include a legal description of the property and reasonable evidence that the petitioner is the owner of the property to be annexed or is the lawful agent of the owner. In addition, if the property is located within the legal boundaries of an incorporated city, the application shall also comply with the procedure in Section A.
- D. All applicants shall sign a Water Application and Agreement. Such application shall include the location of the desired water service, the name of the applicant, the date of application, proof of ownership of the property, and the basic terms and conditions with which the applicant shall be required to comply to receive water service. Such terms and conditions shall require the applicant to:
  - 1. Pay the current connection deposit as established by the District's Board of Trustees. After completion of the connection, the District will provide applicant an itemized billing of time and materials for the connection, and shall either refund the unused portion of the deposit or bill the applicant for the balance. Refund of deposit will be mailed within 30 days of completion. If a balance remains, that amount shall be paid within 30 days of completion or the meter is subject to lockout until payment in full is received. Connection certificates issued and agreements providing for connections executed prior to the effective date of these rules and regulations shall be honored.
  - 2. All new applicants shall provide to the District the applicant's social security number and pay to the District a \$100 deposit, which, at the option and request of the applicant, may be credited to the applicant's account after one year, provided that the applicant's account has not been delinquent at any time during the one-year time period. Should the applicant fail to request that the deposit be credited to their account after such time, the District shall retain the deposit until either party terminates service. Upon termination, the District will return the deposit to the applicant, less any amounts still owing to the District. Should an applicant choose not to provide their social security number; the applicant shall pay a \$500 deposit, which will be retained by the District until either party terminates service. Upon termination, the District will return the deposit to the applicant, less any amounts still owing to the District. Existing customers shall not be required to provide the District with their social security number, unless their accounts have ever been delinquent for more than ninety (90) days.
  - 3. Convey to the District, in a form or manner approved by the District, an existing water right in a quantity sufficient to allow the District to meet the use applied for by the applicant. For a single-family residential connection with outside irrigation not exceeding one acre, the quantity of water right to be conveyed is 1.0-acre foot. The requirement for other applications, such as commercial or larger acreage, shall be determined on a case-by-case basis. The conveyance to the District and the District's obligation to service the

applicant is conditioned upon approval by the State Engineer of a change application filed by the District to change the nature and place of use and the point of diversion of the conveyed water right to that consistent with the requested service. Any reduction by the State Engineer in the quantity of water approved as a result of change of nature of use or forfeiture shall be the responsibility of the applicant.

4. Pay for all sums of water usage and service charges at the rates lawfully set from time to time by the District's Board of Trustees. The District shall impose a five percent (5%) finance charge, applied monthly to all delinquent accounts.
  5. Abide and obey all rules and regulations then in effect and thereafter adopted by the District.
  6. Pay all water and service charges by the last day of the month the statement is prepared. Failure to pay said charges within 30 days of statement date will result in the account being declared delinquent and the water service terminated upon proper notice. Water service shall be restored upon payment of all delinquent amounts plus a reasonable service restoration charge.
  7. Pay any interest, collection charge, and restoration fee set forth in these rules and regulations.
  8. Pay all costs, including attorney's fees, incurred by the District through its efforts to collect any delinquency or to enforce these rules and regulations.
  9. Acknowledge that the service connection and all of its parts and materials from the water main to the point of connection to the line stubbed from the building, said point of connection being immediately downstream of the meter box, shall be the property of the District.
  10. Acknowledge that the District reserves the right at any time, without notice, to shut off or curtail water service, in the event of a water scarcity, to facilitate repairing or maintenance of the District's water system, or to protect the District's water system and supply from contamination which could endanger the public health.
  11. Identify a relative by name and address, not living with the applicant.
  12. Notify the District of any cross-connection, backflow incident, or other condition within the customer's system which may put the District's system and/or water supply at risk for contamination. Notification must occur as soon as possible, but no later than 24 hours upon learning about such conditions.
  13. Acknowledge that the customer shall be responsible for installing and maintaining a thermal expansion chamber and a pressure reducing valve on the cold water line feeding the customer's water heater, and that any damage which may occur as a result of a missing or faulty thermal expansion chamber or pressure reducing valve shall be the responsibility of the customer. Neither the chamber nor the valve shall be removed except to necessitate a replacement or repair.
- E. The District shall maintain a list of customers with unpaid water bills. Applications for water service from previous customers with unpaid balances shall not be processed until the unpaid balances together with interest are paid.
- F. Upon proper execution of the annexation petition, if applicable, signing of the Water Application and Agreement, payment of the current connection fee, conveyance of the required water rights, plus any other charges or fees that are determined to be due and the District's determination that water and facilities are available for service at such location, the applicant shall be accepted as a retail customer of the District.

### **1.02.020 Transfer Of An Existing Connection To A New Applicant**

- A. An existing connection may be transferred to a new applicant upon the same terms and conditions as required for a new connection with the exception that in place of a connection fee, the new applicant must demonstrate proof of purchase or lease. Proof may be demonstrated by a deed or lease for the property involved, or by such other evidence as the District may deem sufficient.
- B. If the new applicant is a renter or lessee, the property owner must also sign a Water Application and Agreement. The property owner must return the Water Application and Agreement within ten (10) days after the renter or lessee has signed an agreement if a local resident. Out of town property owners must return the application within ten (10) days. If the property owner does not return the application within the specified number of days, water service shall be terminated at the service address until the application is received. Payment of the bill shall be the responsibility of the property owner. If requested by the property owner, a copy of the bill will be mailed to the renter or lessee.
- C. If the renter or lessee operates a business on the property, the renter or lessee shall remit a refundable deposit, the amount of which shall be established from time to time by the Board of Trustees.

### **1.02.030 Temporary Retail Connections**

- A. Applicants for a connection to provide water on a temporary basis (for purposes such as construction) shall sign a Temporary Water Use Agreement which shall include the information, terms and conditions included in the regular Water Application and Agreement and also the estimated amount of water usage. The applicant shall also pay a connection fee which shall consist of the estimated charge for actual services rendered and non-recoverable materials used in making the connection, plus a reasonable service charge for the processing of the application.
- B. Upon approval of the application, payment of the required fees and installation of the service connections by the District, the applicant may connect into the District's system through the service connection provided. The connection shall be made according to requirements and terms which the District may consider appropriate to monitor the safety, health and integrity of its water and its facilities. The water provided shall be used only for the purpose outlined in the application; use in any other manner may constitute grounds for cancellation of service.
- C. All damage to the service connection, meter, and excess water usage shall be billed to the applicant and payable upon the terms and conditions of the Water Application and Agreement.
- D. The water rates for temporary retail service shall be the District's retail rate plus ten percent (10%). In addition, the applicant shall pay a \$25 connection fee.

### **1.02.040 Procedures For Obtaining Water Service For Development Projects**

- A. Prior to zone change or preliminary plat:
  - 1. The Developer will meet with the Water Superintendent to discuss available services. If none are available, options to obtain services will be discussed. The Developer must provide proof of ownership of municipal category water rights sufficient for the project, prior to the issuance of a preliminary will serve letter. A preliminary will serve letter will outline requirements needed to hookup to the District system and any and all water infrastructure needed to be supplied by the developer to serve the project. The applicant assumes the entire risk of water availability for the project, subdivision, or development.

2. A will serve letter will only be issued along with an application for a building permit if water services are available.
3. A letter with results will be given to the Developer to provide to the Town of Apple Valley Planning and Zoning Board.
4. An Acknowledgement of Water Form (Appendix B) must be signed and submitted with the preliminary plat application with the Town of Apple Valley. Said acknowledgement form outlines that the District does not guarantee that water will be available for the project, subdivision or development when applied for.
5. No District officer or employee is authorized to issue a will serve letter. The letter must be provided by the District Engineer. Any letter issued in conflict of this section shall be null and void.

B. Following approval of the preliminary plat:

1. The Developer's engineer will provide proposed construction plans as per District Design Standards to the Apple Valley Joint Utilities Commission (JUC) committee, and to a District representative.
2. The District Engineer will then review, redline and return plans at the new JUC meeting to the Developers. The Developer's engineer will make the requested corrections on the Master set of construction plans.
3. The Developer will provide a set of the final completed master construction plans for a final review by the District Engineer or District Staff.
4. If plans are approved, the District representative will sign-off on the master set of construction plans.
5. Developer will deed the municipal category water rights over to the District, according to the will serve letter received, at the time of recording the final plat. If the project is to be completed in phases, at the option of the District, water rights may be deeded according to each phase as it is approved.

C. A Pre-Construction meeting will then be held by the Apple Valley Public Works Consultant. Contractor shall provide a copy of his Utah State License, evidence of the Contractor's insurance and proof of bonding, if required. The required amount of the bond shall be determined by the District Engineer or Inspector based on the scope and exposure of the project. The Contractor may then start construction and arrange all required inspections with the District Inspector as construction proceeds and finishes.

1. Upon completion of the work, the Contractor shall provide the District with as-built plans, both in print and in electronic format, and proof of all soils testing that was completed during construction.
2. Upon completion, the Developer is to provide a one (1) year warranty bond of 10% of the construction cost, or pay the bond amount to the District. The bond amount will then be released back to the Developer after the one-year warranty period is over and any needed warranty repairs have been made.
3. The District transmits one executed copy of the Water Extension Agreement to the Developer and one copy to the District Engineer. All District engineering review fees and all inspection fees are to be paid by the Developer.

**1.02.050 Procedures For Other Work On Water System**

- A. Prior to work performed on the water system, all procedures in Section 1.02.040 Procedures for Obtaining Water Service for Development Projects must be followed.
- B. Contractor shall provide a copy of his Utah State License, evidence of the contractor's insurance, and a copy of an encroachment surety bond. The required amount of the bond shall be determined by the district Engineer or Inspector based on the scope and exposure of the project.
- C. District Engineer or Inspector will provide the Contractor written authorization to perform work as outlined in the proposal.
- D. District Inspector makes visits to the site to observe the Contractor's work and to guard the District against deficiencies in the work. The Contractor must follow all directions from the District Inspector.

### **1.03.000 Termination Of Service**

- A. When termination of service is desired, the water user shall notify the District and request the preparation of a final bill.
- B. If the water user is a renter or lessee, upon payment of the final bill, the District shall refund any previously received deposit. Otherwise, the deposit shall be applied towards the outstanding bill.
- C. If the deposit is more than required to cover the outstanding balance for water service, the outstanding balance shall be deducted from the deposit and the remainder refunded to the customer. A reasonable attempt shall be made to obtain a forwarding address to refund any remaining deposit. Deposits not refunded or claimed after one year shall be forwarded to the State of Utah.
- D. The District may, for just cause and after due notice and an opportunity to be heard before the Chairman, terminate the water service of any customer.
- E. If any building permit has been revoked by the Town of Apple Valley, the District will terminate service and remove the water meter.

### **1.04.000 Billing And Payment Of Bills**

#### **1.04.010 Meter Reading**

#### **1.04.020 Payment Of Bills**

#### **1.04.030 Disputed Bills**

### **1.04.010 Meter Reading**

- A. To the extent possible, water meters shall be read each month, and corresponding bills shall be sent to customers for that month's water use. However, this interval may be varied under special circumstances or situations.
- B. Large water users, such as apartment complexes and some types of businesses, shall have their own meters read every month.
- C. An initial reading shall be made when water service is commenced and a final reading shall be made when service is terminated or transferred to a new customer.
- D. Except as set forth in Section B, the District may elect not to read meters from December through February. During this time, estimated bills may be sent based on the rates and estimated usage as set from time to time by the Board. When the meters are buried by snow or other obstacles, or in other circumstances when the meter is inaccessible or otherwise unreadable, the District also may estimate the bill, taking into account prior years' water use, the season, and the prevailing weather patterns and water use. Any overcharge or undercharge resulting from

estimating water usage shall be equalized when the meter is next read and a billing thereon issued.

- E. Except when water usage is estimated, the water bill shall give a statement of the current and past meter readings and the current water consumption.

#### **1.04.020 Payment Of Bills**

- A. A bill shall be due and payable by the last day of the month the statement is prepared.
- B. A bill that is not paid by its statement due date shall be considered delinquent, and shall incur an interest charge of 5% per month on the delinquent balance. In addition, legal action may be taken to collect the amount due the District.
- C. A bill which remains unpaid for more than 30 days after the statement date shall be sufficient grounds for termination of the water service.
- D. If a bill remains unpaid for more than 30 days after the statement date, a notice will be sent to the customer. The notice may or may not be contained in or printed on a customer's bill. The notice shall state that the bill is delinquent and that unless other arrangements are made with the District Staff, the outstanding balance, and interest must be paid by the date specified in the delinquent notice (generally 15 days if mailed, 24 hours posted on the door), otherwise the water service will be terminated.
  - 1. If after the specified date the bill remains unpaid, a written notice shall be hand delivered to the service address. If no one is home, the notice shall be placed in some conspicuous place. The notice shall state that unless the account, interest charge, and a \$5.00 late notice fee are paid or other arrangements made with the District Staff within 24 hours, water service will be terminated.
  - 2. If the customer pays the bill, interest charge, and late notice fee in full, the account will be cleared, and revert back to normal status.
  - 3. If the account remains unpaid or other arrangements for payment have not been made by the customer with the District Staff, the water service shall be terminated the morning of the date specified on the notice. Water service shall not be resumed until the delinquent bill, the interest charge, the \$5.00 late notice fee, and the \$50.00 service restoration fee have all been paid. The District shall have a full twenty-four (24) hours to restore the water service after payment has been made.
- E. If a customer calls to make payment arrangements with District Staff, the reason for the request must be unexpected financial hardships. Payment plans should only be allowed in extreme cases. The District Staff may approve up to a 3-month payment plan for accounts with an outstanding balance less than \$500.00. Any plan for a balance greater than \$500.00 must be approved by the District Chairman. Any scheduled payment not made when due will result in immediate termination of service without notice, in which case all outstanding amounts must be paid in full before service is restored.
- F. If the District has terminated water service at any location for any reason, and if a customer or owner restores service at such location through the District's system in any way without remedying the cause of such termination, such customer shall be assessed three times the normal restoration service fee, plus the cost of restoring the connection to its normal operational status. If anyone takes, uses, distributes, or transports water owned by the District without the District's permission, that person shall pay to the District the full cost or value of the water, whichever is greater, and a fee of \$100.00.
- G. If a customer issues any check, money order, or other instrument for payment of a water bill which is not honored upon presentment or which was returned to the District unpaid for any

reason, the District may elect to pursue, without waiving any other remedy, claim, or cause of action, those remedies set forth in the Utah Dishonored Instruments Act, Utah Code Ann. Section 7-15-1 et seq. The District also may elect to give notice of a water service Termination date, and in the that event, service shall be terminated without further notice.

- H. If, after at least one year of uninterrupted service, a retail customer is not then in arrears or otherwise in default, the customer may request the District to average the customer's bill into equal monthly payments. at the end of each year, the customer's usage will be reviewed, and the equal monthly payment adjusted, if necessary. Enrollments for this plan will be open once per year.
- I. The District shall accept the following methods of payment for retail customers' payments on account: Check; cash; cashier's check; money order; Automated Clearing House; credit card; or check-by-phone payments made through a third party designated by the District.

#### J. Security Deposits

1. A security deposit of \$100.00 will be charged to all customers. After one year, customers may request deposit to be credited to their account, provided the account has not been delinquent at any time during the one-year period.
2. A security deposit of \$100.00 will be charged to any customer who is on the District's "red tag" (delinquent) list at least three times or more in any twelve-month period. The deposit shall be paid in cash or in immediately available funds, and it shall be tendered to the District in full before service will be restored.

#### K. Payment of Standby Fees

1. Customers that are paying standby fees also receive the additional benefit of a waiver of normal impact fees. Customers in the Standby program who fail to stay current on their standby fees place the District and its other customers in a financially unsustainable position by reducing ongoing revenue and future impact fee revenue.
2. Effective January 1, 2018, the District will no longer extend the impact fee waiver to customers who fall behind on their standby fee payment beyond 90 days. Customers over 90 days delinquent as of Jan 1, 2018 will have until March 31st, 2018 to come current on past due standby fees. Previous standby customers may receive a credit toward the impact fee in an amount equal to the total standby fees paid.

### **1.04.030 Disputed Bills**

#### A. Disputed Customer Billing:

1. If a customer believes that a bill is incorrect, the billing may be protested in writing only by mail or email. A copy of the envelope providing proof of the postmark must be submitted. Staff will fill out a customer billing protest form.
2. All protests shall be made within fifteen (15) days of the postmark date, or the protest is waived. The time period for allowing protests shall be set forth on the Water Application Agreement and/or monthly statement.
3. Disputed bills shall not be declared delinquent during the time the dispute is unresolved. Upon resolution of the dispute, a new statement showing the revised charges to the customer shall be issued. The payment of said revised charges shall become delinquent fifteen (15) days after the statement date of the new bill. If said charges are not paid, the water service may be terminated as provided in sections 1.04.020.D et seq.

4. Late fees shall not be charged from the time the customer notifies the District of the dispute and the five (5) days after the time the staff makes a determination about classification.
5. In the event that a dispute remains unresolved in excess of thirty (30) days after protest, legal action may be initiated by the District to resolve the dispute and to collect the lawful amounts due the District.

B. Procedures for Investigating Customer Billing:

1. District Staff will schedule a time with the Water Superintendent to manually read the meter.
2. After the meter has been manually read, the Water Superintendent will then make a determination about how to classify the water usage billed as:
  - a. Water used by the customer,
  - b. A water leak, or
  - c. A meter reading error.
3. Billing classified by the Water Superintendent as water used by the customer will result in the District Staff reversing actions in A(3) and ensuring the customer's account accurately reflects the usage, unless the customer elects to appeal the Water Superintendent's decision to the District Board as outlined in section B(6).
4. Billing classified as a water leak can be recalculated to reflect the usage of the same month in the last year.
5. Billing classified as a meter reading error shall be corrected to accurately reflect water usage.
6. Appeal of Water Superintendent's Classification: Customers are permitted to appeal classifications of water usage billed made by the Water Superintendent (as outlined in section B(1)) to the District Board as follows:
  - a. The customer must fill out an Application to Appear Before the Board of Directors.
  - b. The District Staff will place the application on the agenda of the next available District regular meeting.

**1.05.000 Rates, Charges, And Fees**

- A. All rates, charges, and fees presently existing and hereafter established, shall be set and changed from time to time by the Board of Trustees. Rates, charges, and fees shall be reasonably related, to the extent possible, to the cost of providing the service for which they are assessed. A schedule of current fees and charges in effect is set forth in Appendix A.

**1.06.000 Service Connections**

- A. To the extent practicable, each residential service connection shall supply only one single family dwelling unit.
- B. Upon installation, the service connection becomes the property of and responsibility of the District from the water main through the meter to the point of connection with the pipe stubbed from the building, said point of connection being immediately downstream of the meter box. The

meter, as part of the service connection, shall be repaired or replaced by the District, unless it becomes damaged or inoperable due to intentional damage by the customer. The District shall have the right to estimate the amount of water used during the time the meter is inoperable. Such estimate shall be based upon past usage by the customer, usage by a customer with similar circumstances, or any other relevant criteria.

- C. Repair of leaks and service of plumbing on the customer side of the service connection shall be the responsibility of the customer. As such, water lost through a leak or open valve on the customer side of the service connection shall be paid for by the customer at the prevailing rates for water. The District will attempt to notify the customer if a leak is suspected. If the meter has not been read for more than two months, the District will adjust the customer's bill by charging its average wholesale water rate for the estimated amount of water lost because of the leak. The bill will not be adjusted until the customer has presented sufficient proof of repairing the break.
- D. Where possible, the meter and service connection shall occupy the public right-of-way. In cases where this is not possible, the meter may be situated on the customer's property. The District shall have the right of access to water meters wherever located for inspection, meter reading, as well as for connection service and maintenance. The customer shall not do, allow, or cause to be done, any act or condition which would in any way impair or prevent the District's access to its meter or service connection.
- E. The District shall periodically, or upon reasonable request of the customer, test water meters for accuracy. Faulty meters shall be repaired or replaced by the District.
- F. Any customer who tampers with, damages, or destroys a meter in any manner, shall be liable to the District for all costs associated with returning the meter to its normal operation.
- G. The District retains the right to inspect any conditions within or associated with a facility that may put the District's system and/or water supply at risk for contamination. If a condition is discovered that may seem a risk, written notification shall be given to the customer along with a request for the customer's response and a proposed correction determined by the District based upon the severity of the hazard. If, thereafter, the hazard is not corrected to the District's satisfaction, or the District determines the risk to public health to be imminent, water service shall be terminated immediately. Service shall not be resumed until the hazard is removed or adequately protected as determined by the District.
- H. Whenever the District, acting through its inspectors, determines that a water service connection is a hazard to the District's system and/or water supply, a backflow prevention device and/or assembly shall be installed in accordance with the current plumbing code as adopted by the State of Utah and/or as contained in the Cross Connection Control Program for Utah maintained by the Utah Department of Environmental Quality, Division of Drinking Water. All backflow prevention assemblies shall be installed by the customer on the service line of the customer's water system, at or near the property line, or immediately inside the building being served; but in all cases, before the first branch line leading off the service line. Within ten (10) working days following the initial installation, the customer shall obtain a certified inspection and operational testing of the backflow prevention assembly and furnish the results to the District. Thereafter, the customer shall obtain a certified inspection and operational testing of each backflow prevention assembly conducted at least once per year and furnish those results to the District. In instances where the District deems the hazard to be great, the customer shall obtain certified inspections more frequently as required by the District. The inspections and tests shall comply with standards established by the current plumbing code adopted by the State of Utah and/or the Cross-Connection Control Program for Utah maintained by the Utah Department of Environmental Quality, Division of Drinking Water.
- I. All presently installed backflow prevention assemblies which do not meet the requirements of this Chapter as of October 22, 2005, but which were approved for the purposes described herein at the time of installation before that date, and which have been properly maintained, shall satisfy

the requirements of these rules so long as the District is assured that the assembly shall satisfactorily protect the public water system. The assemblies shall be subject to the current inspection, testing and maintenance requirements as outlined by the Cross-Connection Control Program for Utah maintained by the Utah Department of Environmental Quality, Division of Drinking Water. If the existing assembly is moved from the present location, requires more than minimum maintenance as determined by the District, fails to operate properly during a testing exercise, or is determined to be hazardous by the District, the unit shall be replaced by the customer with a backflow prevention assembly which meets all then current requirements at the time of installation.

- J. No backflow prevention assembly shall be installed so as to create a safety hazard (i.e., over an electrical panel, steam pipes, boilers, or above ceiling level). All backflow prevention assemblies must be installed according to the standards established by the current plumbing code adopted by the State of Utah and/or the Cross-Connection Control Program for Utah maintained by the Utah Department of Environmental Quality, Division of Drinking Water, and must be easily accessible for testing by the District.
- K. Forfeiture of Connections: Upon request, the District Board may approve the forfeiture of standby or metered connections for extenuating circumstances to be determined by the District Board. If the District Board agrees to allow the forfeiture of a connection, it is District policy that the owner of the connection to be forfeited is not entitled to any compensation or credit for any fees or financial obligations paid with respect to that connections, including connection fees, impact fees, standby and usage fees, as well as physical water requirements previously transferred to the District.

#### **1.07.000 Multiple Units**

- A. The owner of the property shall be liable for payment of all water delivered to the various units.
- B. If two or more buildings are connected to the same meter, and if their ownership should become severed, the original owner shall remain liable for payment of all water usage until separate meters can be placed in service for each building. The new owner shall be liable for all costs associated with the new service connection.

#### **1.08.000 Fire Hydrants And Fire Lines**

- A. The cost of installation and materials for fire hydrants, fire lines, and Detector Check Systems, shall be borne by those benefitting from the location of the facilities, as determined by the District. Upon installation, the hydrants, fire lines, and Detector Check Systems shall become the property of the District.
- B. Existing hydrants will be inspected, maintained, and replaced as determined by the District.
- C. Use of fire hydrants without permission of the District, except by the Fire Department, is prohibited.
- D. The District shall have the right to approve the type of fire hydrant together with the design, specifications, and installation of all fire lines and Detector Check Systems. A Detector Check System is required when installing a fire line.
- E. Each month the Detector Check Systems shall be inspected to ensure the valves are turned on and to check for water use. Any unauthorized use shall be billed to the customer.
- F. The cost of inspecting and maintaining fire lines and Detector Check Systems shall be billed to the customer according to an approved fee schedule.

#### **1.09.000 Water Main Extensions**

- A. The District requires main line extensions for all new structures requiring a building permit from the Town of Apple Valley. This requirement applies to all new building permit structures whether the permittee has independent water service from other Sources or not. The District has the mandate from the Town's Fire Department to provide fire protection service throughout the community. Main line extensions that are a part of a subdivision or a commercial development will be incorporated into the Development plans to be submitted to the District. Development plans submitted to the District will be reviewed based on the District's Design Standards. Main line extensions that are not part of a development project require main line engineered drawings. The main line extension applicant may submit plans for review and/or coordination with the District's Engineer, but must obtain necessary approvals from the District before any main line extensions can be constructed. The final approval shall include the Engineer and the Water Superintendent with final authorization issued by the Water Superintendent.
- B. The cost of service for review and inspections for main line extensions will be charged the cost of service based on time and materials at the District's published rates, including multiple review cycles.
- C. Any residential or commercial developer must request retail water service by signing a Water Application Agreement with the District before installation of water mains, fire hydrants, or other waterworks required by the District.
- D. To the extent practicable, the cost of installing water line extensions shall be borne by those benefitting from the extensions, as determined by the District.
  - 1. If, in the discretion of the District, projected future water needs require a water main of greater size than that needed for the development alone, the District may require that a larger water main be installed.
- E. Existing water mains shall be maintained and replaced by the District.
- F. All water main extensions shall become the property of the District, subject to the terms of the Extension Agreement.

#### **1.10.000 Upgrading Size Of Connections**

- A. Customers desiring a larger service connection than is presently in place shall be charged the actual cost of up-sizing the connection.

#### **1.11.000 All Other Services**

- A. All other services to be rendered by the District shall be negotiated between the customer and District, and shall be approved by the District Board. Every effort shall be made to ensure that fees charged for services rendered reasonably correspond with costs incurred by the District for such services.

#### **1.12.000 General Provisions And Obligations**

- A. Limitation of Liability: The District shall not be responsible for disruptions, irregularities or failure of service caused by broken water mains, power outages, equipment failure, or other circumstances beyond its reasonable control, and in no event shall the District be liable for any damage of any kind resulting therefrom.
- B. In the case of an emergency such as a natural disaster, the District solicits the cooperation of all customers. During such emergencies, the District will make every effort to keep its customers informed of the status and adequacy of its water supply.

- C. The District reserves the right at any time, without notice, to shut off or curtail water deliveries through its mains for the purpose of making repairs or extensions or for other purposes, and no claim shall be made against the District, by reason of any breakage whatsoever, or for any damage that may result from shutting off the water for repairing, laying, or relaying mains, hydrants, or other connections, or for any other reason whatsoever, including natural causes. The District will attempt to provide notice to customers affected by a shut-off when adequate time exists to give such notice.
- D. In the event of scarcity of water, the District Board may, by proclamation, limit the use of water for any purpose to the extent as in its judgment is required for the public good. In the event of such scarcity, and in the event that a meeting of the District Board cannot be convened before preventative action is required, the District's Chairman may issue a proclamation limiting the use of water. Said proclamation shall have full force and effect until such time as the District Board shall be able to meet.
- E. The provisions of these rules and regulations shall be severable. If any provisions hereof, or the application of such provision under any circumstances is held invalid, it shall not affect any other provision of these rules and regulations, or its application in a different circumstance.
- F. No customer shall create or allow to exist any condition or activity which causes a District employee reasonable fear and/or apprehension for the safety of the employee's person and/or personal property in the possession or custody of the employee.
- G. Any District employee who reasonably fears for his personal safety or for the safety of personal property in the possession or custody of the employee, may take all reasonable acts, or refrain from acting, as the employee deems necessary to provide appropriate protection.
- H. An individual who tampers with District facilities for the purpose of stealing water will be subject to fines and charged for water and services used.
- I. Tampering with the water in any way will result in a \$750 fine for the first offense, and \$1,500 for subsequent offenses, and will result in criminal prosecution. Tampering is considered the unauthorized manipulation or change of any water apparatus or related equipment in any fashion. All water related equipment including the meter and the meter can is considered the property of the Big Palins Water Special Service District.
- J. In the event a customer violates any of the District's policies, rules and/or regulations, the District may take such remedial action as it deems appropriate, including but not limited to the termination of water service to the customer.

### **1.13.000 Control Of Backflow And Cross Connections**

#### **1.13.010 Definitions**

#### **1.13.020 General Policy**

#### **1.13.030 Responsibility: Water Superintendent/Inspector**

#### **1.13.040 Responsibility: Consumer**

#### **1.13.050 Responsibility: Certified Backflow Technician, Surveyor, Or Repair Person**

#### **1.13.060 Responsibility: Repair Of Backflow Assemblies**

#### **1.13.070 Requirements**

#### **1.13.080 Violations Of This Policy**

### **1.13.010 Definitions**

- A. **APPROVED BACKFLOW ASSEMBLY:** An assembly accepted by the Utah State Department of Environmental Quality, Division of Drinking Water, as meeting an applicable specification or as suitable for the proposed use.

- B. **AUXILIARY WATER SUPPLY:** Any water supply on or available to the premises other than the Water Superintendent public water supply will be considered as an auxiliary water supply. These auxiliary waters may include water from another Water Superintendent's public potable water supply or any natural source(s) such as a well, spring, river, stream, etc., or "used waters" or "industrial fluids". These waters may be contaminated or polluted or they may be objectionable and constitute an unacceptable water source over which the Water Superintendent does not have authority for sanitary control.
- C. **BACKFLOW:** The reversal of the normal flow of water caused by either back-pressure or back-siphonage.
- D. **BACK-PRESSURE:** The flow of water or other liquids, mixtures, or substances from a region of high pressure to a region of lower pressure into the water distribution pipes of a potable water supply system for any source(s) other than the intended source.
- E. **BACK-SIPHONAGE:** The flow of water or other liquids, mixtures, or substances under vacuum conditions into the distribution pipes of a potable water supply system from any source(s) other than the intended source, caused by the reduction of pressure in the potable water system.
- F. **BACKFLOW PREVENTION ASSEMBLY:** An assembly or means designed to prevent backflow. Specifications for backflow prevention assemblies are contained within the Water Design Standards 01.16.000, as adopted by the State of Utah and in the Cross-Connection Control Program for Utah maintained by the Division of Drinking Water.
- G. **CONTAMINATION:** Means a degradation of the quality of the potable water supply by sewage, industrial fluids or waste liquids, compounds or other materials that may create a health hazard.
- H. **CROSS CONNECTION:** Any physical connection or arrangement of piping or fixtures which may allow non-potable water or industrial fluids or other material of questionable quality to come into contact with potable water inside a water distribution system. This would include temporary conditions, such as swing connections, removable sections, four-way plug valves, spools, dummy sections of pipe, swivel or change-over devices or sliding multiport tubes or other plumbing arrangements.
- I. **CROSS CONNECTION-CONTROLLED:** A connection between a potable water system and a non-potable water system with an approved backflow prevention assembly properly installed and maintained so that it will continuously afford the protection commensurate with the degree of hazard.
- J. **CROSS CONNECTION-CONTAINMENT:** The installation of an approved backflow assembly at the water service connection to any customer's premises where it is physically and economically infeasible to permanently eliminate or control all actual or potential cross connections within the customer's water distribution system; or, it shall mean the installation of an approved backflow prevention assembly of the service line leading to and supplying a portion of a customer's water system where there are actual or potential cross connections which cannot be effectively eliminated or controlled at the point of the cross connection (isolation).
- K. **WATER SUPERINTENDENT:** The person designated to be in charge of the District water operations, is invested with the authority and responsibility for the implementation of an effective cross connection control program and for the enforcement of the provisions of this policy.

### **1.13.020 General Policy**

#### A. Purpose of Policy

1. To protect the Public drinking water supply of the District from the possibility of contamination or pollution by requiring compliance with the Utah Public Drinking Water Rules (UPDWR) and the Plumbing Code as adopted by the State of Utah, and requiring a

cross connection control protection of all public drinking water systems in the State of Utah. Compliance with these minimum safety codes will be considered reasonable diligence for the prevention of contaminants or pollutants which could backflow into the public drinking water system; and,

2. To promote the reasonable elimination or control of cross connections in the plumbing fixtures and industrial piping system(s) of the consumer, as required by the state regulations and plumbing code to assure water system safety; and to provide for administration of a continuing program of backflow prevention which will systematically examine risk and effectively prevent contamination or pollution of the drinking water system.

### **1.13.030 Responsibility: Water Superintendent/Inspector**

#### A. Responsibility: Water Superintendent

1. The Water Superintendent shall be responsible for the protection of the drinking water distribution system from the foreseeable conditions leading to the possible contamination or pollution of the drinking water system due to the backflow of contaminants or pollutants into the drinking water supply.
2. Drinking water system surveys/inspections of the consumer's water distribution system(s) shall be conducted or caused to be conducted by individual's deemed qualified by and representing the District, i.e., Water Superintendent. Survey records shall indicate compliance with the State of Utah regulations. All such records will be maintained by the District.
3. The District shall schedule and notify in writing, all consumers of the need for the periodic system survey to ensure compliance with existing applicable minimum health and safety standards.
4. Selection of an approved backflow prevention assembly for containment control required at the service entrance shall be determined from the results of the system survey.
5. The Water Superintendent's responsibility to enforce the applicable sections of the plumbing code begins at the point of service (downstream or consumer side of the meter) and continues throughout the length of the consumer's water system.
6. The Water Superintendent will review all plans to ensure that unprotected cross connections are not an integral part of the consumer's water system. If a cross connection cannot be eliminated, it must be protected by the installation of an air gap or an approved backflow prevention device/assembly, in accordance with the adopted Plumbing Code.

### **1.13.040 Responsibility: Consumer**

#### A. Responsibility: Consumer

1. To comply with this policy as a term and condition of water supply and consumer's acceptance of service is admittance of his/her awareness of his/her responsibilities as a water system user.
2. It shall be the responsibility of the consumer to purchase, install, and arrange testing and maintenance of any backflow prevention device/assembly required to comply with this policy. Failure to comply with this policy shall constitute grounds for discontinuation of water service.

### **1.13.050 Responsibility: Certified Backflow Technician, Surveyor, Or Repair Person**

#### A. Responsibility: Certified Backflow Technician, Surveyor, or Repair Person

1. Whether employed by the consumer or a utility to survey, test, repair, or maintain backflow prevention assemblies, the Certified Backflow Technician, Surveyor, or Repair Person will have the following responsibilities:
  - a. Ensuring that acceptable testing equipment and procedures are used for testing, repairing or overhauling backflow prevention assemblies.
  - b. Make reports of such testing and/or repairs to the consumer and the Water Superintendent on form approved for such use by the Water Superintendent within time frames as described by the Division of Drinking Water.
  - c. Include the list of materials or replacement parts being used on the reports.
  - d. Insuring that replacement parts are equal in quality to parts originally supplied by the manufacturer of the assembly being repaired.
  - e. Not changing design, material or operational characteristics of the assembly during testing, repair or maintenance.
  - f. Performing all test of the mechanical devices/assemblies and shall be responsible for the competence and accuracy of all test reports.
  - g. Insuring that his/her license is current, the testing equipment being used is acceptable to the State of Utah, and is in proper operating condition.
  - h. Being equipped with, and competent to use, all necessary tools, gauges, and other equipment necessary to properly test, and maintain backflow prevention assemblies.
  - i. Tagging each double check valve, pressure vacuum breaker, reduced pressure backflow assembly and high hazard air gap, showing the serial number, date tested and by whom. The certified technician's license number must also be on the tag.

### **1.13.060 Responsibility: Repair Of Backflow Assemblies**

#### A. Responsibility: Repair of Backflow Assemblies

1. In the case of consumer requiring an assembly to be tested, any currently Certified Backflow Technician is authorized to make the test and report the results to the consumer and the Water Superintendent. The installation, replacement or repair of assemblies must be made by a tester having appropriate licensure from the Department of Commerce, Division of Occupational and Professional Licensing, except when the Backflow Technician is an agent of the assembly owner.

### **1.13.070 Requirements**

- A. No water service connection to any premises shall be installed or maintained by the Water Superintendent unless the water supply is protected as required by State laws, regulations, codes, and this policy. Service of water to a consumer found to be in violation of this policy shall be discontinued by the Water Superintendent after due process of written notification of violation

and an appropriate time for voluntary compliance and will not be restored until such conditions or defects are corrected, if:

1. A backflow prevention assembly required by this policy for the control of backflow and cross connections is not installed, tested, and maintained; or
  2. If it is found that a backflow prevention assembly has been removed or by-passed; or
  3. If an unprotected cross connection exists on the premises; or
  4. If the periodic system survey has not been conducted.
- B. The customer's system(s) shall be open for inspection at all reasonable times to authorized representatives of the District to determine whether cross connections or other structural or sanitary hazards, including violation of this policy exist and to audit the results of the required survey (R309-400 of the Utah Administrative Code).
- C. Whenever the District deems a service connection's water usage contributes a sufficient hazard to the water supply, an approved backflow prevention assembly shall be installed on the service line of the identified consumer's water system, at or near the property line or immediately inside the building being served; but , in all cases, before the first branch line leading off the service line.
- D. The type of protective assembly required under C, shall depend upon the degree of hazard which exist at the point of cross connection (whether direct or indirect), applicable to local and state requirements or resulting from the required survey.
- E. All presently installed backflow prevention assemblies which do not meet the requirements of this section but were approved assemblies for the purposes described herein at the time of installation and which have been properly maintained, shall, except, for the inspection and maintenance requirement under F, be excluded from the requirements of these rules so long as the District is assured that they will satisfactorily protect the public water system. Whenever an existing backflow prevention assembly is moved from the present location or, requires more than minimum maintenance or, when the District finds that the operation or maintenance of this assembly constitutes a hazard to health, the unit shall be replaced by an approved backflow prevention assembly meeting all local and state requirements.
- F. It shall be the responsibility of the consumer at any premises where backflow prevention assemblies are installed to have certified surveys/inspections, and operational tests made at least once per year at the consumer's expense. In those instances where the District deems the hazard to be great, it may require certified surveys/inspections and tests at a more frequent interval. It shall be the duty of the District to see that these tests are made according to the standards set forth by the State Department of Environmental Quality, Division of Drinking Water.
- G. All backflow prevention assemblies shall be tested within ten (10) working days of initial installation.
- H. No backflow prevention assemblies shall be installed so as to create a safety hazard. Example: Installed over an electrical panel, steam pipes, boilers, or above ceiling level.

### **1.13.080 Violations Of This Policy**

- A. If violations of this policy exist or if there has not been any corrective action taken by the consumer within ten (10) days of the written notification of the deficiencies noted within the survey or test results, then the District shall deny or immediately discontinue water service to the premises by providing a physical break in the service line until the customer has corrected the condition(s) in conformance with all State and local regulations and statutes relating to plumbing, safe drinking water suppliers, and this policy.

## **1.14.000 Well Drilling Policy**

A. Multiple users and well sharing agreements are not allowed on private wells. Wells are for single use only and must be located on the User's property.

### **B. Permit Required; Prohibition Against Drilling or Use of a Water Supply Well**

1. No person, firm, or corporation or other entity shall drill a well or cause a well to be drilled without applying for and receiving a permit from the District. no permit shall be issued until the requisite fee has been paid by the applicant. A person whose property is served by public water supply or is within 1,000 feet of the District service lines, may not drill or use for any purpose a water supply well where the groundwater which may be pumped by such well.

### **C. Contents of Permit**

1. A permit application shall be made in writing to the District and shall contain the following information:
  - a. The applicant's name, address and telephone number.
  - b. The name, address and telephone number of the person, firm, corporation or other entity who will drill the well.
  - c. The name of the property owner upon whose property the well will be drilled and, if applicable, authorization to perform the drilling.
  - d. An accurate description of the location of where the well will be drilled.
  - e. Clear and convincing evidence that the application will not further deplete the District's water supply.
  - f. Copies of all documents submitted to the State of Utah showing compliance with existing Utah law.
  - g. Approval from the State of Utah to drill the well.

### **D. Emergency When There Is an Existing Well.**

1. Notwithstanding any of the above provisions, a property owner with an existing well may drill a well or drill an existing well deeper and make application for a permit within three business days after drilling a well under the following conditions:
  - a. The well fails; and
  - b. It is not possible to obtain a permit prior to the well driller's availability to drill and/or redrill or deepen the existing well.

### **E. Reporting the Drilling of a Well after Completion.**

1. Upon the completion of the well, the person, firm or entity drilling the well shall immediately submit to the District all of the information and reports which the person, firm or entity must submit to the State of Utah or any agencies thereof pursuant to the State's laws, rules and regulations.

### **F. Fees.**

1. The fee for a permit shall be \$250 and shall accompany the application for a permit.

## G. Violations and Penalties.

1. Any person, firm, corporation, or other entity who shall violate any provisions of this Part, upon conviction thereof in any action brought before a District Court in a manner provided for the enforcement of summary offenses under the Utah Rules of Criminal Procedure, shall be sentenced to pay a fine of not less than \$1,000, plus costs. Each day the violation continues without a permit shall constitute a separate offense.

## H. Severability Clause.

1. If any part or provision of this Policy is held invalid or unenforceable, such invalidity or unenforceability shall not affect any other portion of this Policy and all provisions, clauses and words of this Policy shall be severable.

## **01.15.000 Bulk Water Sales**

- A. Bulk Water Sales: Customers may apply for rental of a bulk meter for bulk water purchase.
- B. Application Required. Customers will apply for bulk water purchase by filling out an application for bulk water meter rental.
- C. Procedures for Processing Bulk Water Applications: The District Staff will review the application for completeness and ensure all fees are paid. The District Staff will then annotate the meter number and the current meter reading. The District Staff will then schedule a time for the applicant to pick up the meter from the Town office.
- D. Verbal Communication with Water Superintendent Required: Bulk Water Customers are required to verbally communicate with the Water Superintendent before usage. The Water Superintendent will inform the customer which hydrant to use and instruct the applicant on safe use.
- E. Deposit and Other Fees. A \$1,000 deposit fee must be submitted to be on file during the rental of the bulk water meter. Fees for the rental and water usage can be found in Appendix A.
- F. The Customer must report the location the water is being used on. If the meter needs to be moved, the location must be reported to the District Staff.
- G. Loaning or subletting the meter, or removing water from the Town of Apple Valley is strictly prohibited.
- H. Customers Must Use Designated Hydrant. The Water Superintendent will inform the customer of which hydrant to use. The Customer must use the designated hydrant or hydrants, or the bulk use agreement will be terminated.
- I. Customers Responsible for Meter Reading. Customers are required to bring the bulk use meter into the Town office by the last day of the usage month according to the date of application. Failure to bring the meter in by the 5th day of the following usage month will result in a \$240 fee. Failure to bring it in within 30 days following a usage month will result in an additional \$250 fee and the termination of the bulk water usage agreement.
- J. Customers Responsible for Damage or Loss. Any damage to or loss of meter, fire hydrant, other equipment or property will be paid for at the expense of the customer.
- K. Tampering with Meter Prohibited. Any intentional tampering with the meter, to include customers attempting to repair the meter, will result in termination of the bulk meter usage agreement.
- L. All provisions stated on the application are applicable and shall be adhered to. A lien may be placed on the property being serviced for all unpaid charges and cost of collection. Anyone who

maliciously, willfully, or negligently consumes water from the District without District approval may be subject to misdemeanor charges.

### **01.16.000 Water Design Standards**

[Water Valve Box Detail; Blow Off Detail](#)

[Standard Fire Hydrant Detail \(Paved And Unpaved\)](#)

[Thrust Blocks](#)

[6" Pressure Reducing Valve W/2" Bypass-Profile View](#)

[6" Pressure Reducing Valve W/2" Bypass-Plan View](#)

[1"-2" Water Meter-Plan View](#)

[1"-2" Water Meter-Profile View](#)

[Waterline Utility Crossing Detail](#)

[Water Meter With Fire Flow-Plan View](#)

[Water Meter With Fire Flow-Profile View](#)

[Trench Detail](#)

[Air Release Valve Detail](#)

[Carrier Pipe Detail-Cross Section](#)

[Backflow Detail](#)

[Pipe Fixtures-Plan View](#)

[Assorted Details](#)

[Meter Pedestal For Riser Connection](#)

[RTU Pedestal Elevations-Front And Back](#)

[RTU Pedestal Side Elevation](#)

[Vent Pipe Side Penetration](#)

[Pipe Fixtures-Plan And Profile View](#)

[Pipe Fixtures-Profile View](#)

[Pressure Gauge W/Hose Bib](#)

[Typical Cable Tool Well Section](#)

[Typical Screened/Gravel Packed Well Section](#)

[Hot Tap Plan View And Section View](#)

**Water Valve Box Detail; Blow Off Detail**

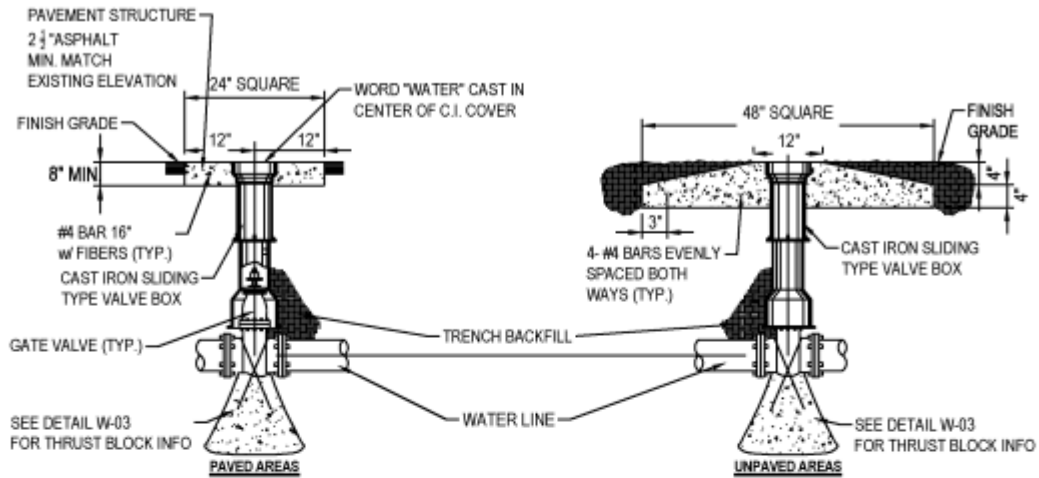

1 WATER VALVE BOX DETAIL SCALE: NONE

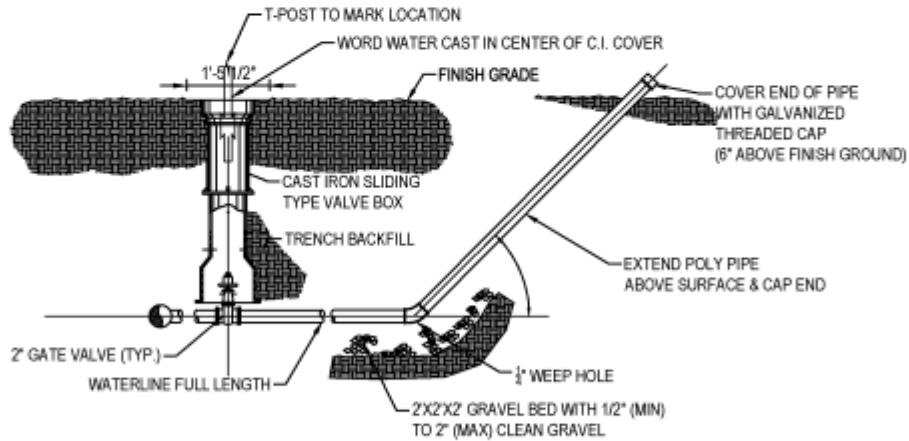

2 BLOW OFF DETAIL SCALE: NONE

PROJECT # SU1011	DATE 09/22/2017	<b>BIG PLAINS WATER SSD</b> <b>STANDARD DETAILS</b> <b>WATER VALVE BOX AND BLOW OFF</b> <b>WASHINGTON COUNTY, UTAH</b>		<b>BIG PLAINS WATER SSD</b> 1777 N. Meadowlark Drive Apple Valley, Utah 84737 Phone 435-877-1190 Fax 435-877-1192
<b>W-01</b>				

**Standard Fire Hydrant Detail (Paved And Unpaved)**

NOTE:

1. TOP OF VALVE BOX AND CONCRETE COLLAR TO BE 1/4" BELOW FINAL GRADE.

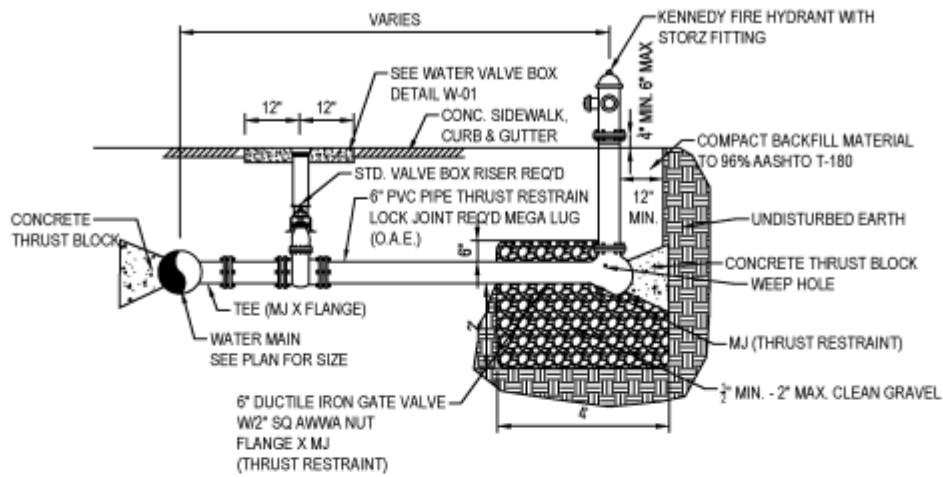

1 STANDARD FIRE HYDRANT DETAIL (PAVED) SCALE: NONE

NOTE:

1. TOP OF VALVE BOX AND CONCRETE COLLAR TO BE 1/4" BELOW FINAL GRADE.

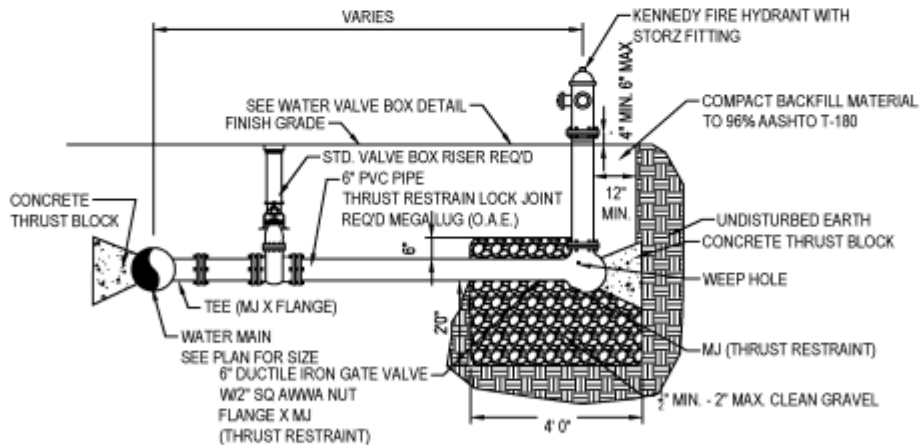

2 STANDARD FIRE HYDRANT DETAIL (UNPAVED) SCALE: NONE

PROJECT # SU1011 DATE 09/22/2017 <b>W-02</b>	<b>BIG PLAINS WATER SSD</b> <b>STANDARD DETAILS</b> STANDARD FIRE HYDRANT DETAIL WASHINGTON COUNTY, UTAH		BIG PLAINS WATER SSD 1777 N. Meadowlark Drive Apple Valley, Utah 84737 Phone 435-877-1190 Fax 435-877-1192
--	---	--	--

Thrust Blocks

NOTE:

1. CONCRETE SHALL NOT BE PLACED AROUND JOINTS AND BOLTS.
2. BLOCKING SHALL BE POURED IN PLACE PORTLAND CEMENT CONCRETE A MINIMUM OF 12 INCHES THICK BETWEEN SOLID UNDISTURBED OR COMPACTED EARTH AND FITTING. THRUST BLOCK SHALL BE PLACED TO PERMIT ACCESS TO THE PIPE AND FITTING.
3. MINIMUM BEARING AREAS ASSUME A WORKING PRESSURE OF UP TO 150 PSI (TEST PRESSURE 200 PSI) AND A MINIMUM SOIL BEARING PRESSURE OF 2000 PSI. IF THESE CONDITIONS ARE NOT MET, LARGER BLOCKING WILL BE REQUIRED.

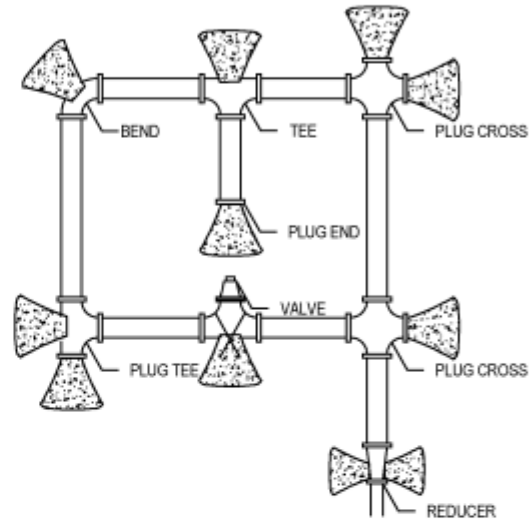

1 THRUST BLOCKS SCALE NONE

PROJECT # SU1011	DATE 09/22/2017	<b>BIG PLAINS WATER SSD</b> <b>STANDARD DETAILS</b> THRUST BLOCKS WASHINGTON COUNTY, UTAH		BIG PLAINS WATER SSD 1777 N. Meadowlark Drive Apple Valley, Utah 84737 Phone 435-877-1190 Fax 435-877-1192
---------------------	--------------------	--	--	--

**6" Pressure Reducing Valve W/2" Bypass-Profile View**

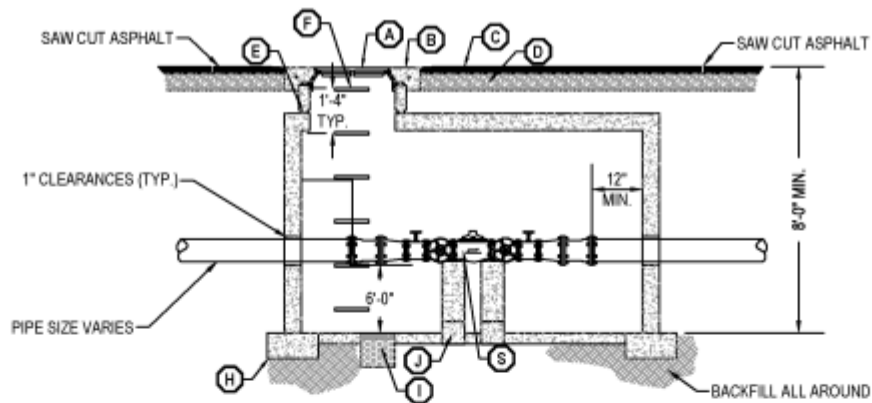

1 6" PRESSURE REDUCING VALVE W/2" BYPASS-PROFILE VIEW SCALE: NONE

NOTE:  
1. UNLESS OTHERWISE SHOWN ALL MATERIALS PER BWPSSSD ENGINEERING STANDARDS

LEGEND			
NO.	*	ITEM	DESCRIPTION
A		MANHOLE RING AND COVER (RIBLESS)	D&L A-1180 O.A.E.
B		4' X 8" THICK CONCRETE COLLAR	W 40' / #4 BARS & FIBERS
C		3" ASPHALT MAT	
D		8" COMPACTED UNTREATED BASE	
E		GRADE RING(S)	
F		MANHOLE STEP	(M.A. INDUSTRIES INC. O.A.E.)
G		CONCRETE VAULT TOP (6'X 12')	AMCOR UV6127T O.A.E.
H		9" X 18" FOOTING W/ 3-#4 BARS	
I		SUMP	12" X 12" X 12" WISUMP PUMP & GRATE
J		CONCRETE SUPPORT BLOCKING	
K		x" M.J. X FLANGE ADAPTOR	CEMENT LINED
L		x" X 6" FLANGED REDUCER (IF REQ'D)	CEMENT LINED
M		6" FLANGED STEEL SPOOL WITH 2" OUTLET	EPOXY COATED AND LINED
N		2" GATE VALVE WITH HANDWHEEL	
O		6" GATE VALVE WITH HANDWHEEL	NON-RISING STEM
P		6" PRESSURE REDUCING VALVE	WATTS ACV 115/6115 O.A.E.
Q		2" K-COPPER PIPE AND FITTINGS AS SHOWN	
R		2" PRESSURE REDUCING VALVE	
S		3/4" TAPPS w/ PRESSURE GAUGE	2 1/2", 0-300 PSI, GLYCERIN FILLED

PROJECT # SU1011 DATE 09/22/2017 <b>W-04A</b>	<b>BIG PLAINS WATERSSD</b> <b>STANDARD DETAILS</b> <b>6" PRESSURE REDUCING VALVE W/2" BYPASS- PROFILE</b> <b>WASHINGTON COUNTY, UTAH</b>		BIG PLAINS WATER SSD 1777 N. Meadowlark Drive Apple Valley, Utah 84737 Phone 435-877-1190 Fax 435-877-1192
---	---	--	--

**6" Pressure Reducing Valve W/2" Bypass-Plan View**

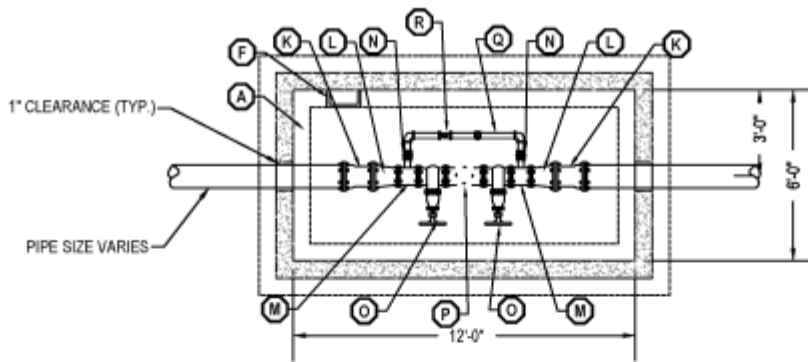

4 6" PRESSURE REDUCING VALVE W/2" BYPASS-PLAN VIEW  
SCALE: NONE

NOTE:  
1. UNLESS OTHERWISE SHOWN ALL MATERIALS PER BWPSSD ENGINEERING STANDARDS

LEGEND			
NO.	*	ITEM	DESCRIPTION
A		MANHOLE RING AND COVER (RIBLESS)	D&L A-1180 O.A.E.
B		4' X 8' THICK CONCRETE COLLAR	W/ 40' / #4 BARS & FIBERS
C		3" ASPHALT MAT	
D		8" COMPACTED UNTREATED BASE	
E		GRADE RING(S)	
F		MANHOLE STEP	(M.A. INDUSTRIES INC. O.A.E.)
G		CONCRETE VAULT TOP (6'X 12')	AMCOR UV6127T O.A.E.
H		9' X 18" FOOTING W/ 3-#4 BARS	
I		SUMP	12' X 12' X 12" W/SUMP PUMP & GRATE
J		CONCRETE SUPPORT BLOCKING	
K		x" M.J. X FLANGE ADAPTOR	CEMENT LINED
L		x" X 6" FLANGED REDUCER (IF REQ'D)	CEMENT LINED
M		6" FLANGED STEEL SPOOL WITH 2" OUTLET	EPOXY COATED AND LINED
N		2" GATE VALVE WITH HANDWHEEL	
O		6" GATE VALVE WITH HANDWHEEL	NON-RISING STEM
P		6" PRESSURE REDUCING VALVE	WATTS ACV 1156115 O.A.E.
Q		2" K-COPPER PIPE AND FITTINGS AS SHOWN	
R		2" PRESSURE REDUCING VALVE	
S		3/4" TAPPS W/ PRESSURE GAUGE	2 1/2", 0-300 PSI, GLYCERIN FILLED

PROJECT# DATE SU1011 09/22/2017 <b>W-04B</b>	<b>BIG PLAINS WATER SSD</b> <b>STANDARD DETAILS</b> 6" PRESSURE REDUCING VALVE W/2" BYPASS- PLAN WASHINGTON COUNTY, UTAH		BIG PLAINS WATER SSD 1777 N. Meadowlark Drive Apple Valley, Utah 84737 Phone 435-877-1190 Fax 435-877-1192
--	---	--	--

**1"-2" Water Meter-Plan View**

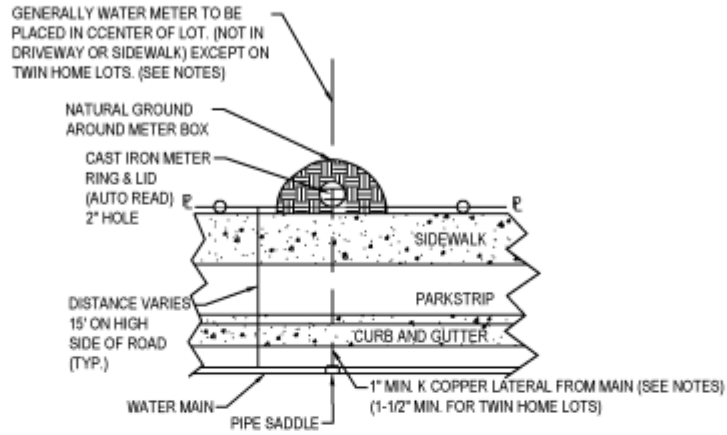

METER SIZE	BOX DIAMETER	D&L RING & COVER, OAE	FORD SETTER, OAE
1"	18"	L-2241	VBHC 74-18W-44-44-G or Q
1 1/2"	24"	B-5074	VBHH 76-18-44-66-G or Q
2"	30"	B-5076	VBHH 77-18-44-77-G or Q

1 1"-2" WATER METER-PLAN VIEW SCALE: NONE

PROJECT # SU1011 DATE 09/22/2017 <b style="font-size: 1.2em;">W-05A</b>	<b>BIG PLAINS WATER SSD</b> <b>STANDARD DETAILS</b> 1"-2" WATER METER-PLAN VIEW WASHINGTON COUNTY, UTAH		BIG PLAINS WATER SSD 1777 N. Meadowlark Drive Apple Valley, Utah 84737 Phone 435-877-1190 Fax 435-877-1192
--	--	--	--

**1"-2" Water Meter-Profile View**

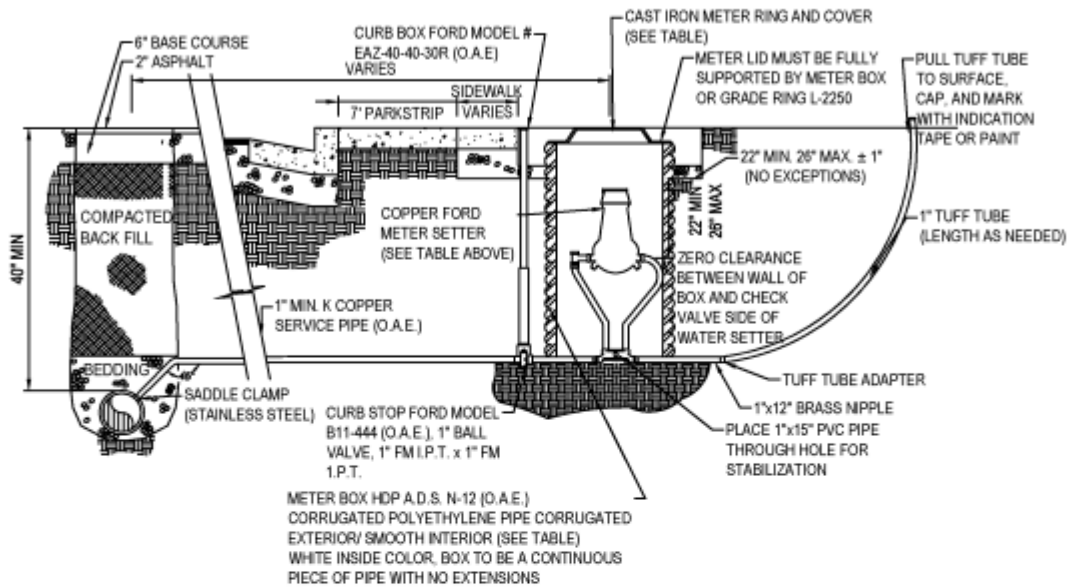

NOTES:

- 1- 3/4" LATERAL ALLOWED ONLY BY APPROVAL OF THE DISTRICT ENGINEER
- 2- ON TWIN HOME LOTS THE WATER METERS SHALL BE TEED OFF A COMMON 1-1/2" MIN. LATERAL COMING FROM THE MAIN AND PLACED ON EACH SIDE THE LOT DIVIDING LINE ACCORDING TO THE LAYOUT OF THE HOMES.

1 1'-2" WATER METER-PROFILE VIEW

SCALE: NONE

PROJECT # SU1011 <b>W-05B</b>	<b>BIG PLAINS WATER SSD</b> <b>STANDARD DETAILS</b> 1'-2" WATER METER-PROFILE VIEW WASHINGTON COUNTY, UTAH		BIG PLAINS WATER SSD 1777 N. Meadowlark Drive Apple Valley, Utah 84737 Phone 435-877-1190 Fax 435-877-1192
-------------------------------------	---	--	--

Waterline Utility Crossing Detail

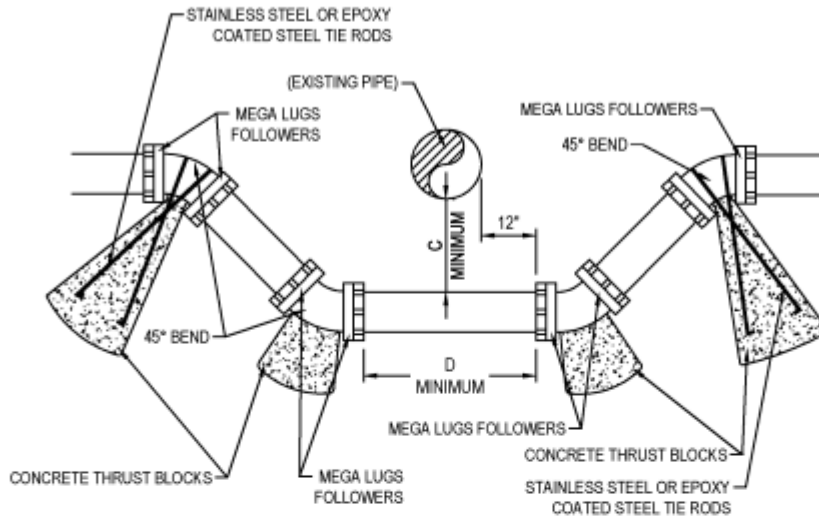

TABLE OF DIMENSIONS		
No.	OBSTRUCTION SEWER MAIN	OTHER
C	18"	12"
D MIN	FULL PIPE LENGTH	O.D. + 12"

NOTES:

1. MATCH EXISTING SERVICE. BEND PIPE AROUND OBSTRUCTION.
2. THRUST BLOCKS: NOT REQUIRED FOR FLANGE, WELDED, OR RESTRAINED JOINT PIPE SYSTEMS.
3. LOOP WATER MAINS OVER TOP OF SEWER LINES.
4. CONTRACTOR SHALL SUBMIT DETAILS OF RESTRAINED JOINT PIPE TO ENGINEER FOR APPROVAL PRIOR TO INSTALLATION.

1 WATERLINE UTILITY CROSSING DETAIL

SCALE: NONE

PROJECT # SU1011 DATE 09/22/2017 <b>W-06</b>	<b>BIG PLAINS WATER SSD</b> <b>STANDARD DETAILS</b> WATERLINE UTILITY CROSSING DETAIL WASHINGTON COUNTY, UTAH		BIG PLAINS WATER SSD 1777 N. Meadowlark Drive Apple Valley, Utah 84737 Phone 435-877-1190 Fax 435-877-1192
--	--	--	--

**Water Meter With Fire Flow-Plan View**

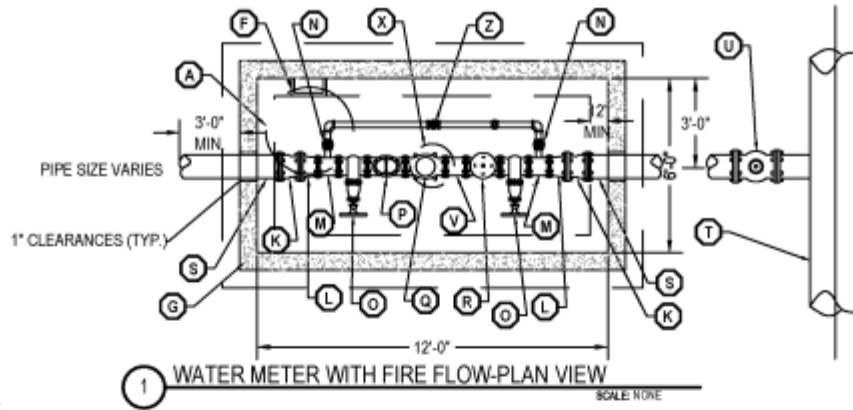

1 WATER METER WITH FIRE FLOW-PLAN VIEW SCALE NONE

NOTE:  
1. ALL MATERIALS PER CICWCD ENGINEERING STANDARDS UNLESS OTHERWISE SHOWN

NO.	ITEM	DESCRIPTION
A	MANHOLE RING AND COVER (RIBLESS)	D&L A-1180 O.A.E.
B	40 X 8" THICK CONCRETE COLLAR	W/ 40#M BARS & FIBERS
C	3" ASPHALT MAT	
D	8" COMPACTED UNTREATED BASE	
E	GRADE RING(S)	
F	MANHOLE STEP	(M.A. INDUSTRIES INC. O.A.E.)
G	CONCRETE VAULT TOP (6'X 12')	AMCOR UV6127T O.A.E.
H	9' X 18" FOOTING W/ 3-#4 BARS	
I	SUMP	12" X 12" X 12" W/SUMP PUMP & GRATE
J	CONCRETE SUPPORT BLOCKING	
K	6" MIN. FLANGE ADAPTOR	CEMENT LINED
L	4" X 6" FLANGED REDUCER (IF REQ'D)	CEMENT LINED
M	6" FLANGED STEEL SPOOL WITH 2" OUTLET	EPOXY COATED AND LINED
N	2" GATE VALVE WITH 4" NIPPLE	
O	6" GATE VALVE WITH HANDWHEEL	NON-RISING STEM
P	6" SINGLE DETECTOR CHECK VALVE	WATTS SERIES 07F O.A.E.
Q	6" COMPOUND FLOW METER (PURCHASED FROM CITY)	COMPOUND W/ STRAINER
R	6" PRESSURE REDUCING VALVE (IF REQ'D)	
S	6" MIN. D.I. PIPE (TO OUTSIDE OF VAULT)	CEMENT LINED
T	CITY WATER MAIN	
U	GATE VALVE WITH BOX	SEE W1
V	6" FLANGED SPOOL 12" LONG	CEMENT LINED
W	18" DIA. HDPE PIPE	PER PIPE SPEC.
X	RING & LID w/ 2" HOLE	D&L-2241 O.A.E.
Y	30"x30"x8" THICK CONCRETE COLLAR	
Z	2" PRESSURE REDUCING VALVE	WATTS ACV 1156115 O.A.E.

PROJECT# DATE SU1011 09/22/2017 <b>W-07A</b>	<b>BIG PLAINS WATER SSD</b> <b>STANDARD DETAILS</b> WATER METER WITH FIRE FLOW- PLAN VIEW WASHINGTON COUNTY, UTAH		BIG PLAINS WATER SSD 1777 N. Meadowlark Drive Apple Valley, Utah 84737 Phone 435-877-1190 Fax 435-877-1192
--	--	--	--

**Water Meter With Fire Flow-Profile View**

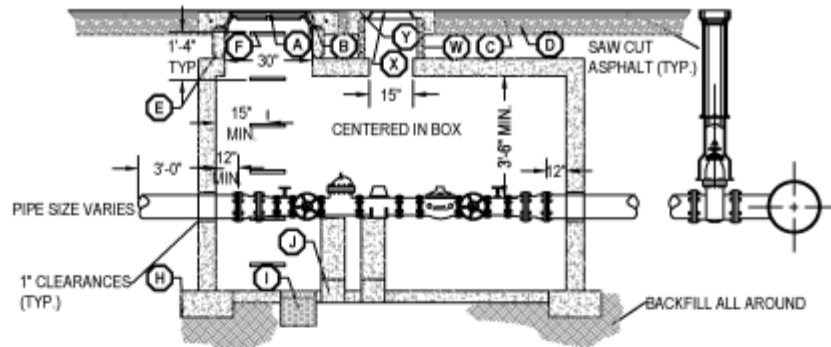

2 WATER METER WITH FIRE FLOW-PROFILE VIEW

NOTE:  
1. ALL MATERIALS PER CICWCD ENGINEERING STANDARDS UNLESS OTHERWISE SHOWN

NO.	*	ITEM	DESCRIPTION
A		MANHOLE RING AND COVER (RIBLESS)	D&L A-1180 O.A.E.
B		40 X 8" THICK CONCRETE COLLAR	W/ 40#4 BARS & FIBERS
C		3" ASPHALT MAT	
D		8" COMPACTED UNTREATED BASE	
E		GRADE RING(S)	
F		MANHOLE STEP	(M.A. INDUSTRIES INC. O.A.E.)
G		CONCRETE VAULT TOP (6'X 12')	AMCOR UV6127T O.A.E.
H		9' X 18" FOOTING W/ 3#4 BARS	
I		SUMP	12" X 12" X 12" W/SUMP PUMP & GRATE
J		CONCRETE SUPPORT BLOCKING	
K		6" MIN. FLANGE ADAPTOR	CEMENT LINED
L		X" X 6" FLANGED REDUCER (IF REQ'D)	CEMENT LINED
M		6" FLANGED STEEL SPOOL WITH 2" OUTLET	EPOXY COATED AND LINED
N		2" GATE VALVE WITH 4" NIPPLE	
O		6" GATE VALVE WITH HANDWHEEL	NON-RISING STEM
P		6" SINGLE DETECTOR CHECK VALVE	WATTS SERIES 07F O.A.E.
Q		6" COMPOUND FLOW METER (PURCHASED FROM CITY)	COMPOUND W/ STRAINER
R		6" PRESSURE REDUCING VALVE (IF REQ'D)	
S		6" MIN. D.I. PIPE (TO OUTSIDE OF VAULT)	CEMENT LINED
T		CITY WATER MAIN	
U		GATE VALVE WITH BOX	SEE W1
V		6" FLANGED SPOOL 12" LONG	CEMENT LINED
W		18" DIA. HDPE PIPE	PER PIPE SPEC.
X		RING & LID w/ 2" HOLE	D&L-2241 O.A.E.
Y		30"x30"x8" THICK CONCRETE COLLAR	
Z		2" PRESSURE REDUCING VALVE	WATTS ACV 115/6115 O.A.E.

PROJECT # SU1011    DATE 09/22/2017 <h2 style="margin: 0;">W-07B</h2>	<b>BIG PLAINS WATER SSD</b> <b>STANDARD DETAILS</b> WATER METER WITH FIRE FLOW-PROFILE WASHINGTON COUNTY, UTAH		BIG PLAINS WATER SSD 1777 N. Meadowlark Drive Apple Valley, Utah 84737 Phone 435-877-1190 Fax 435-877-1192
--	---	--	--

**Trench Detail**

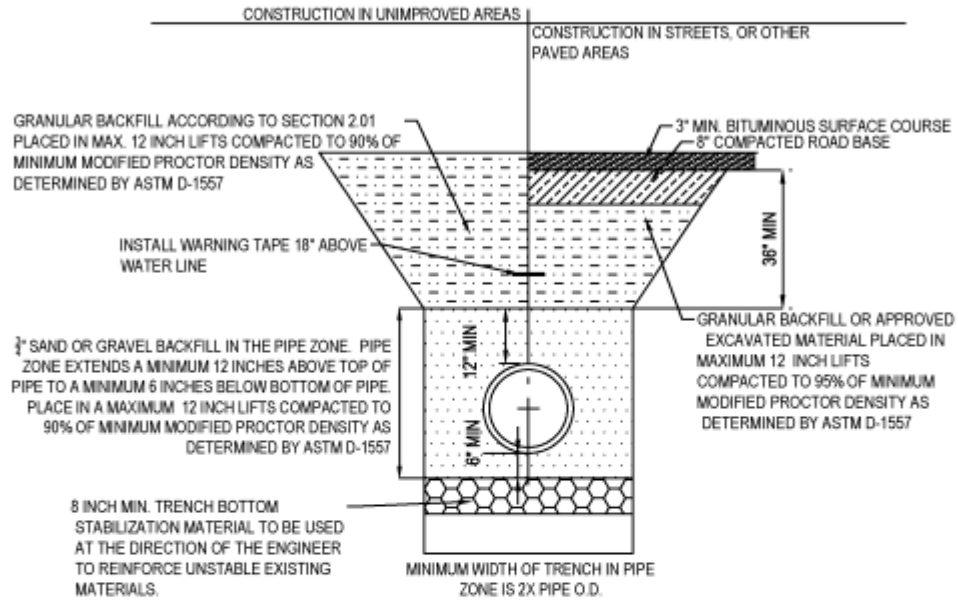

1 TRENCH DETAIL

SCALE NONE

<p>PROJECT # DATE SU1011 09/22/2017</p> <p><b>W-08</b></p>	<p><b>BIG PLAINS WATER SSD</b> <b>STANDARD DETAILS</b> TRENCH DETAIL WASHINGTON COUNTY, UTAH</p>		<p>BIG PLAINS WATER SSD 1777 N. Meadowlark Drive Apple Valley, Utah 84737 Phone 435-877-1190 Fax 435-877-1192</p>
--	--	--	---

Air Release Valve Detail

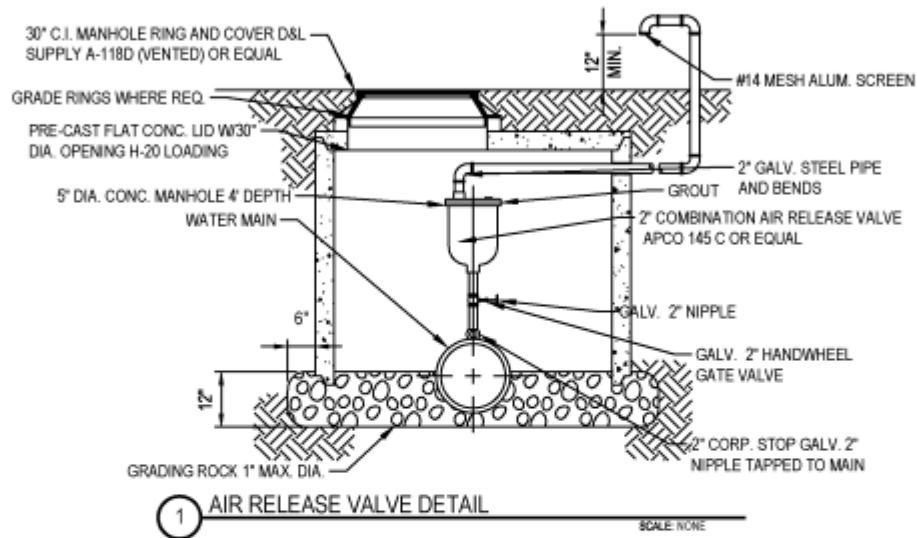

PROJECT # SU1011 DATE 09/22/2017 <b>W-09</b>	<b>BIG PLAINS WATER SSD</b> <b>STANDARD DETAILS</b> AIR RELEASE VALVE DETAIL WASHINGTON COUNTY, UTAH		BIG PLAINS WATER SSD 1777 N. Meadowlark Drive Apple Valley, Utah 84737 Phone 435-877-1190 Fax 435-877-1192
--	---	--	--

**Carrier Pipe Detail-Cross Section**



**NOTES:**

1. DOUBLE CHECK OR REDUCED PRESSURE PRINCIPLE DETECTOR ASSEMBLY TO BE APPROVED PER BPWSSSD.
2. ALL MATERIALS SHALL BE U.L. - F.M. APPROVED
3. TYPICAL LINE DRAWING. ACTUAL INSTALLATION MAY VARY WITH FIELD CONDITIONS AND FIRE DEPARTMENT REQUIREMENTS.
4. ALL JOINTS BETWEEN MAIN AND DETECTOR CHECK SHALL BE FLANGED CONNECTED.

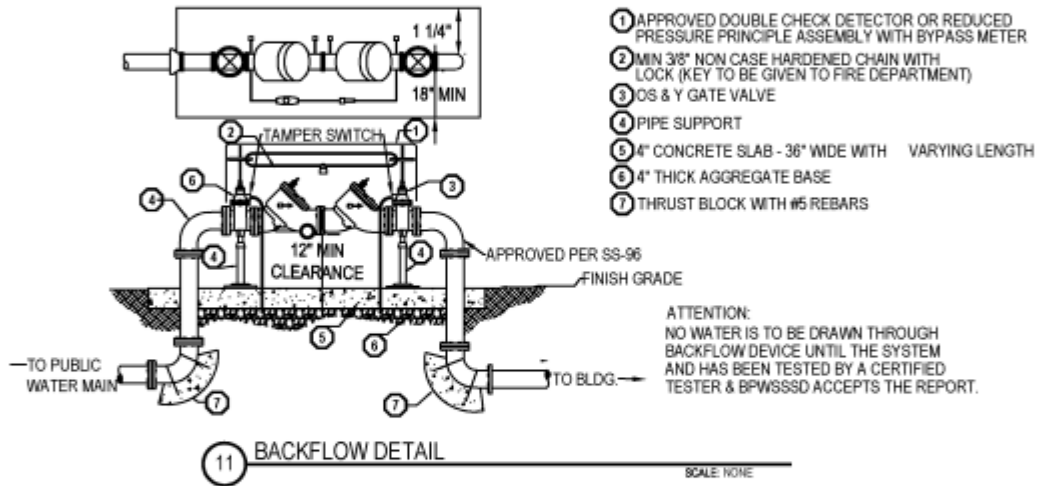

PROJECT DATE SU1011 09/22/2017  <b>W-11</b>	<b>BIG PLAINS WATER SSD</b> <b>STANDARD DETAILS</b> BACKFLOW DETAIL WASHINGTON COUNTY, UTAH		BIG PLAINS WATER SSD 1777 N. Meadowlark Drive Apple Valley, Utah 84737 Phone 435-877-1190 Fax 435-877-1192
--	--	--	--

**Pipe Fixtures-Plan View**

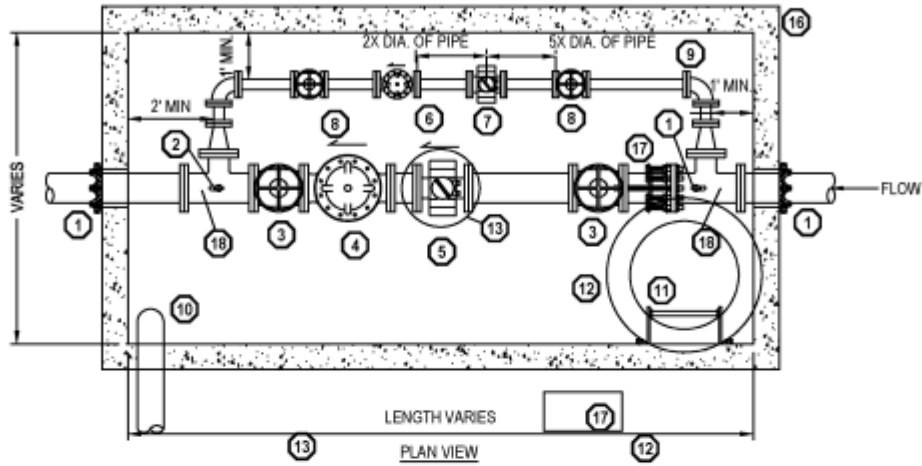

LEGEND		
NO.	ITEM	QUANTITY
1	MECHANICAL JOINT RESTRAINT (MEGALUG O.A.E.) INSTALLED FLUSH AGAINST VAULT	2
2	PRESSURE GAUGE AND HOSE BIB SEE DETAIL A	2
3	GATE VALVE (MUELLER RESILIENT O.A.E.)	2
4	CHECK VALVE OR CHECKING PRV (APCO O.A.E. OR CLA-VAL #93-01-BCSDKC)	1
5	MAGMETER (ENDRESS HAUSER O.A.E.) W/ REMOTE MOUNT	1
6	BYPASS CHECK VALVE OR CHECKING PRV (APCO O.A.E. OR CLA-VAL #93-01-ASCDKC)	1
7	BYPASS MAGMETER (ENDRESS HAUSER O.A.E.) W/ REMOTE MOUNT	1
8	BYPASS GATE VALVE (MUELLER RESILIENT O.A.E.)	1
9	FLANGED BYPASS MAXIMUM OF 2 SIZES SMALLER THAN MAIN	1
10	GALVANIZED STEEL/HDPE LADDER (RUNGS SPACED 9" APART O.C.)	1
11	30" MANHOLE ACCESS (D&L A-1180 COVER O.A.E.)	1
12	RING & LID (D&L-2241 O.A.E.)	1
13	PIPE SUPPORT (TYP.)	3
14	12" x 12" x 2" CONCRETE BLOCK (TYP.)	3
15	ENGINEERED PRECAST CONCRETE VAULT, SIZE TO BE DETERMINED BY BPWSSSD	1
16	RTU PEDESTAL SEE DETAIL D	1
17	TIE ROD STYLE DISMANTLING JOINT (ROMAC DJ400 O.A.E.)	1
18	THREADED SUBMERSIBLE TRANSDUCER 0-150 PSI RANGE (KPSI O.A.E.)	2

1 PIPE FIXTURES: PLAN VIEW SCALE: NONE

PROJECT DATE SU1011 09/22/2017 <b>W-12A</b>	<b>BIG PLAINS WATER SSD</b> <b>STANDARD DETAILS</b> PIPE FIXTURES PLAN VIEW WASHINGTON COUNTY, UTAH		BIG PLAINS WATER SSD 1777 N. Meadowlark Drive Apple Valley, Utah 84737 Phone 435-877-1190 Fax 435-877-1192
---	--	--	--

**Assorted Details**

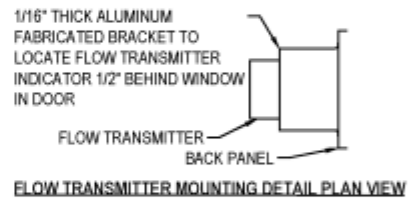
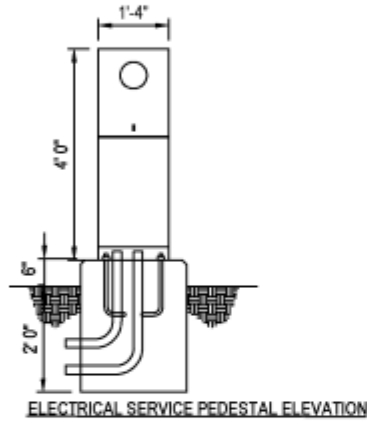
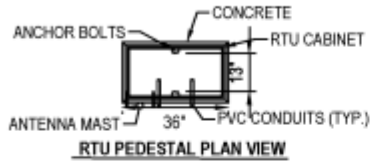

1 ASSORTED DETAILS SCALE: 1

PROJECT # SU1011 DATE 09/22/2017 <b>W-12B</b>	<b>BIG PLAINS WATER &amp; SEWER SSD</b> <b>STANDARD DETAILS</b> ASSORTED DETAILS WASHINGTON COUNTY, UTAH		BIG PLAINS WATER SSD 1777 N. Meadowlark Drive Apple Valley, Utah 84737 Phone 435-877-1190 Fax 435-877-1192
--	---	--	--

**Meter Pedestal For Riser Connection**

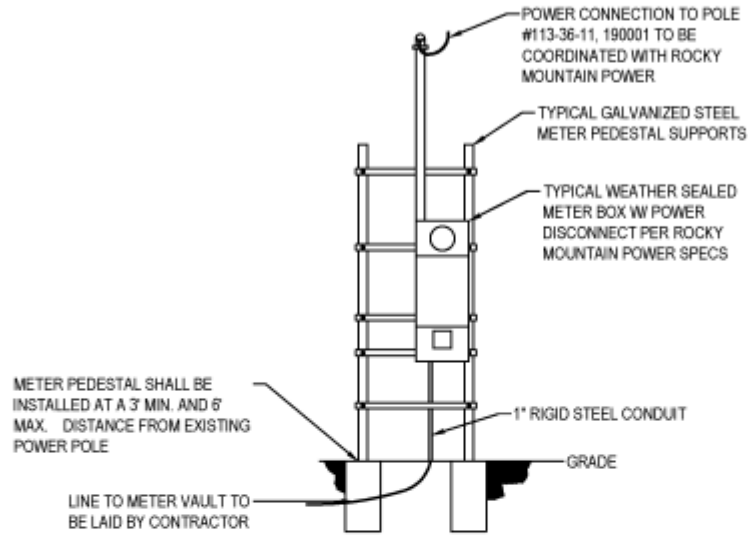

1 METER PEDESTAL FOR RISER CONNECTION  
SCALE: NONE

PROJECT # SU1011 DATE 09/22/2017 <b>W-12C</b>	<b>BIG PLAINS WATER SSD</b> <b>STANDARD DETAILS</b> METER PEDESTAL FOR RISER CONNECTION WASHINGTON COUNTY, UTAH		BIG PLAINS WATER SSD 1777 N. Meadowlark Drive Apple Valley, Utah 84737 Phone 435-877-1190 Fax 435-877-1192
--	--	--	--

**RTU Pedestal Elevations-Front And Back**

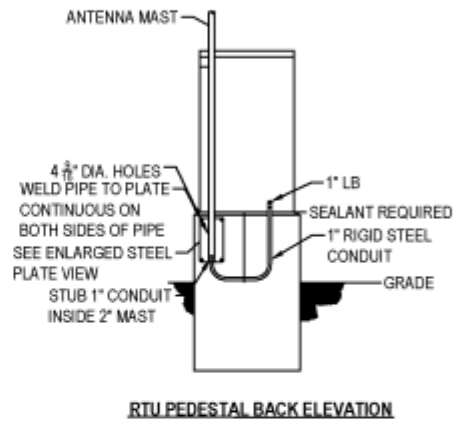
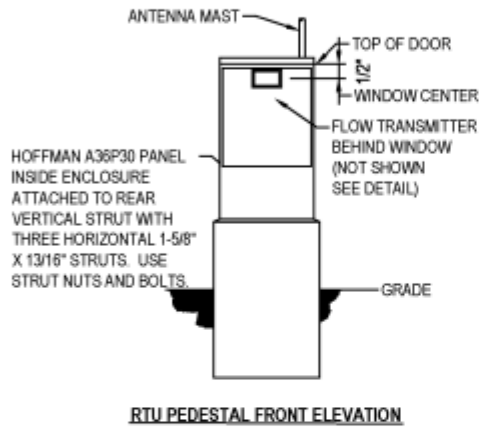

1 RTU PEDESTAL ELEVATIONS- FRONT AND BACK SCALE NONE

<p>PROJECT # DATE SU1011 09/22/2017</p> <p><b>W-12D</b></p>	<p><b>BIG PLAINS WATER SSD</b>  <b>STANDARD DETAILS</b>  RTU PEDESTAL ELEVATIONS  WASHINGTON COUNTY, UTAH</p>		<p>BIG PLAINS WATER SSD  1777 N. Meadowlark Drive  Apple Valley, Utah 84737  Phone 435-877-1190  Fax 435-877-1192</p>
---	---	--	---

RTU Pedestal Side Elevation

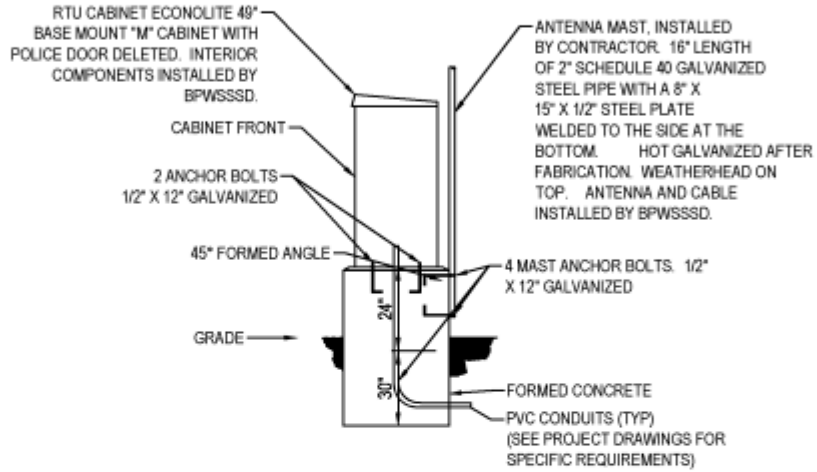

1 RTU PEDESTAL SIDE ELEVATION SCALE: NONE

PROJECT # SU1011 DATE 09/22/2017 <b>W-12E</b>	<b>BIG PLAINS WATER SSD</b> <b>STANDARD DETAILS</b> RTU PEDESTAL SIDE ELVATION WASHINGTON COUNTY, UTAH		BIG PLAINS WATER SSD 1777 N. Meadowlark Drive Apple Valley, Utah 84737 Phone 435-877-1190 Fax 435-877-1192
--	---	--	--

Vent Pipe Side Penetration

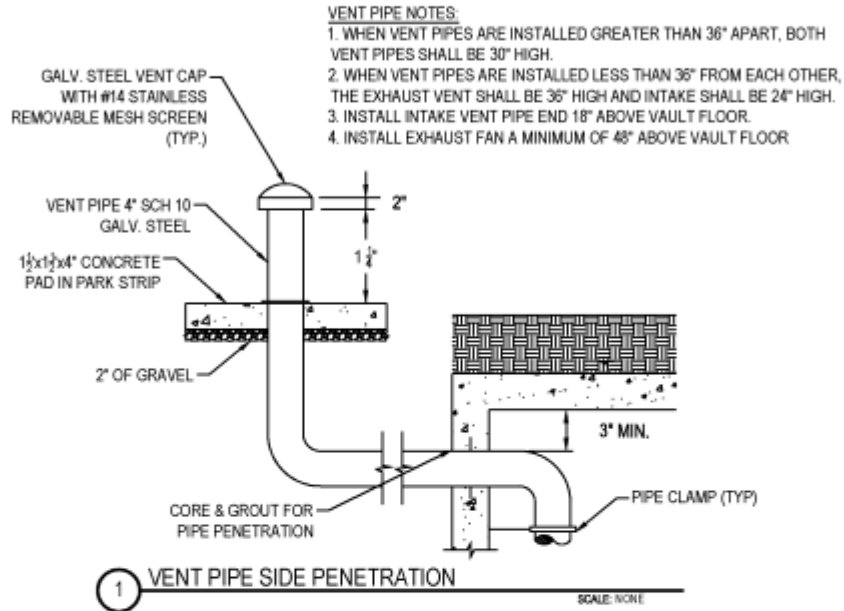

PROJECT # SU1011 DATE 09/22/2017 <b>W-12F</b>	<b>BIG PLAINS WATER SSD</b> <b>STANDARD DETAILS</b> VENT PIPE SIDE PENETRATION WASHINGTON COUNTY, UTAH		BIG PLAINS WATER SSD 1777 N. Meadowlark Drive Apple Valley, Utah 84737 Phone 435-877-1190 Fax 435-877-1192
---	---	--	--

**Pipe Fixtures-Plan And Profile View**

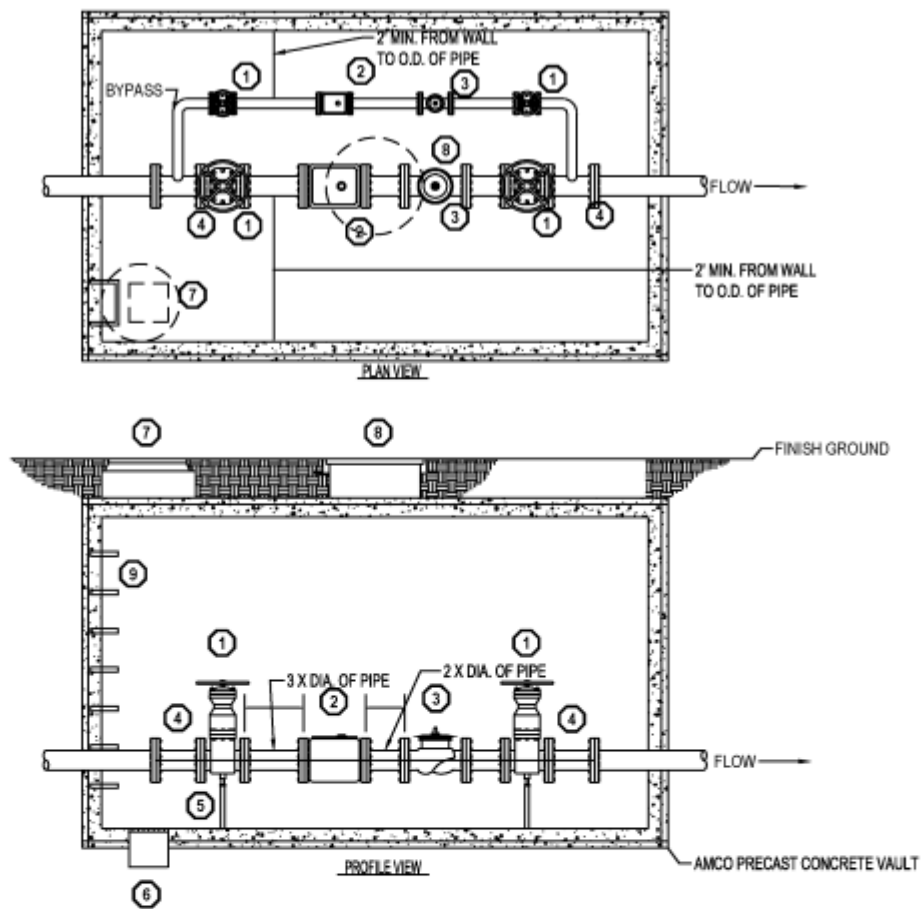

LEGEND	
NO.	ITEM
1	GATE VALVE (MULLER RESILIENT SEAT OR APPROVED EQUAL)
2	MAGMETER (ENDRESS HAUSER OR APPROVED EQUAL)
3	CHECK VALVE (APCO OR APPROVED EQUAL)
4	TEE
5	PIPE SUPPORTS
6	12" X 12" X 12" SUMP W/ PUMP & GRATE
7	24" MIN. MANHOLE ACCESS W/ CAST IRON LID
8	24" TO 36" SECONDARY MAINTENANCE ACCESS (DAL 1428 COVER OR APPROVED EQUAL)
9	GALVANIZED STEEL HOPE LADDER (RUNGS SPACED 9' APART O.C.)

- NOTE:
1. CHECK VALVE MAY BE REPLACED BY CHECKING PRV IF NECESSARY.
  2. LINE IN VAULT MAY BE REDUCED TO DECREASE THE SIZE OF METER AS APPROVED BPWSSD.
  3. A MINIMUM OF (3) PIPE SUPPORTS TO BE PLACED UNDER MAIN AND BYPASS LINES
  4. BYPASS SHALL BE A MAXIMUM OF 2 SIZES SMALLER THAN MAINLINE UNLESS APPROVED BY BPWSSD

1 PIPE FIXTURES: PLAN & PROFILE VIEW SCALE: NONE

PROJECT # SU1011 DATE 09/22/2017 <b>W-12G</b>	<b>BIG PLAINS WATER SSD</b> <b>STANDARD DETAILS</b> PIPE FIXTURES: PLAN & PROFILE VIEW WASHINGTON COUNTY, UTAH		BIG PLAINS WATER SSD 1777 N. Meadowlark Drive Apple Valley, Utah 84737 Phone 435-877-1190 Fax 435-877-1192
--	---	--	--

Pipe Fixtures-Profile View

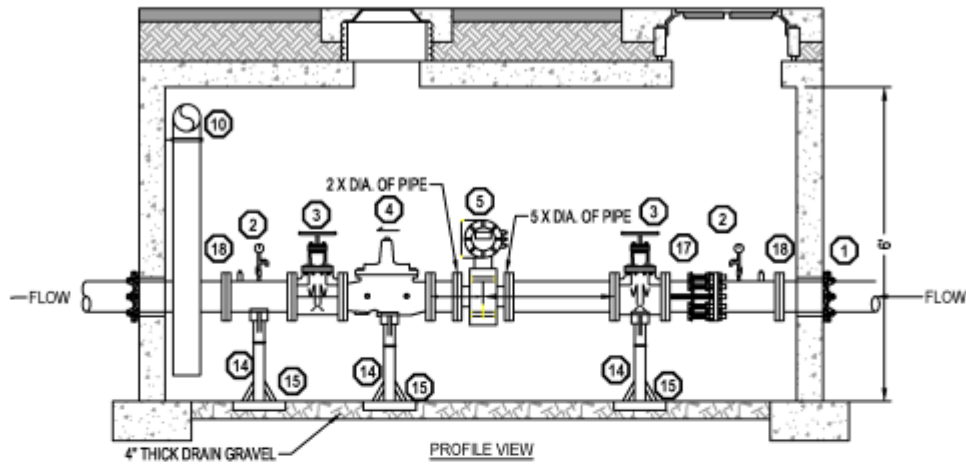

LEGEND		
NO.	ITEM	QUANTITY
1	MECHANICAL JOINT RESTRAINT (MEGALUG O.A.E) INSTALLED FLUSH AGAINST VAULT	2
2	PRESSURE GAUGE AND HOSE BIB SEE DETAIL A	2
3	GATE VALVE (MUELLER RESILIENT O.A.E)	2
4	CHECK VALVE OR CHECKING PRV (APCO O.A.E OR CLA-VAL #93-01-BCSDKC)	1
5	MAGMETER (ENDRESS HAUSER O.A.E) W/ REMOTE MOUNT	1
6	BYPASS CHECK VALVE OR CHECKING PRV (APCO O.A.E OR CLA-VAL #93-01-ASCDKC)	1
7	BYPASS MAGMETER (ENDRESS HAUSER O.A.E) W/ REMOTE MOUNT	1
8	BYPASS GATE VALVE (MUELLER RESILIENT O.A.E)	1
9	FLANGED BYPASS MAXIMUM OF 2 SIZES SMALLER THAN MAIN	1
10	GALVANIZED STEEL HDPE LADDER (RUNGS SPACED 9" APART O.C.)	1
11	30" MANHOLE ACCESS (D&L A-1180 COVER O.A.E)	1
12	RING & LID (D&L-2241 O.A.E)	1
13	PIPE SUPPORT (TYP.)	3
14	12" x 12" x 2" CONCRETE BLOCK (TYP.)	3
15	ENGINEERED PRECAST CONCRETE VAULT. SIZE TO BE DETERMINED BY BPWSSSD	1
16	RTU PEDESTAL SEE DETAIL D	1
17	TIE ROD STYLE DISMANTLING JOINT (ROMAC DJ400 O.A.E)	1
18	THREADED SUBMERSIBLE TRANSDUCER 0-150 PSI RANGE (KPSI O.A.E)	2

1 PIPE FIXTURES: PROFILE VIEW SCALE: NONE

PROJECT# DATE SU1011 09/22/2017 <b>W-12H</b>	<b>BIG PLAINS WATER SSD</b> <b>STANDARD DETAILS</b> PIPE FIXTURES: PROFILE VIEW WASHINGTON COUNTY, UTAH		BIG PLAINS WATER SSD 1777 N. Meadowlark Drive Apple Valley, Utah 84737 Phone 435-877-1190 Fax 435-877-1192
--	--	--	--

**Pressure Gauge W/Hose Bib**

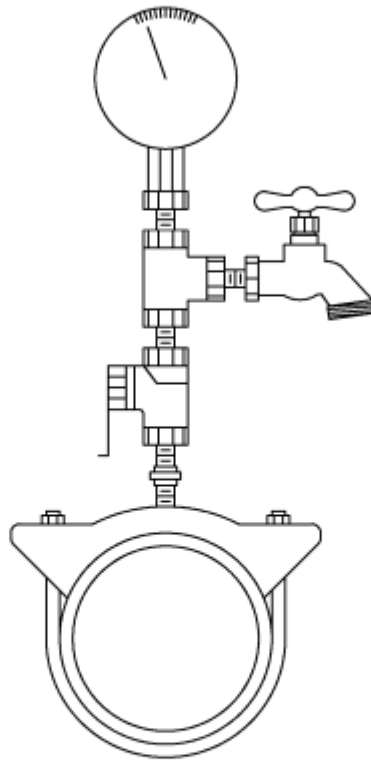

PRESSURE GAUGE W/ HOSE BIB

<small>PROJECT# DATE</small> SU1011 09/22/2017	<b>BIG PLAINS WATER SSD</b> <b>STANDARD DETAILS</b> PRESSURE GAUGE W/ HOSE BIB WASHINGTON COUNTY, UTAH		<b>BIG PLAINS WATER SSD</b> 1777 N. Meadowlark Drive Apple Valley, Utah 84737 Phone 435-877-1190 Fax 435-877-1192
---	---	--	---

**Typical Cable Tool Well Section**

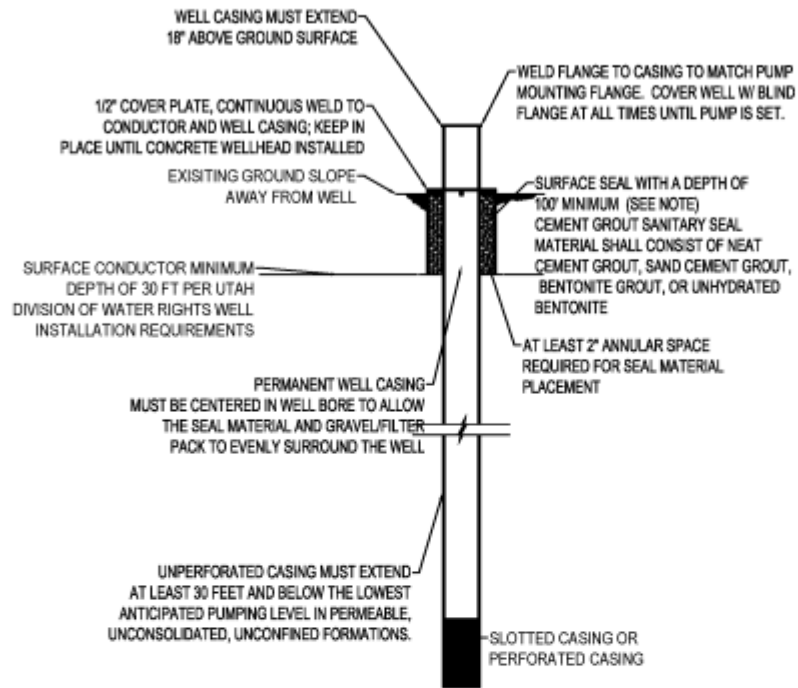

**NOTE**  
THE SURFACE SEAL MUST BE PLACED FROM GROUND SURFACE TO A MINIMUM DEPTH OF 30 FEET AND AT LEAST 5 FEET INTO A CONFINING UNIT ABOVE THE WATER PRODUCTION ZONE IN UNCONSOLIDATED FORMATIONS STRATIFIED WITH CLAY, OR AT LEAST 5 FEET INTO COMPETENT CONSOLIDATED FORMATIONS.

1 TYPICAL CABLE TOOL WELL SECTION

SCALE: NONE

PROJECT # SU1011 DATE 09/22/2017  <b>W-14</b>	<b>BIG PLAINS WATER SSD</b> <b>STANDARD DETAILS</b> TYPICAL CABLE TOOL WELL SECTION WASHINGTON COUNTY, UTAH		BIG PLAINS WATER SSD 1777 N. Meadowlark Drive Apple Valley, Utah 84737 Phone 435-877-1190 Fax 435-877-1192
---	--	--	--

**Typical Screened/Gravel Packed Well Section**

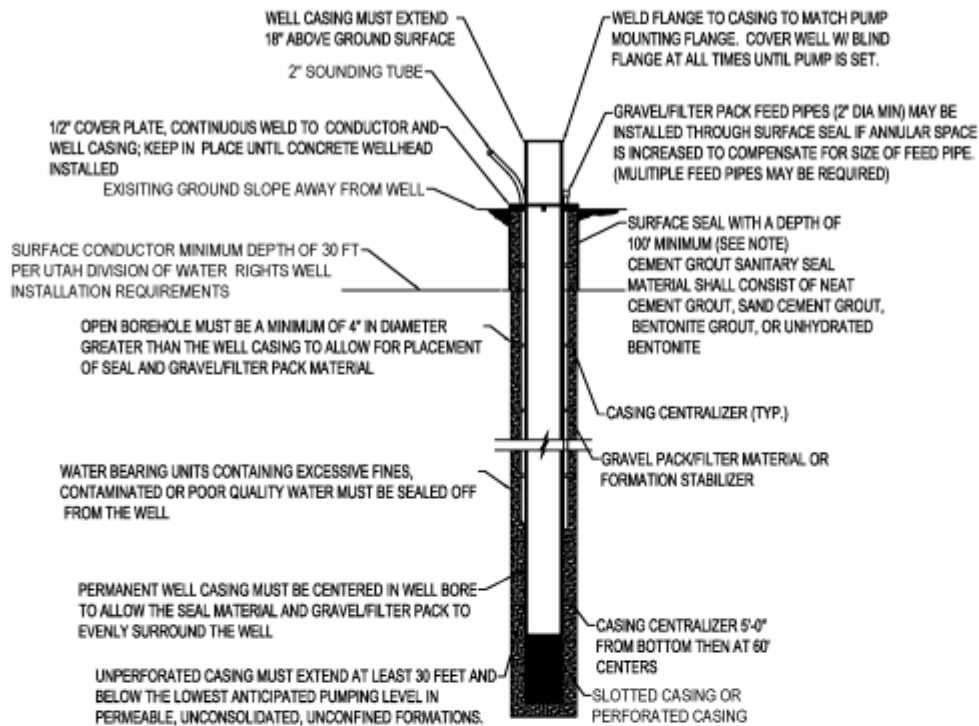

**NOTE**

THE SURFACE SEAL MUST BE PLACED FROM GROUND SURFACE TO THE DEEPEST OF THE FOLLOWING OPTIONS AS APPLICABLE:

- 1) A MINIMUM DEPTH OF 100 FEET AND FOR A THICKNESS OF AT LEAST 30 FEET THROUGH A PROTECTIVE CLAY LAYER (R309-600-R(1)(V), R309-204-6(6)(i))
- 2) FROM STATIC WATER LEVEL TO GROUND SURFACE IN UNCONSOLIDATED FORMATIONS (NO CONFINING UNIT);
- 3) AT LEAST 5 FEET INTO A CONFINING UNIT IN CLAY STRATIFIED UNCONSOLIDATED FORMATIONS; AND
- 4) AT LEAST 5 FEET INTO COMPETENT CONSOLIDATED FORMATIONS.

1 TYPICAL SCREENED/GRAVEL PACKED WELL SECTION

SCALE: NONE

PROJECT # SU1011 DATE 09/22/2017 <b>W-15</b>	<b>BIG PLAINS WATER SSD</b> <b>STANDARD DETAILS</b> TYPICAL SCREENED/GRAVEL PACKED WELL SECTION WASHINGTON COUNTY, UTAH		BIG PLAINS WATER SSD 1777 N. Meadowlark Drive Apple Valley, Utah 84737 Phone 435-877-1190 Fax 435-877-1192
--	--	--	--

**Hot Tap Plan View And Section View**

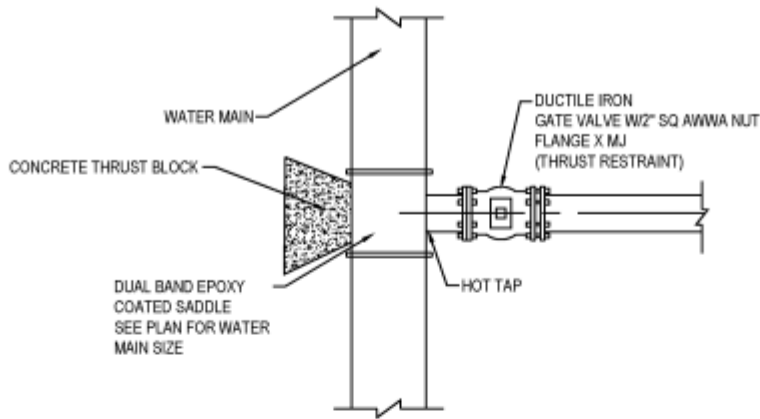

1 HOT TAP PLAN VIEW SCALE: NONE

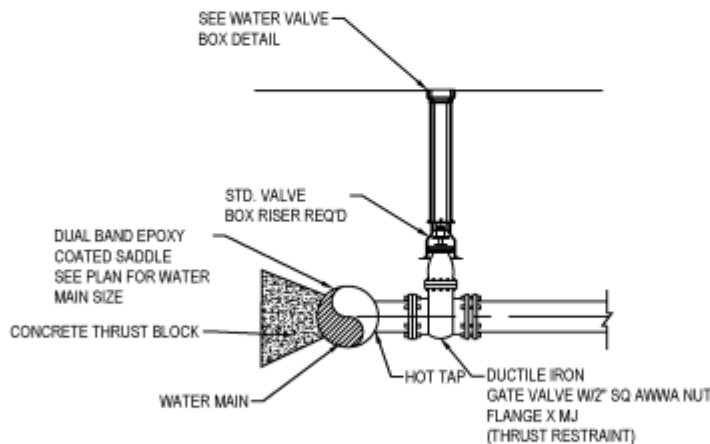

2 HOT TAP SECTION VIEW SCALE: NONE

PROJECT # SU1011 DATE 09/22/2017 <b>W-16</b>	<b>BIG PLAINS WATER SSD</b> <b>STANDARD DETAILS</b> HOT TAP WASHINGTON COUNTY, UTAH		BIG PLAINS WATER SSD 1777 N. Meadowlark Drive Apple Valley, Utah 84737 Phone 435-877-1190 Fax 435-877-1192
--	--	--	--

**01.17.000 Penalties And Violations**

A. Notwithstanding individual penalties stated elsewhere in this policy, the following policy shall apply to this entire manual as follows:

1. A maximum criminal penalty for the violation of any policy may be imposed a fine not to exceed the maximum class B misdemeanor or fine under the Utah Code Annotated Section 76-3-301 or by a term of imprisonment up to six (6) months, or both the fine and term imprisonment.

2. Terms of imprisonment. A person who has been convicted of a misdemeanor may be sentenced to imprisonment as follows:
  - a. In the case of a class B misdemeanor, for a term not exceeding six (6) months.
  - b. In the case of a class C misdemeanor, for a term not exceeding ninety (90) days.
  
3. Infractions:
  - a. A person convicted of an infraction may not be imprisoned but may be subject to a fine, forfeiture and disqualification, or any combination.
  - b. Whenever a person is convicted of an infraction and no punishment is specified, the person, the person may be fined as for a class C misdemeanor.
  
4. Fines. A person convicted of an offense may, in addition to any term of imprisonment imposed, be sentenced to pay a fine not to exceed:
  - a. Class B Misdemeanor: One thousand dollars (\$1,000.00) when the conviction is of a class B misdemeanor conviction; and
  - b. Class C Misdemeanor; Infraction: Seven hundred fifty dollars (\$750.00) when the conviction is of a class C misdemeanor conviction or infraction conviction.
  
5. Fines of Corporations: The sentence to pay a fine, when imposed upon a corporation, association, partnership, or governmental instrumentality for an offense defined in this policy for which no special corporate fine is specified, shall be to pay an amount fixed by the court, not exceeding:
  - a. Class B Misdemeanor: Five thousand dollars (\$5,000.00) when the conviction is for a class B misdemeanor conviction; and
  - b. Class C Misdemeanor; Infraction: One thousand dollars (\$1,000.00) when the conviction is for a class C misdemeanor conviction or for an infraction conviction.
  
6. Continuing Violation: In all instances where the violation of this policy is a continuing violation, a separate offense shall be deemed committed on each day during or on which the violation occurs or continues to occur.

**[01.20.000 Appendix A Schedule Of Water Rates, Fees, And Charges](#)**

[01.20.010 Residential](#)

[01.20.020 Commercial](#)

[01.20.030 Bulk Meter](#)

[01.20.040 Cost Of Services](#)

**01.20.010 Residential**

Residential Standby Fee: \$49/month

Residential Base Fee: \$49/month

Residential Usage Fees:

Gallons Used	Charge/1,000 Gal	Total
0-base/standby		\$49.00

0-5,000	\$1.50	Calculated based on usage
5,001-12,000	\$1.75	Calculated based on usage
12,001-25,000	\$2.00	Calculated based on usage
25,001-35,000	\$2.25	Calculated based on usage
35,001-45,000	\$2.50	Calculated based on usage
45,001+	\$2.75	Calculated based on usage

Residential Impact Fee (3/4 in Connection): \$12,000

Connection Fee Deposit by Meter Size:

- 3/4-inch Connection Fee: \$1,600
- 1-inch Connection Fee: \$1,900
- 1.5-inch Connection Fee: \$2,900
- 2-inch or Larger Connection Fee: Quoted Upon Request

Actual cost of the connection depending on the size of meter required.

One (1) acre foot of municipal category water rights must be deeded to the District.

**01.20.020 Commercial**

Commercial 1-inch meter base/standby rate:

Commercial 1.5-inch meter base/standby rate:

Commercial 2-inch meter base/standby rate:

Commercial 3-inch meter base/standby rate:

Commercial 4-inch meter base/standby rate:

Commercial Usage Fees: \$1.50 per 1,000 Gallons

Commercial Impact Fee: (Based on connection diameter-see table below. Appropriate acre feet of water of municipal category water rights must be deeded to the District)

Connection Diameter (in)	ERC's	Impact Fee Amount
3/4	1	\$12,000
1	3	\$15,000
1.5	5	\$21,000
2	8	\$27,000
3	10	\$39,000

Commercial Retail Connection Fee: Actual cost of the connection depending on the size of meter required.

### **01.20.030 Bulk Meter**

Bulk Meter Usage Fees:

\$49 meter fee for usage up to five days, with a \$5.00 charge for each additional day the meter is out.

The water usage cost is \$4.00/1,000 gallons used.

The meter must be read at least every 30 days.

A \$1,000 meter deposit is required.

There will be a \$250 additional charge for late (greater then five (5) days and thirty (30) days.

### **01.20.040 Cost Of Services**

#### COST OF SERVICES

- Application Processing Fee \$125
- Well Permit Fee \$250

- Engineering Actual Cost
- Inspections \$60/Hour
- Will Serve Letters \$75
- Call-Outs \$60 First Hour Minimum / \$80 Additional Hours
- Equipment Actual Cost
- Late Notice Fee \$5
- Service Restoration Fee \$50
- Interest Charges 5%/Month

**01.21.000 Appendix B Acknowledgement Of Water Supply**

APPENDIX B

Big Plains Water SSD  
 1777 N Meadowlark Dr  
 Apple Valley UT 84737  
 T: 435.877.1190 | F: 435.877.1192  
 www.applevalleyut.gov

I/We, \_\_\_\_\_ am/are the applicant(s) of the application known as \_\_\_\_\_ located on parcel(s) \_\_\_\_\_ within the Town of Apple Valley, Washington County, Utah.

By my/our signatures(s) below, I/we do hereby acknowledge and agree to the following:

1. Approval of a development application by the Town does not guarantee that sufficient water will be available to serve the zone, project, subdivision, or development for which this application is being submitted; and
2. Prior to receiving approval for the application, the applicant shall be required by the Town of Apple Valley to provide a preliminary Will Serve letter from the Big Plains Water Special Service District ("District") which verifies the conditions required to provide services to the project, subdivision, or development; and
3. The applicant assumes the entire risk of water availability for the project, subdivision or development and/or application.

Signature(s):

Name	Applicant/Owner	Date
Name	Applicant/Owner	Date
Name	Applicant/Owner	Date

State of \_\_\_\_\_ )  
 )§  
 County of \_\_\_\_\_ )

On this \_\_\_\_\_ day of \_\_\_\_\_, in the year 20\_\_\_\_, before me, \_\_\_\_\_ a notary public, personally appeared \_\_\_\_\_, proved on the basis of satisfactory evidence to be the person(s) whose name(s) (is/are) subscribed to this instrument, and acknowledged (he/she/they) executed the same.

Witness my hand and official seal.

\_\_\_\_\_

(notary signature)

(seal)