

AN ORDINANCE TO AMEND CERTAIN SECTIONS OF THE UNIFIED DEVELOPMENT ORDINANCE

BE IT ORDAINED by the Town Council of the Town of Apex as follows:

Section 1. Section 8.6 of the Unified Development Ordinance is amended to read as follows with additions shown as bold underlined text and deletions shown as struck-through text:

8.6 EXTERIOR LIGHTING

8.6.1 Purpose and Intent

The purpose of this Ordinance is to provide regulations for outdoor lighting that will:

- A) Permit the use of outdoor lighting that will heighten nighttime safety, utility, security, productivity, enjoyment, and commerce.
- B) Minimize adverse offsite impacts of lighting such as light trespass and obtrusive light.
- C) Curtail light pollution.
- D) Help protect wildlife and habitat from the adverse effects of night lighting.
- E) Conserve energy and resources.

~~The provision of outdoor lighting heightens nighttime safety and visibility, and is used to enhance the security of property and people. Lighting should be provided in areas of heavy vehicle and pedestrian use, and areas that are dangerous if unlit such as stairs, intersections, or changes in grade. It is important to set clear guidelines so that lighting~~
Outdoor lighting should adequately serves the site while minimizing negative impacts on surrounding properties.

8.6.2 Lighting Plan

~~Any development~~ **Site Plan and Nonresidential Master Subdivision Plan** that proposes exterior lighting shall include a detailed exterior lighting plan as part of the plan submission. This plan shall include:

- A) Specifications for the lighting fixtures such as: type of unit (cutoff, ~~non-cutoff~~, glare shields, etc.), **BUG rating**, lamps (~~wattage~~ **lumens**, etc.), correlated color temperature of lamps (Kelvin), electrical load requirements, utility company involved, method of wiring, routing/location of lines, location of lights, and mounting heights. **All lighting fixtures proposed shall be high efficiency and possess LED lamp technology.**
- B) An isofootcandle plan that shows typical foot-candle contours or a point photometric grid that indicates foot-candle levels measured at grade across the site. A point photometric plan is required for Minor and Major Site Plans with more than two (2) light poles. Other information such as: maximum, average, and minimum site foot-candles and uniformity ratio (average/minimum) should also be included. Foot-candle levels shall be shown at initial **published levels for each fixture.**

- C) Cross-sections of all lighted perimeter areas immediately adjacent to existing residential properties indicating how all exterior lighting (site and building mounted lighting) will be designed to limit spillover light and control off-site glare (see Sec. 8.6.4.D-4). A cross-section ~~must~~ **shall** be provided for each adjoining single-family residential property. Where the developing site adjoins multi-family residential property, a typical cross-section must be provided at 100-foot intervals along the common property line. The cross-sections must accurately represent existing site topography of the residential properties, sections of the residential units, and proposed topography and site/architectural elements (buildings, retaining walls, lights, landscape screening, etc.) of the developing site (see Sec. 8.6.4.A). **It is not necessary to produce or overlay foot-candle readings on the cross-section drawings. The intent is to identify areas where fixture placement may introduce potential glare and require mitigation through shielding if mitigation is not provided through protected or proposed vegetation.**

- D) Plan certification by a licensed lighting professional holding the PE, LC, or CLEP certification or similar certification that indicates proficiency in the design of outdoor lighting, a lighting manufacturer, or the local electric utility. The certification must verify that the plans meet the Town’s design requirements and illumination standards.

8.6.3 Illumination Standards

- A) The tables below set forth standards for lighting intensity based upon the land use or activity involved. Values are presented in initial foot-candles measured at grade. Site lighting shall not exceed these initial average foot-candle levels. Average values must be calculated using the levels found within the lighted area; for example, a parking lot must be calculated using the levels found within the curb to curb or paved parking area only. **The developer shall provide the name of the software program used to determine the lighting parameters as well as the summary sheets indicating the average illuminance and uniformity ratios achieved in their layouts.**

Table 8.6-1: Lighting Standards for General Parking with Pedestrian Areas (initial foot-candles)

- Multi-family residential or condominium (stacked flat)	<u>4.0</u>	8/1
- Retail	<u>4.0</u>	4/1
Office Industrial Educational Cultural, civic, and recreational Church or place of worship Townhomes and other attached residential	<u>2.0</u>	4/1

Table 8.6-2: Other Exterior Lighting Standards (initial foot-candles)

*Vital locations (entry/exit doors, service areas, ATMs, bicycle parking, etc.)	5.0	4/1
Bicycle parking	3.0	4/1
Sidewalks	1.0	4/1
Vehicular use area other than parking (service areas, drives and approach ways, private access roads, etc.)	1.0	4/1
Storage yards	4.0	4/1
Loading/unloading docks and platforms	15.0	4/1
Auto sales yard/enclosed outdoor display	10.0	8/1
General recreational areas (fields**, playgrounds, courts**, pools)	10.0	4/1

*Average initial levels for vital locations shall be generally based on an area 10 feet by 10 feet or the limits of the specific area.

**See 8.6.4.I-J for specific exceptions to this standard.

B) Color Temperature

The correlated color temperature (CCT) of lamps in exterior lighting shall not exceed 3,500 Kelvins. Athletic field lighting shall be exempt from this requirement.

8.6.4 Design Requirements

Exterior lighting, such as that used in and around buildings, recreation areas, parking lots, and signs, shall be designed to prevent the excessive spillover of light onto adjacent properties. It shall also be designed to protect against glare onto public rights-of-way thereby impairing the vision of motorists and adversely impacting adjoining properties. All exterior lighting shall be shielded from adjacent properties by existing vegetation, thick evergreen vegetated buffers, berms, walls, or fences, and/or the use of directional lighting, lighting shields, special fixtures, timing devices, appropriate light intensities, luminaries, and mountings at appropriate heights. External and/or internal shields are required on all lights in vehicular use areas and lights mounted to buildings where they are immediately adjacent to residential uses (such as along the edges of parking lots or mounted to the rear of buildings close to residential uses). All outdoor lighting shall conform to the following design standards:

A) Mounting Heights

Outdoor lighting fixtures shall be designed, located and mounted at heights shown to be appropriate in cross-section (see also Sec. 8.6.2.C), but in no case shall be greater than:

- 1) ~~18 feet above grade for non-cutoff lights (see Sec. 8.6.4.D.2);~~
- 2) **1) 35 feet above grade for full cutoff fixtures (see Sec. 8.6.4.D.3), except as stated elsewhere in this Section.** The height for full cutoff lights fixtures along the perimeter of non-residential sites where they are immediately adjacent to adjoining residential properties shall be designed based on cross-sections as required by Sec. 8.6.2.C). **House-side shields are required based on cross-sections to avoid glare produced by lamp**

sources that is visible from the edge of residential building(s) and not fully shielded by existing or proposed vegetation shown on the landscape plan.

- 3-2) Mounting height is measured from the finished grade or surface and includes the total height of the fixture, pole, and any base or other supporting structure required to mount the light(s).

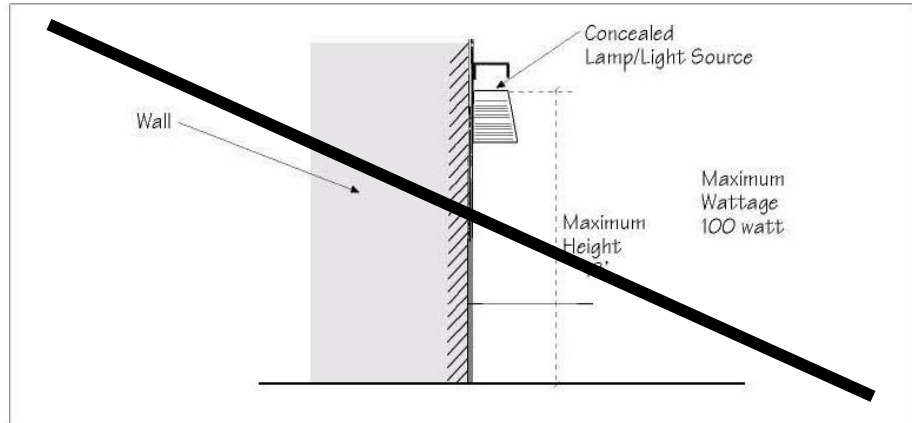

WALL-PACK LIGHT FIXTURES

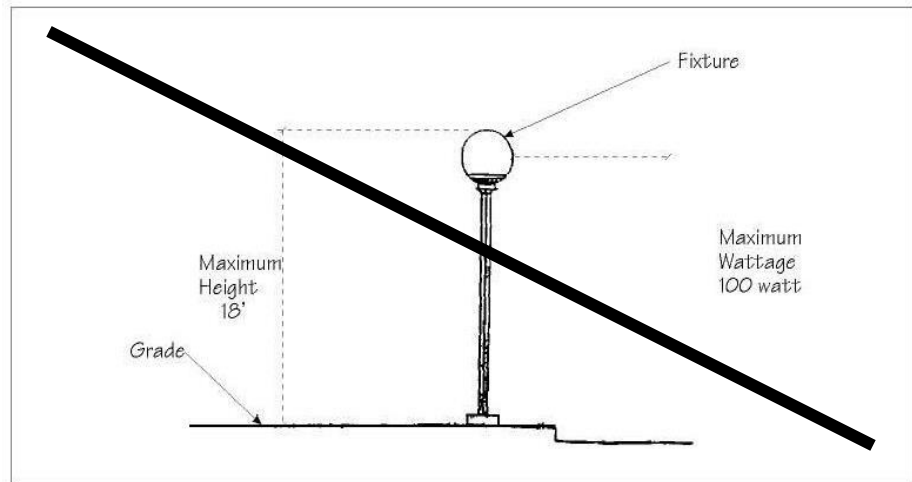

NON-CUTOFF LIGHT FIXTURE

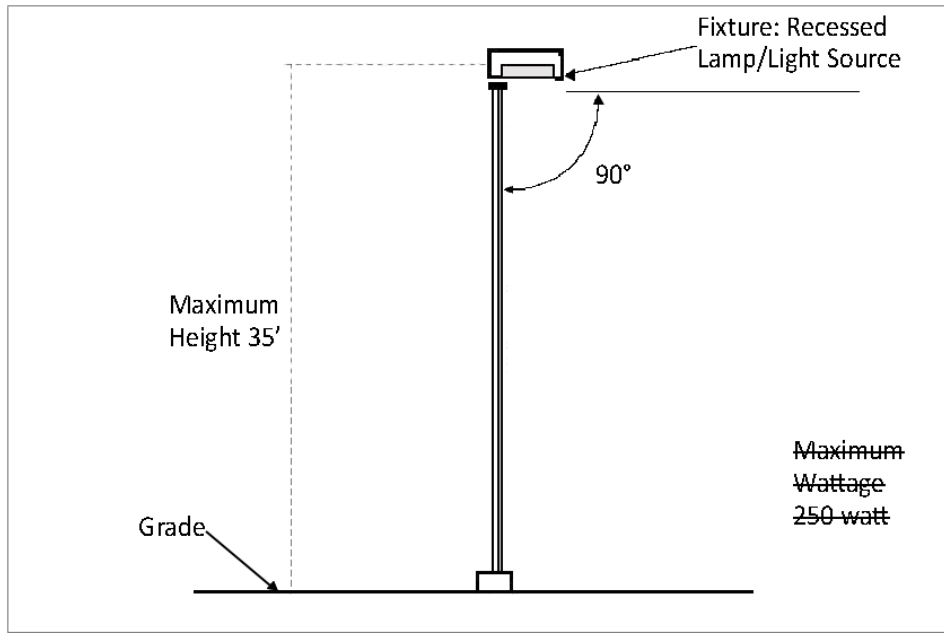

Full Cutoff Pole Mounted Fixture

Figure 8.6.4.A Mounting Height for Pole Mounted Fixture

B) *Location*

- 1) All outdoor lighting fixtures shall be located a minimum of 10 feet from a property or right-of-way line, and should be kept out of and at least two (2) feet away from any required perimeter or streetscape buffer, and tree save area.
- 2) The layout of lighting shall be designed so that poles do not interfere with other elements of the approved site such as trees, landscaping, and parking. ~~In general, poles should~~ **shall** be kept at least 20 feet away from the trunk of any large type tree and at least 10 feet away from the trunk of any small type tree, **except in cases where the Planning Director determines it is not reasonable and practical.**
- 3) Lighting for outdoor display areas, such as auto dealerships, must be located inside the illuminated area or no more than 10 feet away from the outside edge of the illuminated area so that the amount of direct glare and the visual field of view does not present a safety hazard to the passing motorist.

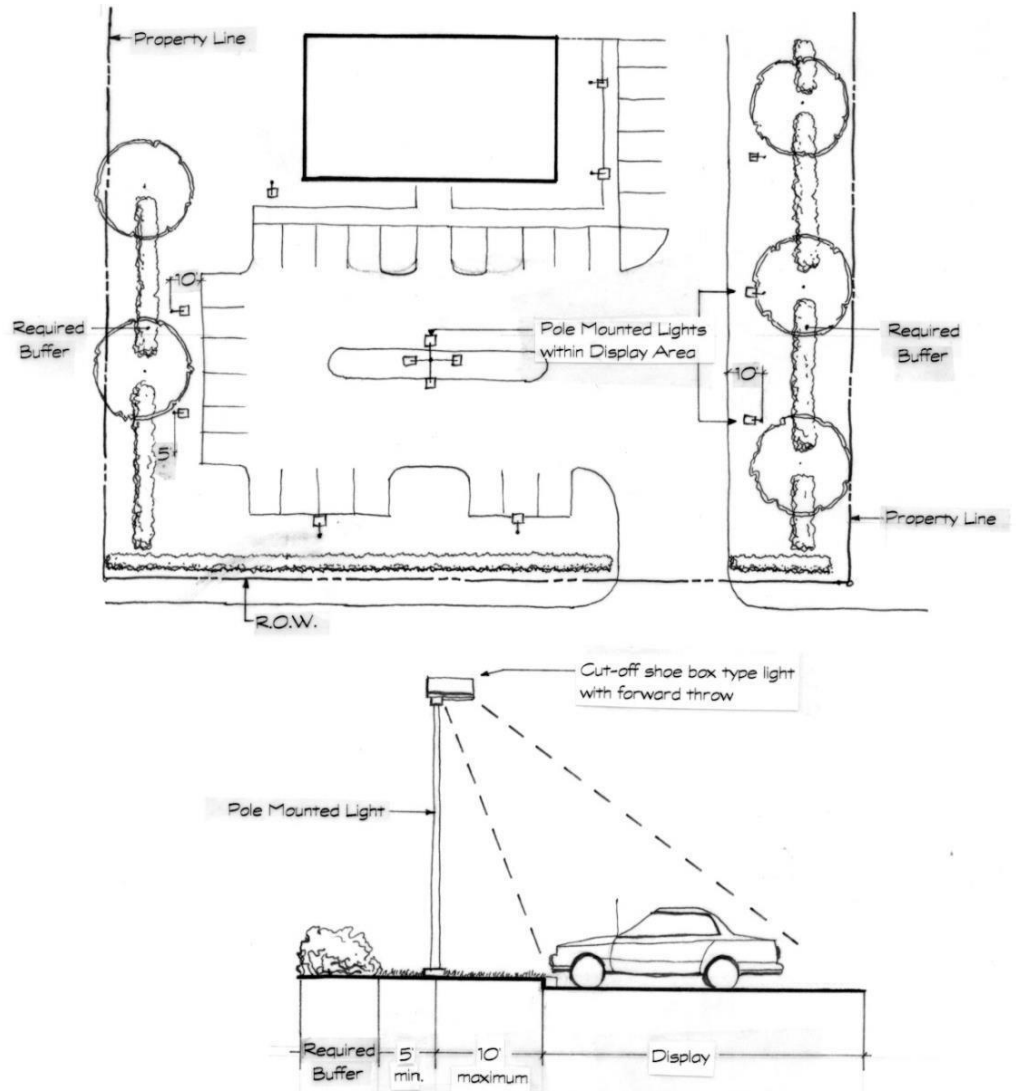

Figure 8.6.4.B Location/Lighting for Outdoor Display

C) Architectural/Site Compatibility

Lighting fixtures shall be of a design and size compatible with the principal building of a development and adjacent areas, and shall be designed to be an integral part of the entire development site. Light fixtures and poles will be considered neutral elements of the site and must be finished in black, dark brown, or architectural bronze. All light fixtures/poles on site including building mounted lighting shall be the same color throughout the development. Bright colors or white are prohibited.

D) *Spillover Light and Glare Control*

- 1) All outdoor lighting shall be designed and located such that the maximum illumination measured in initial foot-candles at the property line shall not exceed 0.3 onto adjacent residential sites and 1.0 onto adjacent non-residential sites and public rights-of-way.
- 2) ~~Non cutoff lights are prohibited along the perimeter of non residential sites where they are immediately adjacent to adjoining residential~~

properties. Non-cutoff lights may require external caps and/or internal shields to control glare.

- ~~3) Cutoff lights shall be full cutoff with no sag-type lenses;~~
- ~~4) Cutoff lights used along the perimeter of non-residential sites where they are immediately adjacent to adjoining residential properties must be fitted with externally mounted shields placed on the residential side. The shields must be appropriately sized to sufficiently limit visible glare from the light onto the residential properties. Additional internal shields or other devices may be required to direct the light away from residential properties.~~

2) **All fixtures shall be fully shielded, full cutoff type fixtures with a concealed lamp/light source, except as otherwise stated within this Section.**

3) ***Backlight, Uplight, and Glare (BUG)***
The three components of BUG ratings are based on IES TM-15-07 "Luminaire Classification System for Outdoor Luminaires" from the Illuminating Engineering Society, as amended (see Figure 8.6.4.D). The rating system is assigned a value between 0 and 5 for each component with lower numbers indicating less light in a given direction.

a) **Backlight (B) creates light trespass onto adjacent sites. The B rating accounts for the amount of light 0 to 90 degrees vertical from the ground in the direction opposite from the area intended to be lit. Except as otherwise stated in this Section, the maximum permitted backlight (B) rating shall be:**

(i) **3 for fixtures located 20 feet or less from a public right-of-way.**

(ii) **2 for fixtures located 20 feet or less from the property line of a residential use or a vacant property in a residential zoning district.**

b) **Uplight (U) contributes to artificial sky glow. The U rating defines the amount of light into the upper hemisphere 90 to 180 degrees vertical from the ground. Except as otherwise stated in this Section, the maximum permitted uplight (U) rating is 0, since all fixtures should be full cutoff.**

c) **Glare (G) is the component of light that can be annoying or visually disabling. The G rating accounts for the amount of front light and backlight 60 to 90 degrees vertical from the ground. Except as otherwise stated in this Section, the maximum permitted glare (G) rating shall be:**

(i) 1 for fixtures located 20 feet or less from a public right-of-way.

(ii) 0 for fixtures located 20 feet or less from the property line of a residential use or a vacant property in a residential zoning district.

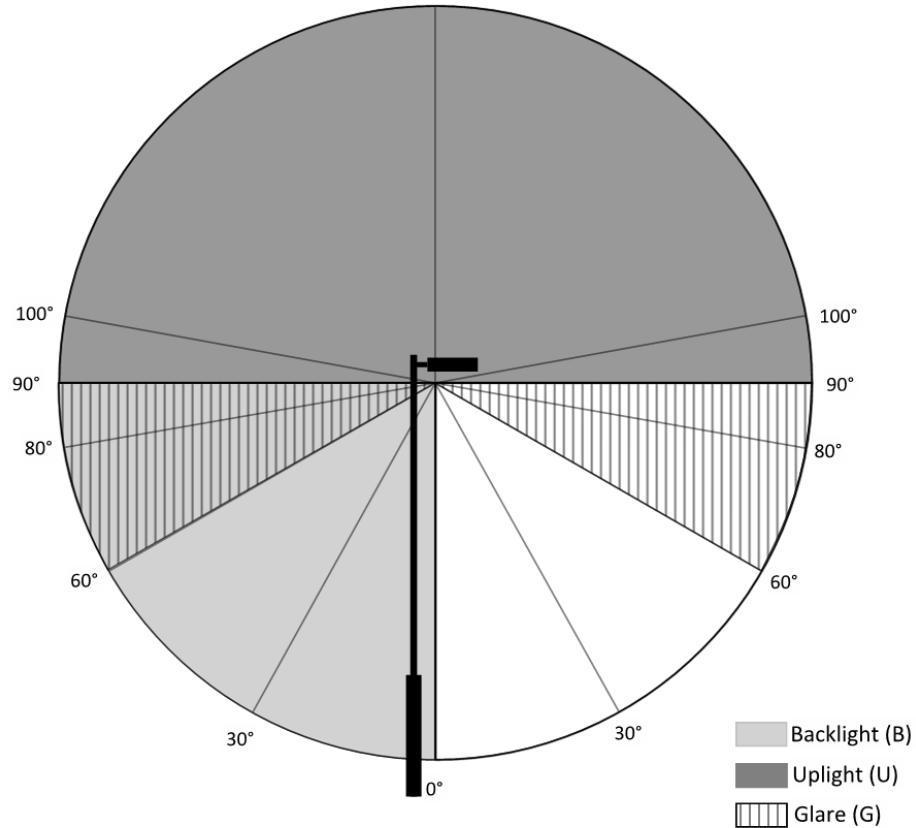

Figure 8.6.4.D BUG Rating Zones

E) ~~Wattage~~**Lumens**
~~Lamps for non cutoff fixtures shall not exceed 100 watts. Lamps for full cut-off fixtures shall not exceed 250 watts.~~ **15,500 lumens.**

F) *Building, Ground Mounted Fixtures and Accent Lighting*
Lighting shall not be mounted to buildings or used to illuminate buildings or other site features unless approved as integral elements on the development plan. Lighting will not be approved unless the light fixtures are carefully selected, located, aimed, and shielded so that light is directed only onto limited parts of the building façade, specimen landscape, and site features, and spillover light is minimized (see also Secs. 8.6.4.C *Architectural/Site Compatibility*, 8.6.4.D *Spillover Light and Glare Control*, and 8.6.4.E ~~Wattage~~**Lumens**. Building, ground mounted fixtures and accent lighting must meet the following criteria:

- 1) Lights must not be used to illuminate entire portions of building(s), landscape, or site features.

- 2) Building mounted lights such as wall-pack and goose-neck type fixtures shall be fully shielded, ~~true full~~ cutoff type fixtures (concealed lamp/light source). The lighting must be directed downward, and the ~~wattage~~ **lumens** must not exceed ~~75 watts~~ **2,500 lumens**.
- 3) Accent lights must be low-~~wattage~~ **lumen** or low-voltage and the maximum illumination on any surface shall not exceed 5.0 average initial foot-candles.
- 4) Awnings and canopies used for building accents over doors, windows, ~~and~~ etc. shall not be internally lit (i.e., from underneath or behind). If lit from above, the lighting must be spaced sparingly so that only limited portions of awnings and canopies are accented.
- 5) Lights that flash, move, revolve, rotate, scintillate, blink, flicker, vary in intensity or color, or use intermittent electrical pulsation are prohibited. Continuous lighting such as, but not limited to tubes or strings of lights on rooflines and building edges are prohibited (see also Sec. 8.7.2.1 Prohibited Signs).

G) *Floodlights*

Floodlights or similar types of directional lighting attached to light poles or buildings to illuminate large portions of the site and/or building(s) are prohibited unless the Planning Director gives special permission and approval is given through the development review process. The use of floodlights or similar types of directional lighting will only be considered for special approval for Industrial type uses or where it can be demonstrated that extreme site or design constraints warrant their use.

H) Lighting for Gas Station/Convenience Store Canopies

Lighting for canopies for service stations and similar uses shall be restricted to no more than two ~~(2) 320-watt~~ **11,000 lumen** recessed lighting fixtures (including lenses) mounted flush with the bottom of the canopy on each side of a gasoline pump island, or any other design that meets the standards of this ~~o~~**O**rdinance. Lighting for canopies for service stations and other similar uses such as but not limited to bank and pharmacy drive through, and large covered main entrance canopies shall not exceed an initial maximum level of 12 foot-candles as measured at ground level at the inside of the outside edge of the canopy and an initial average level of 25 foot-candles under the canopy.

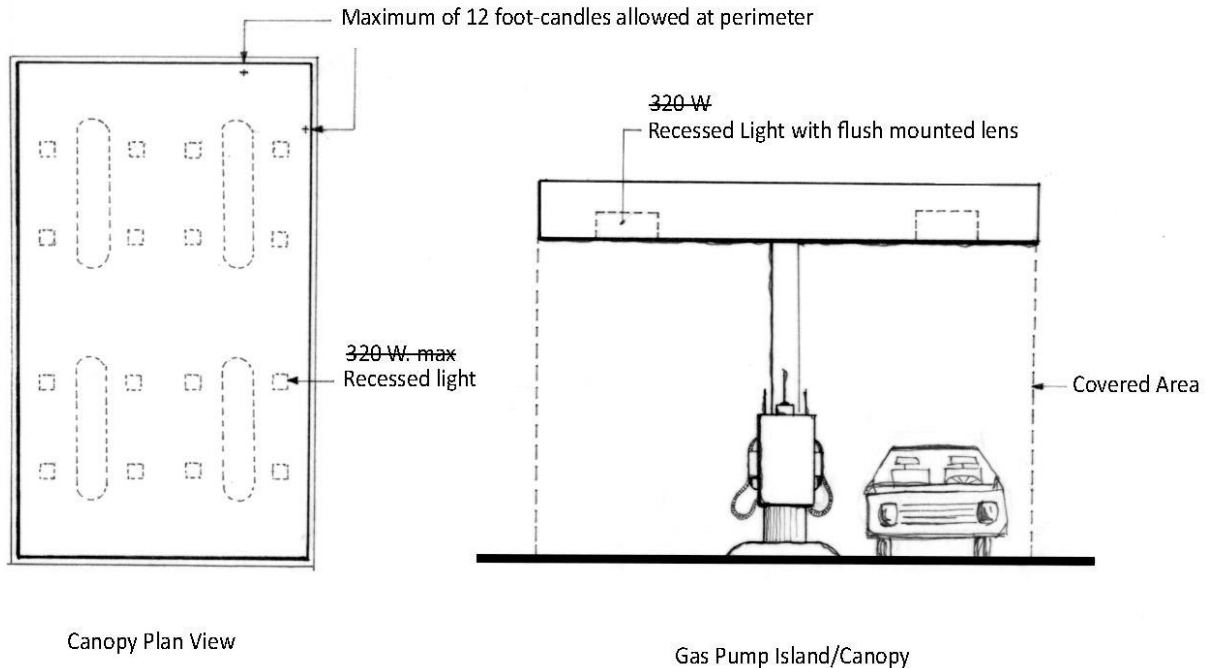

8.6.4.H Exterior Lighting Design Requirements – Lighting for Gas Stations & Convenience Store Canopies

- I) **Sports and Athletic Field Lighting**
 Lighting for ball fields and sports courts may need to exceed illumination standards for general recreational needs in order to meet higher standards required for tournament play. The Planning Director must approve any deviations from the illumination standards; however, before any changes will be considered the sports lighting must meet these minimum standards:
- 1) Fixtures ~~must~~ **shall** not exceed 80 feet in mounting height (this includes bases and/or other mounting structures).
 - 2) Fixtures ~~must~~ **shall** be fitted with the manufacturer's glare control package. If the manufacturer does not have a glare control package, the fixture specification must be changed to a manufacturer that offers a glare control package.
 - 3) Fixtures ~~must~~ **shall** be designed and aimed so that their beams fall within the primary playing area and the immediate surroundings, so that off-site direct illumination is significantly restricted. Spillover levels at the property line must not exceed 0.3 foot-candles onto residential properties.
 - 4) Lighting shall be extinguished no later than one (1) hour after the event ends.
- J) **Private Recreation Facility Lighting**
 Lighting for ball fields and sports courts at a private recreation facility may exceed illumination standards set forth in this Section in order to meet higher standards required for active recreation. The Planning Director must approve any deviations

from the illumination standards; however, before any changes will be considered the proposed lighting ~~must~~ shall meet these minimum standards:

- 1) Fixtures ~~must~~ shall not exceed 35 feet in mounting height (this includes bases and/or other mounting structures).
 - 2) Fixtures ~~must~~ shall be fitted with the manufacturer's glare control package. If the manufacturer does not have a glare control package, the fixture specification ~~must~~ shall be changed to a manufacturer that offers a glare control package.
 - 3) Fixtures ~~must~~ shall be designed and aimed so that their beams fall within the primary playing area and the immediate surroundings, so that off-site direct illumination is significantly restricted. Spillover levels at the property line ~~must~~ shall not exceed 0.3 foot-candles onto residential properties.
 - 4) Lighting shall be extinguished no later than 10:00 pm.
 - 5) A 10-foot Type A buffer shall be required along any property line of the private recreation facility when such lighting fixture is within 100 feet of a residential use.
 - 6) Such lighting shall be proposed at the time of Master Subdivision Plan or Site Plan approval for new private recreation facilities. Approval of a Special Use Permit and a revised Site Plan Lighting Sheet and Landscape Sheet are required for any proposal to exceed illumination standards of this Section at an existing private recreation facility.
- K) Illuminated Tubing or Strings of Light
Illuminated tubing or strings of light on trees and landscaping or outlining property lines or open sales areas, rooflines or wall edges of buildings are prohibited except as provided in Sec. 8.7.1.A.25 *Holiday*. This prohibition does not apply to Town of Apex owned trees provided that the illuminated tubing or strings of lights on trees are not permanently installed and are removed from the tree and reinstalled or replaced at least twice per year.
- L) Illumination for a Regional Recreation Complex
- 1) Unless specifically exempted or amended below, all exterior lighting must meet the standards found in Sec. 8.6 *Exterior Lighting*. Structures erected to support and function as operational elements of outdoor amusements such as, but not limited to, bungee jumping, ropes courses, and zip-lines may be illuminated.
 - 2) Lights shall not be used to illuminate entire portions of building(s), landscape, or site features.
 - 3) Building-mounted lights such as wall-pack and goose-neck type fixtures shall be fully shielded, ~~true~~ full cutoff type fixtures (concealed lamp/light

source). The lighting must be directed downward, and ~~the wattage~~ **lumens must shall** not exceed ~~100 watts~~ **2,500 lumens**.

- 4) Awnings and canopies used for building accents over doors and windows shall not be internally lit (e.g. from underneath or behind). If lit from above, the lighting must be spaced sparingly so that only limited portions of awnings and canopies are accented.
- 5) Critical areas associated with an outdoor amusement activity, such as, but not limited to, entrances and exits, approaches and mounting areas, queue and waiting areas, ticket booths or similar service facilities, and observation areas must be reasonably sized for the purpose they serve and identified and laid out on plans in close proximity to the outdoor amusement activities that they serve. Illumination standards for these areas shall not exceed a horizontal illuminance average of 5.0 foot-candles and a uniformity ratio of 4/1 (average/minimum) and height of 35 feet.
- 6) Except as allowed under Sec. 8.6.4.F *Building, Ground Mounted Fixtures and Accent Lighting*, all up-lighting, spot lights, and floodlights are prohibited.
- 7) Lights that flash, move, revolve, rotate, scintillate, blink, flicker, vary in intensity or color, or use intermittent electrical pulsation are prohibited. Continuous lighting such as, but not limited to, tubes or strings of lights on rooflines, building edges, and outdoor amusement activities are allowed (see also Sec. 8.7.2.1 *Prohibited Signs*).

M) Controls shall be provided that automatically extinguish all outdoor lighting when sufficient daylight is available using a control device or system such as a photoelectric switch, astronomic time switch or equivalent functions from a programmable lighting controller, building automation system, or lighting energy management system, all with battery or similar backup power or device.

N) For non-residential uses, the lumens for each fixture shall be reduced by at least 30% no later than one (1) hour after the business is closed to the public except that lighting reductions are not required for the following:

- 1) **When a site contains no more than two (2) fixtures.**
- 2) **Code required lighting for steps, stairs, walkways, and building entrances.**
- 3) **Motion activated lighting.**
- 4) **Lighting approved by a Special Use Permit in which times of operation are specifically identified.**
- 5) **Businesses that operate on a 24-hour basis.**

- 6) **When in the opinion of the Technical Review Committee, lighting levels must be maintained to ensure the health, safety, and welfare of the community.**

8.6.5 Exemptions

The standards of this ~~s~~Section shall not apply to:

- A) Individual residential lighting that is not reviewed as part of a development plan, except for a Single-Family Recreational Use as defined in Sec. 4.5.4.
- B) Lighting associated with temporary uses that have been permitted, provided that the lighting meets the general standards of this ~~s~~Section.
- C) Seasonal lighting that is part of customary holiday decorations and annual civic events, provided that it meets all the requirements of Sec. 8.7.1.A.25 *Holiday*.
- D) Lighting associated with sign illumination as set forth in Sec. 8.7.6.B *Sign Illumination*.
- E) ~~Municipal~~**Street** lighting installed within public rights-of-way or on Town-owned property for the benefit of public health, safety, and welfare.

8.6.6 Final Inspection

Before certificates of occupancy are released, the owner/builder must supply the Town with a final letter of certification from the lighting engineer, qualified lighting professional (Sec. 8.6.2.C), or lighting manufacturer verifying that all site lighting is installed according to Town standards, the approved plans, and any applicable conditions. The certification must include a report indicating that all site and exterior mounted building lighting was inspected and the light levels measured and recorded (including spillover lighting). Any irregularities or deviations from the approved site plan, Town standards, or applicable conditions must be pointed out in the report.

8.6.7 Lighting Definitions

Astronomic Time Switch: An automatic lighting control device that switches outdoor lighting relative to time of solar day with time of year correction.

Backlight: For an exterior fixture, lumens emitted in the quarter sphere below horizontal and in the opposite direction of the intended orientation of the fixture. For fixtures with symmetric distribution, backlight will be the same as front light.

BUG: A fixture classification system that classifies backlight (B), uplight (U) and glare (G).

Foot-candle: The unit of measure expressing the quantity of light received on a surface. One (1) foot-candle is the illuminance produced by a candle on one (1) square foot of surface area measured from a distance of one (1) foot.

Glare: Light entering the eye directly from fixtures or indirectly from reflective surfaces that causes visual discomfort or reduced visibility.

Lamp: A generic term for a source of optical radiation (i.e. "light"), often called a "bulb" or "tube". Examples include incandescent, fluorescent, high-intensity discharge (HID) lamps, and low-pressure sodium (LPS) lamps, as well as light-emitting diode (LED) modules and arrays.

Landscape Lighting: Lighting of trees, shrubs, or other plant material as well as ponds and other landscape features.

LED: Light Emitting Diode.

Light Pollution: Any adverse effect of artificial light including, but not limited to, glare, light trespass, sky glow, energy waste, compromised safety and security, and impacts on the nocturnal environment.

Light Trespass: Light that falls beyond the property it is intended to illuminate.

Lighting: "Electric" or "man-made" or "artificial" lighting. See "lighting equipment".

Lighting Equipment: Equipment specifically intended to provide gas or electric illumination, including but not limited to, lamp(s), luminaire(s), ballast(s), poles, posts, lens(es), and related structures, electrical wiring, and other necessary or auxiliary components.

Photoelectric Switch: A control device employing a photocell or photodiode to detect daylight and automatically switch lights off when sufficient daylight is available.

Sales area: Uncovered area used for sales of retail goods and materials, including but not limited to automobiles, boats, tractors and other farm equipment, building supplies, and gardening and nursery products.

Sky Glow: The brightening of the nighttime sky that results from the scattering and reflection of artificial light by moisture and dust particles in the atmosphere. Sky glow is caused by light directed or reflected upwards or sideways and reduces one's ability to view the night sky.

Time Switch: An automatic lighting control device that switches lights according to time of day.

Uplight: For an exterior luminaire, flux radiated in the hemisphere at or above the horizontal plane.

Section 2. These amendments shall not apply to projects for which an application for development approval has been submitted before the effective date of this ordinance.

Section 4. The Planning Director and/or Town Manager are hereby authorized to renumber, revise formatting, correct typographic errors, to verify and correct cross references, indexes and diagrams as necessary to codify, publish, and/or accomplish the provisions of this ordinance or future amendments as long as doing so does not alter the terms of this ordinance.

Section 5. All ordinances or parts of ordinances in conflict with this ordinance are hereby repealed. If any section, paragraph, subdivision, clause or provision of this ordinance shall be adjudged invalid, such adjudication shall apply only to such section, paragraph, subdivision, clause or provision so adjudged and the remainder of the ordinance shall be deemed valid and effective.

Section 6. The ordinance shall be effective on the 1st day of January 2024.

Introduced by Council Member _____

Seconded by Council Member _____

Attest:

TOWN OF APEX

Allen Coleman, CMC, NCCCC
Town Clerk

Jacques K. Gilbert
Mayor

Approved As To Form:

Laurie L. Hohe
Town Attorney