



## City of Angels Request for Bid (RFB)

**Project Title:** Chip Sealing, Speed Table Installation, and Pavement Marking

**Project Number:** 24-001

**Issue Date:**

**Bid Due Date:** 11/8/2024 by 3:00 PM

### I. Introduction

The City of Angels is soliciting sealed bids from qualified contractors for chip sealing, speed table installation, and pavement marking services for designated roadways within the city. This project is designed to improve the surface conditions, control speeding, and enhance the visibility of lanes on key transportation routes.

### II. Scope of Work

The work will involve the following:

1. **Chip Sealing:**
  - Prepare and clean road surfaces.
  - Apply a chip seal coat to the designated roadways.
  - Ensure smooth surface treatment with adequate materials according to Caltrans Standard Specifications.
2. **Speed Table Installation:**
  - Install speed tables at designated locations along the roads.
  - Ensure compliance with city specifications for height, length, and material of speed tables. Details are included in Appendix A.
3. **Lane Striping:**

- Remove any existing pavement markings (if necessary).
- Stripe crosswalks, stop bars, arrows, and lane markings as directed.

### III. Project Specifications

1. **Location:**

The project covers specific arterial roadways within the City of Angels. Detailed maps of the work areas are included in Appendix A.

2. **Materials:**

- Chip shall be placed consistent with section 37-2 of the Caltrans Standard Specifications.
- Pavement Markings shall be consistent with section 84-2.02F Two-Component Paint as described in the Caltrans Specifications.
- Asphalt materials for speed table installation shall be placed consistent with section 39 of the Caltrans Standard Specifications.

3. **Safety and Traffic Control:**

- Contractor is responsible for all necessary traffic control measures during the duration of the project.
- Adequate signage, cones, and personnel should be in place to ensure public and worker safety.

4. **Project Schedule:**

- Project must be completed within 30 days from the issuance of the Notice to Proceed.
- A project timeline, including proposed milestones and completion dates, must be submitted with the bid.

### IV. Bid Submission Requirements

1. **Qualifications:**

- Contractors must have a minimum of 10 years of experience in road construction and maintenance projects of similar scope.
- Provide a list of previous projects completed within the past 5 years, including client references and contact information.



2. **Bid Pricing:**

- Submit a detailed cost breakdown for all phases of the project, including quantities included, materials, labor, equipment, and any other associated costs.
- Bids must be submitted in a sealed envelope labeled “City of Angels Chip Sealing, Speed Table, and Pavement Marking Project Bid.”

3. **Bonding and Insurance:**

- Contractors must submit proof of bonding and insurance as required by the City of Angels.
- A performance bond equal to 100% of the contract price will be required from the successful bidder.

4. **Submission Deadline:**

- All bids must be received by 3:00 PM on 11/8/2024 at the following location:  
**City of Angels Finance Department**  
200 Monte Verda St. Ste B  
Attn: Chris O’Flinn Public Works Superintendent  
Late submissions will not be accepted.

## V. Pre-Bid Meeting

A pre-bid meeting will be held on 11/1/2024 at 9:00 AM in front of 600 Gardner Ln. Attendance is mandatory for all potential bidders.

## VI. Evaluation Criteria

Bids will be evaluated based on the following criteria:

1. Cost and overall value to the City.
2. Experience and qualifications of the contractor.
3. Proposed project schedule.
4. Compliance with the bid submission requirements.
5. References and past performance on similar projects.



## VII. Contact Information

For questions or further information, please contact:

**Chris O'Flinn**

City of Angels Public Works Department

Phone: 209-840-3063

Email: [chrisoflinn@angelscamp.gov](mailto:chrisoflinn@angelscamp.gov)

The City of Angels reserves the right to reject any and all bids, waive any irregularities, and to award the contract in the best interest of the City. All bids must comply with federal, state, and local laws, rules, and regulations.

**End of Request for Bid**



## Appendix A



**ASPHALT CONCRETE SPEED CUSHION DETAILS**

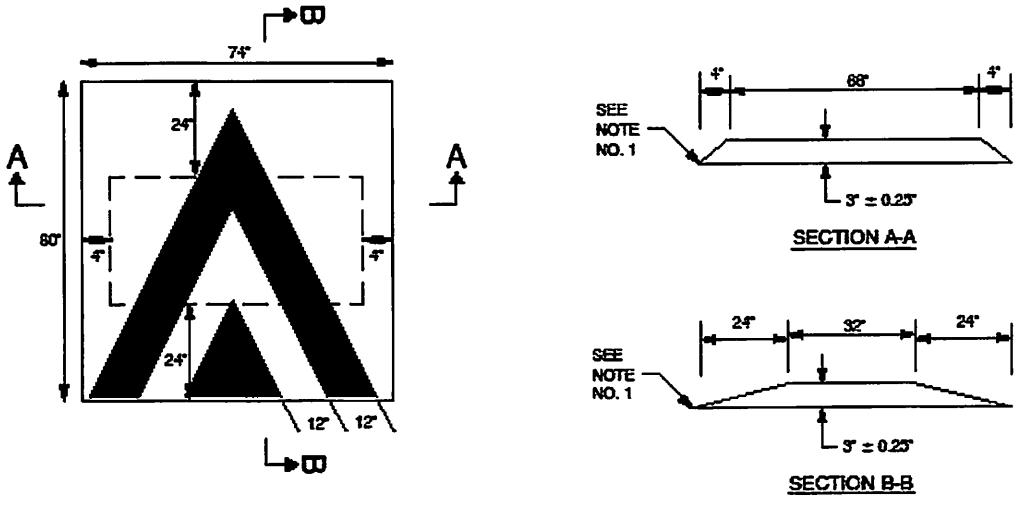

**TYPICAL 30' ROAD LAYOUT - CURB TO CURB**

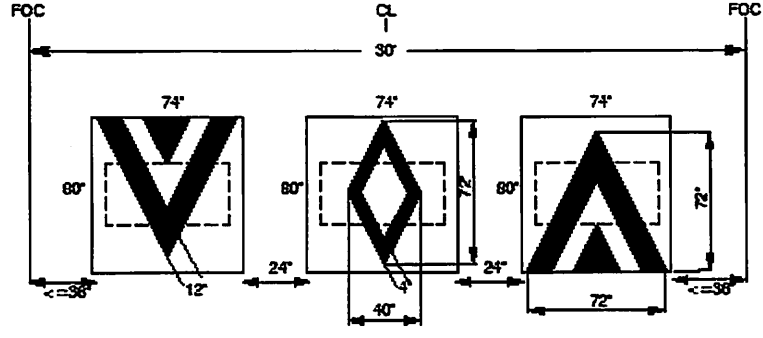

- NOTES:**
1. MAXIMUM STEP OF TRANSITION FROM PAVEMENT TO RAMP IS 0.3".
  2. NUMBER OF SPEED CUSHION MODULES VARY BETWEEN 2 AND 3 BASED ON STREET WIDTH.
  3. WIDTH BETWEEN SPEED CUSHION MODULES VARY BASED ON STREET WIDTH.
  4. DISTANCE BETWEEN FACE OF CURB (FOC), GUTTER WIDTH AND LAST MODULE EDGE SHOULD NOT EXCEED 4"

N.T.S

**SPEED CUSHION**  
 FIGURE A-96

Oct 06, 2021  
 P:\04 - Traffic Calming\Speed Hump Policy - 2017\_end beyond\Speed Hump Standards\FigA-96-speed\_cushion.dwg



**ASPHALT CONCRETE SPEED CUSHION DETAILS**

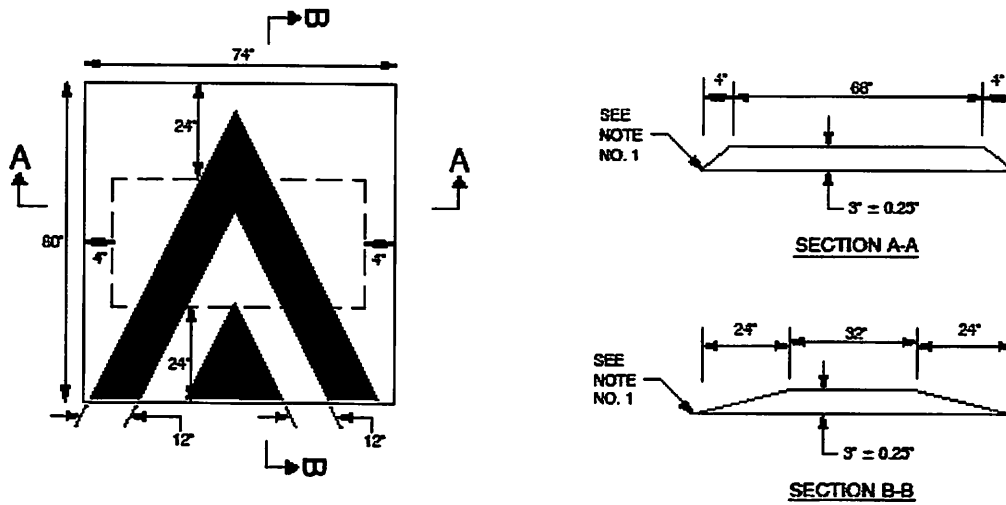

**TYPICAL 20' ROAD LAYOUT - CURB TO CURB**

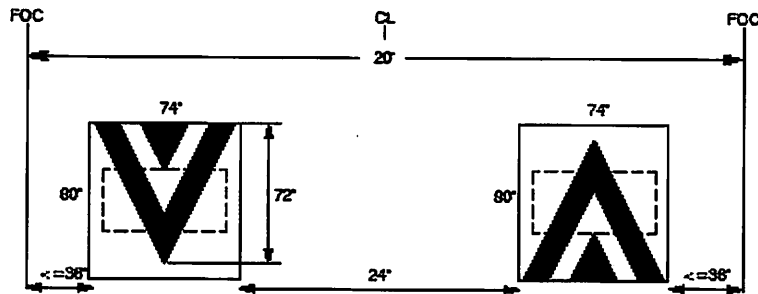

**NOTES:**

1. MAXIMUM STEP OF TRANSITION FROM PAVEMENT TO RAMP IS 0.5".
2. NUMBER OF SPEED CUSHION MODULES VARY BETWEEN 2 AND 3 BASED ON STREET WIDTH.
3. WIDTH BETWEEN SPEED CUSHION MODULES VARY BASED ON STREET WIDTH.
4. DISTANCE BETWEEN FACE OF CURB (FOC), GUTTER WIDTH AND LAST MODULE EDGE SHOULD NOT EXCEED 4'

N.T.S

**SPEED CUSHION**

FIGURE A-90

Oct 12, 2021  
 P:\04 - Traffic Calming\Speed Hump Policy - 2017...and beyond\Speed Hump Standards\14-042\_speed\_cushion.dwg



Home of the Jumping Frog • Angelscamp.gov

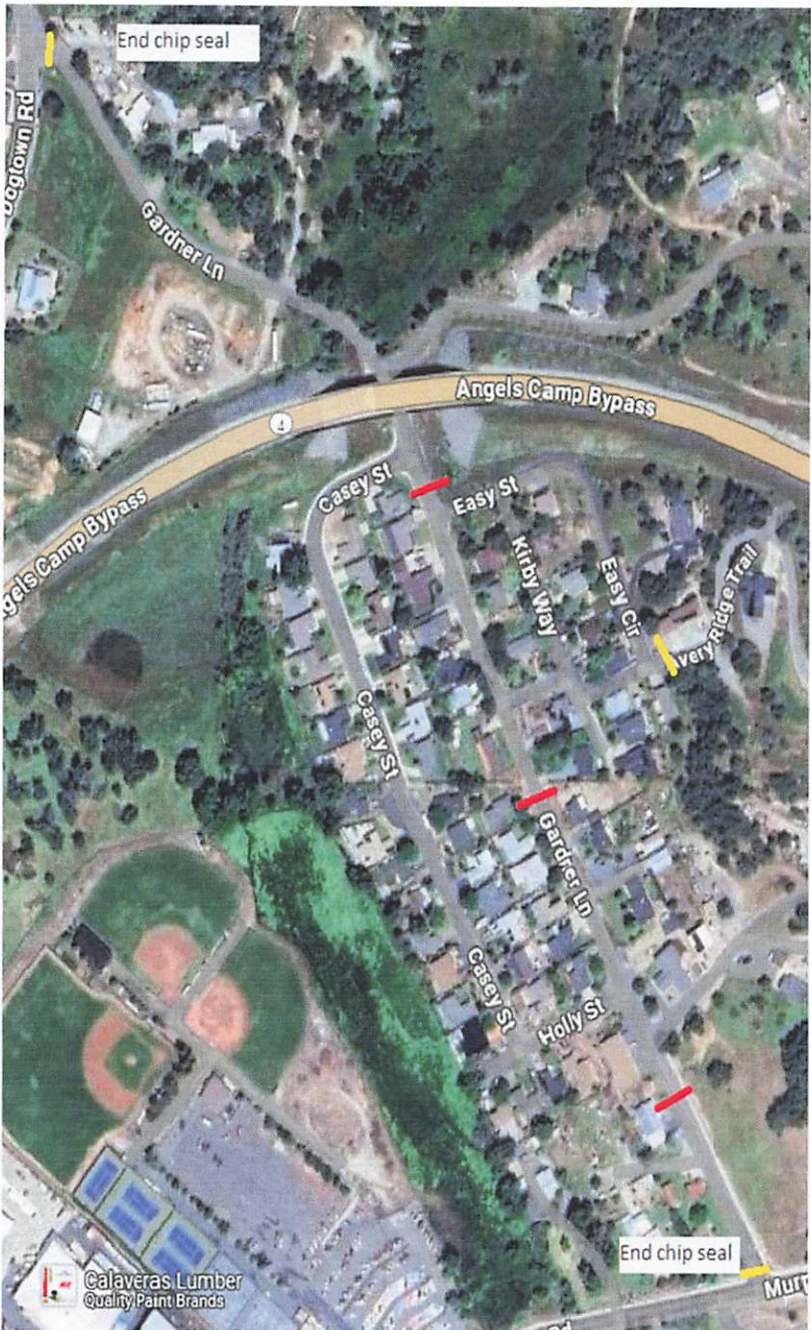

Average road width 21 ft.

— End Chip Sealing

— Speed Tables

Road list:

- 1. Gardner Ln.
- 2. Casey St.
- 3. Easy St
- 4. Easy Circle
- 5. Kirby Way
- 6. Holly St.

