



March 30, 2023

Mr. Otis Spriggs
Director of Development Services
City of Angleton
121 S. Velasco
Angleton, TX 77515

Re: On-Going Services
Windrose Green Section 3 Subdivision Final Plat – 1st Submittal Review
Angleton, Texas
HDR Job No. 10361761

Dear Mr. Spriggs:

HDR Engineering, Inc. (HDR) has reviewed the final plat for the above referenced subdivision and offers the following comments:

Sheet 1 of 3

1. Remove additional text shown in the Engineer's Certification Block
2. Provide the required plat notes take from the Angleton LDC Sec.23-115, L.
3. Update text shown. Plat drawing shows "O.P.R.B.C."

Sheet 2 of 3

4. Label existing New Dawn Drive from Windrose Green Section 1.
5. Verify street name "Windrose Bend". Per preliminary plat, "Windrose Bend Drive" was used.
6. Update the FEMA FIRM information in Plat Note #8 to reflect current information
7. Show bearing and distance for the east line shown along the King Subdivision.

HDR takes no objection to the proposed Windrose Green Section 3 Subdivision Final Plat with the exceptions noted. Please note, this does not necessarily mean that the entire drawings, including all supporting data and calculations, has been completely checked and verified; however, the drawings and supporting data are signed, dated, and sealed by a Registered Professional Land Surveyor licensed to practice in the State of Texas, which therefore conveys the surveyor's responsibility and accountability.

If you have any questions, please feel free to contact us at our office (713)-622-9264.

Sincerely,

HDR Engineering, Inc.

Javier Vasquez, P.E., CFM
Civil Engineer

cc: Files (10361761/10336228)

Attachments

STATE OF TEXAS §
COUNTY OF BRAZORIA §

NOW, THEREFORE, KNOW ALL MEN BY THESE PRESENTS, THAT EMPTOR ANGLETON, LLC ACTING HEREIN BY AND THROUGH ITS DULY AUTHORIZED OFFICERS, DOES HEREBY ADOPT THIS PLAT DESIGNATING THE HEREINAbove DESCRIBED PROPERTY AS WINDROSE GREEN SECTION THREE, A SUBDIVISION IN THE JURISDICTION OF THE CITY OF ANGLETON, TEXAS, AND DOES HEREBY DEDICATE, IN FEE SIMPLE, TO THE PUBLIC USE FOREVER, THE STREETS, ALLEYS AND PUBLIC PARKLAND SHOWN THEREON. THE STREETS, ALLEYS AND PARKLAND ARE DEDICATED FOR STREET PURPOSES, THE EASEMENTS AND PUBLIC USE AREAS, AS SHOWN, ARE DEDICATED FOR THE PUBLIC USE FOREVER, FOR THE PURPOSES INDICATED ON THE PLAT. NO BUILDINGS, FENCES, TREES, SHRUBS, OR OTHER IMPROVEMENTS OR GROWTHS SHALL BE CONSTRUCTED OR PLACED UPON, OVER, OR ACROSS THE EASEMENTS AS SHOWN, EXCEPT THAT LANDSCAPE IMPROVEMENTS MAY BE PLACED IN LANDSCAPE EASEMENTS, IF APPROVED BY THE CITY OF ANGLETON. IN ADDITION, UTILITY EASEMENTS MAY ALSO BE USED FOR THE MUTUAL USE AND ACCOMMODATION OF ALL PUBLIC UTILITIES DESIRING TO USE OR USING THE SAME UNLESS THE EASEMENT LIMITS THE USE TO PARTICULAR UTILITIES, SAID USE BY PUBLIC UTILITIES BEING SUBORDINATE TO THE PUBLIC'S AND CITY OF ANGLETON'S USE THEREOF. THE CITY OF ANGLETON AND PUBLIC UTILITY ENTITIES SHALL HAVE THE RIGHT TO REMOVE AND KEEP REMOVED ALL OR PARTS OF ANY BUILDINGS, FENCES, TREES, SHRUBS, OR OTHER IMPROVEMENTS OR GROWTHS WHICH MAY IN ANY WAY ENDANGER OR INTERFERE WITH THE CONSTRUCTION, MAINTENANCE, OR EFFICIENCY OF THEIR RESPECTIVE SYSTEMS IN SAID EASEMENTS. THE CITY OF ANGLETON AND PUBLIC UTILITY ENTITIES SHALL AT ALL TIMES HAVE THE FULL RIGHT OF INGRESS AND EGRESS TO OR FROM THEIR RESPECTIVE EASEMENTS FOR THE PURPOSE OF CONSTRUCTING, RECONSTRUCTING, INSPECTING, PATROLLING, MAINTAINING, READING METERS, AND ADDING TO OR REMOVING ALL OR PARTS OF THEIR RESPECTIVE SYSTEMS WITHOUT THE NECESSITY AT ANY TIME OF PROCURING PERMISSION FROM ANYONE.

STATE OF TEXAS §
COUNTY OF BRAZORIA §

THIS PLAT IS HEREBY ADOPTED BY THE OWNERS AND APPROVED BY THE CITY OF ANGLETON (CALLED "CITY") SUBJECT TO THE FOLLOWING CONDITIONS WHICH SHALL BE BINDING UPON THE OWNERS, THEIR HEIRS, GRANTEES AND SUCCESSORS: THE PORTION OF THE PLAT CALLED "DRAINAGE AND DETENTION EASEMENT", THE DRAINAGE AND DETENTION EASEMENT WITHIN THE LIMITS OF THIS ADDITION, WILL REMAIN OPEN AT ALL TIMES AND WILL BE MAINTAINED IN A SAFE AND SANITARY CONDITION BY THE OWNERS OF THE LOT OR LOTS THAT ARE TRAVERSED BY OR ADJACENT TO THE DRAINAGE AND DETENTION EASEMENT. THE CITY WILL NOT BE RESPONSIBLE FOR THE MAINTENANCE AND OPERATION OF SAID EASEMENT OR FOR ANY DAMAGE TO PRIVATE PROPERTY OR PERSON THAT RESULTS FROM CONDITIONS IN THE EASEMENT, OR FOR THE CONTROL OF EROSION, NO OBSTRUCTION TO THE NATURAL FLOW OF STORMWATER RUN-OFF SHALL BE PERMITTED BY CONSTRUCTION OF ANY TYPE OF BUILDING, FENCE, OR ANY OTHER STRUCTURE WITHIN THE DRAINAGE AND DETENTION EASEMENT AS HEREINAbove DEFINED, UNLESS APPROVED BY THE CITY ENGINEER. PROVIDED, HOWEVER, IT IS UNDERSTOOD THAT IN THE EVENT IT BECOMES NECESSARY FOR THE CITY TO ERRECT OR CONSIDER ERRECTING ANY TYPE OF DRAINAGE STRUCTURE IN ORDER TO IMPROVE THE STORM DRAINAGE THAT MAY BE OCCASIONED BY THE CITY SHALL HAVE THE RIGHT TO ENTER UPON THE DRAINAGE AND DETENTION EASEMENT AT ANY POINT, OR POINTS, TO INVESTIGATE, SURVEY OR TO ERRECT, CONSTRUCT AND MAINTAIN ANY DRAINAGE FACILITY DEEMED NECESSARY FOR DRAINAGE PURPOSES. EACH PROPERTY OWNER SHALL KEEP THE DRAINAGE AND DETENTION EASEMENT CLEAN AND FREE OF DEBRIS, SILT, AND ANY SUBSTANCE WHICH WOULD RESULT IN UNSANITARY CONDITIONS OR OBSTRUCT THE FLOW OF WATER, AND THE CITY SHALL HAVE THE RIGHT OF INGRESS AND EGRESS FOR THE PURPOSE OF INSPECTION AND SUPERVISION OF MAINTENANCE WORK BY THE PROPERTY OWNER TO ALLEVIATE ANY UNDESIRABLE CONDITIONS WHICH MAY OCCUR. THE NATURAL DRAINAGE THROUGH THE DRAINAGE AND DETENTION EASEMENT IS SUBJECT TO STORM WATER OVERFLOW AND NATURAL BANK EROSION TO AN EXTENT WHICH CANNOT BE DEFINITELY DEFINED. THE CITY SHALL NOT BE HELD LIABLE FOR ANY DAMAGES OF ANY NATURE RESULTING FROM THE OCCURRENCE OF THESE NATURAL PHENOMENA, OR RESULTING FROM THE FAILURE OF ANY STRUCTURE, OR STRUCTURES, WITHIN THE EASEMENT.

STATE OF TEXAS §
COUNTY OF BRAZORIA §

THE OWNER OF LAND SHOWN ON THIS PLAT, IN PERSON OR THROUGH A DULY AUTHORIZED AGENT, DEDICATES TO THE USE OF THE PUBLIC FOREVER ALL STREETS, ALLEYS, PARKS, WATER COURSES, DRAINS, EASEMENTS AND PUBLIC PLACES THEREON SHOWN FOR THE PURPOSE AND CONSIDERATION THEREIN EXPRESSED.

EMPTOR ANGLETON, LLC
A TEXAS LIMITED LIABILITY COMPANY

BY: CDL VENTURES, LLC, MANAGER
BY: CONCORSE COMPANIES, LLC, MANAGER

JORDAN MACK, MANAGER

STATE OF TEXAS §
COUNTY OF BRAZORIA §

BEFORE ME, THE UNDERSIGNED, PERSONALLY APPEARED JORDAN MACK, MANAGER KNOWN TO ME TO BE THE PERSON WHOSE NAME IS SUBSCRIBED TO THE FOREGOING INSTRUMENT AND ACKNOWLEDGED TO ME THAT HE EXECUTED THE SAME FOR THE PURPOSES AND CONSIDERATIONS THEREIN EXPRESSED AND, IN THE CAPACITY, THEREIN STATED, GIVEN UNDER MY HAND AND SEAL OF OFFICE THIS ___ DAY OF ___, 2023.

NOTARY PUBLIC
STATE OF TEXAS

PRINT NAME

MY COMMISSION EXPIRES: _____

ANGLETON DRAINAGE DISTRICT

ANGLETON DRAINAGE DISTRICT ACCEPTED THIS THE ___ DAY OF ___, 20___, THE BOARD OF SUPERVISORS OF THE ANGLETON DRAINAGE DISTRICT DOES NOT WARRANT, REPRESENT, OR GUARANTEE:

- 1. THAT THE FACILITIES OUTSIDE THE BOUNDARIES OF THE SUBDIVISION PLAT ARE AVAILABLE TO RECEIVE RUNOFF FROM THE FACILITIES DESCRIBED IN THIS PLAT
- 2. THAT DRAINAGE FACILITIES DESCRIBED IN THIS PLAT ARE ADEQUATE FOR RAINFALL IN EXCESS OF ANGLETON DRAINAGE DISTRICT MINIMUM REQUIREMENTS.
- 3. THAT BUILDING ELEVATION REQUIREMENTS HAVE BEEN DETERMINED BY THE ANGLETON DRAINAGE DISTRICT.
- 4. THAT THE DISTRICT ASSUMES ANY RESPONSIBILITY FOR CONSTRUCTION, OPERATION OR MAINTENANCE OF SUBDIVISION DRAINAGE FACILITIES.

THE DISTRICT'S REVIEW IS BASED SOLELY ON THE DOCUMENTATION SUBMITTED FOR REVIEW, AND ON THE RELIANCE ON THE REPORT SUBMITTED BY THE TEXAS REGISTERED PROFESSIONAL ENGINEER.

THE DISTRICT'S REVIEW IS NOT INTENDED NOR WILL SERVE AS A SUBSTITUTION OF THE OVERALL RESPONSIBILITY AND/OR DECISION MAKING POWER OF THE PARTY SUBMITTING THE PLAT OR PLAN HEREIN, THEIR OR ITS PRINCIPALS OR AGENTS.

CHAIRMAN, BOARD OF SUPERVISORS

BOARD MEMBER

BOARD MEMBER

STATE OF TEXAS §
COUNTY OF BRAZORIA §

KNOW ALL MEN BY THESE PRESENTS:

THAT I, JOSEPH B. MAY, DO HEREBY CERTIFY THAT I PREPARED THIS PLAT FROM AN ACTUAL AND ACCURATE SURVEY OF THE LAND AND THAT THE CORNER MONUMENTS SHOWN THEREON WERE PROPERLY PLACED UNDER MY SUPERVISION.

JOSEPH B. MAY
REGISTERED PROFESSIONAL LAND SURVEYOR
TEXAS REGISTRATION NO. 5484

STATE OF TEXAS §
COUNTY OF BRAZORIA §

KNOW ALL MEN BY THESE PRESENTS:

THAT I, A. KHOSHAKHLAGH, DO HEREBY CERTIFY THAT PROPER ENGINEERING CONSIDERATION HAS BEEN PROVIDED IN THIS PLAT TO THE BEST OF MY KNOWLEDGE, THIS PLAT CONFORMS TO ALL REQUIREMENTS OF THE ANGLETON LLC, EXCEPT FOR ANY VARIANCES THAT WERE EXPRESSLY GRANTED BY THE CITY COUNCIL. ~~THIS PLAT FROM AN ACTUAL AND ACCURATE SURVEY OF THE LAND AND THAT THE CORNER MONUMENTS SHOWN THEREON WERE PROPERLY PLACED UNDER MY SUPERVISION.~~

A. KHOSHAKHLAGH, P.E.
TEXAS REGISTRATION NO. 101133

APPROVED THIS ___ DAY OF ___, 2023, BY THE PLANNING AND ZONING COMMISSION, CITY OF ANGLETON, TEXAS.

CHAIRMAN, PLANNING AND ZONING COMMISSION

CITY SECRETARY

APPROVED THIS ___ DAY OF ___, 2023, BY THE CITY COUNCIL, CITY OF ANGLETON, TEXAS.

MAYOR

CITY SECRETARY

STATE OF TEXAS §
COUNTY OF BRAZORIA §

THIS INSTRUMENT WAS ACKNOWLEDGED BEFORE ME ON THE ___ DAY OF ___, 2023, BY _____, CITY SECRETARY, CITY OF ANGLETON, ON BEHALF OF THE CITY.

Update text shown. Plat drawing shows O.P.R.B.C.

METES AND BOUNDS DESCRIPTION
23.70 ACRES

Being a 23.70-acre tract of land located in the T.S. Lee Survey, Abstract No. 318 in Brazoria County, Texas; said 23.70-acre tract being a portion of a called 154.6-acre tract of land recorded in the name of Emptor Angleton, LLC, in File No. 2020013621 of the Official Public Records of Brazoria County (O.P.R.B.C.); said 23.70-acre tract being more particularly described by metes and bounds as follows (all bearings are referenced to the Texas Coordinate System, North American Datum 1983 (NAD 83), South Central Zone):

Beginning at a 1/2-inch iron rod found the southeast corner of a called of a called 4.0174-acre tract of land recorded in the name of Good Shepherd Lutheran Church in Volume 288, Page 254 of the Deed Records of Brazoria County (D.R.B.C.) and the southwesterly exterior corner of said 154.6-acre tract, and being on the northerly right-of-way line of Henderson Road (80.00 feet wide);

- 1. Thence, with the westerly line of said 154.6-acre tract and the easterly line of said 4.0174-acre tract, North 02 degrees 46 minutes 29 seconds West, a distance of 500.35 feet to a 1/2-inch iron rod inside a 4-inch iron pipe found at an interior corner of said 154.6-acre tract and the northeast corner of said 4.0174-acre tract;
- 2. Thence, with a southerly line of said 154.6-acre tract and the northerly line of said 4.0174-acre tract, South 87 degrees 07 minutes 32 seconds West, a distance of 350.09 feet to a easterly line of a called 9.032-acre tract of land recorded in the name of Angleton Drainage District in Volume 329, Page 340 of the D.R.B.C.;
- 3. Thence, with the westerly line of said 154.6-acre tract and said easterly line of the 9.032-acre tract, North 02 degrees 53 minutes 17 seconds West, a distance of 1,157.44 feet to the southwest corner of Reserve "M" of Windrose Green Sec 1, a subdivision recorded in Plat Number 2021062480 of the Brazoria County Plat Records;

Thence, with the south line of said Reserve "M", the following eleven (11) courses:

- 1. North 87 degrees 09 minutes 48 seconds East, a distance of 658.12 feet;
- 2. South 81 degrees 53 minutes 56 seconds East, a distance of 196.45 feet;
- 3. South 83 degrees 12 minutes 15 seconds East, a distance of 78.77 feet;
- 4. South 88 degrees 16 minutes 59 seconds East, a distance of 78.13 feet;
- 5. North 86 degrees 25 minutes 02 seconds East, a distance of 78.13 feet;
- 6. North 81 degrees 27 minutes 27 seconds East, a distance of 78.15 feet;
- 7. North 70 degrees 38 minutes 37 seconds East, a distance of 72.88 feet;
- 8. North 44 degrees 06 minutes 33 seconds East, a distance of 69.78 feet;
- 9. North 21 degrees 44 minutes 36 seconds East, a distance of 32.57 feet;
- 10. North 62 degrees 31 minutes 20 seconds East, a distance of 15.14 feet;
- 11. South 76 degrees 41 minutes 55 seconds East, a distance of 115.00 feet to a east line of said Reserve "M";
- 12. Thence, with a east line of said Reserve "M", 31.77 feet along the arc of a curve to the left, said curve having a central angle of 06 degrees 44 minutes 33 seconds, a radius of 270.00 feet and a chord that bears North 09 degrees 55 minutes 49 seconds East, a distance of 31.75 feet;
- 13. Thence, continuing with said east line of Reserve "M", 19.31 feet along the arc of a curve to the left, said curve having a central angle of 00 degrees 37 minutes 30 seconds, a radius of 1,770.00 feet and a chord that bears North 06 degrees 14 minutes 47 seconds East, a distance of 19.31 feet to the southeast corner of Reserve "K" of aforesaid Windrose Green Sec 1, same being the south terminus of Windrose Bend (60' wide) of aforesaid Windrose Green Sec 1;
- 14. Thence, with the south terminus of said Windrose Bend, South 84 degrees 03 minutes 57 seconds East, a distance of 60.00 feet to the west line of Reserve "D" of aforesaid Windrose Green Sec 1;
- 15. Thence, with the west line of said Reserve "D", 19.96 feet along the arc of a curve to the right, said curve having a central angle of 00 degrees 37 minutes 30 seconds, a radius of 1,830.00 feet and a chord that bears South 06 degrees 14 minutes 47 seconds West, a distance of 19.96 feet;
- 16. 84.26 feet along the arc of a curve to the right, to the southwest corner of Reserve "D", totaling a distance of 179.28 feet, through aforesaid 154.6-acre tract, said curve having a central angle of 31 degrees 07 minutes 38 seconds, a radius of 330.00 feet and a chord that bears South 22 degrees 07 minutes 21 seconds West, a distance of 177.08 feet;

Thence, through said 154.6-acre tract, the following seven (7) courses:

- 1. 44.15 feet along the arc of a curve to the left, said curve having a central angle of 101 degrees 11 minutes 11 seconds, a radius of 25.00 feet and a chord that bears South 12 degrees 54 minutes 25 seconds East, a distance of 38.63 feet;
- 2. South 26 degrees 29 minutes 59 seconds West, a distance of 60.00 feet;
- 3. 37.53 feet along the arc of a curve to the right, said curve having a central angle of 06 degrees 30 minutes 57 seconds, a radius of 330.00 feet and a chord that bears North 60 degrees 14 minutes 32 seconds West, a distance of 37.51 feet;
- 4. 29.10 feet along the arc of a curve to the left, said curve having a central angle of 66 degrees 41 minutes 16 seconds, a radius of 25.00 feet and a chord that bears South 89 degrees 40 minutes 19 seconds West, a distance of 27.48 feet;
- 5. 100.13 feet along the arc of a curve to the right, said curve having a central angle of 17 degrees 23 minutes 09 seconds, a radius of 330.00 feet and a chord that bears South 65 degrees 01 minutes 15 seconds West, a distance of 99.75 feet;
- 6. South 22 degrees 25 minutes 04 seconds East, a distance of 160.17 feet;
- 7. South 02 degrees 47 minutes 14 seconds East, a distance of 15.00 feet to a southerly line of aforesaid 154.6-acre tract and the northerly line of a called 12.40-acre tract of land recorded in the name of Wesley Johnson in File No. 02 052985 of the O.P.R.B.C.;
- 8. Thence, with the common line of said 154.6-acre tract and said 12.40-acre tract, South 87 degrees 12 minutes 46 seconds West, a distance of 241.63 feet to a 3/4-inch iron pipe found at an interior corner of said 154.6-acre tract, the northwest corner of said 12.40-acre tract, and the northeast corner of a called 14.571-acre tract of land recorded in the name of E. J. King, Sr. and Jackie M. King in File No. 2014054480 of the O.P.R.B.C.;
- 9. Thence, continuing with said southerly line of the 154.6-acre tract and with the northerly line of said 14.571-acre tract, South 87 degrees 15 minutes 57 seconds West, a distance of 499.89 feet to a 5/8-inch iron rod found at the northwest corner of said 14.571-acre tract;
- 10. Thence, with an easterly line of said 154.6-acre tract and the westerly line of said 14.571-acre tract, South 02 degrees 45 minutes 27 seconds East, a distance of 1,271.10 feet to a 5/8-inch iron rod found on the northerly right-of-way line of aforesaid Henderson Road;
- 11. Thence, with the southerly line of said 154.6-acre tract and said northerly right-of-way line of Henderson Road, South 87 degrees 06 minutes 09 seconds West, a distance of 198.28 feet to the Point of Beginning and containing 23.70 acres of land.

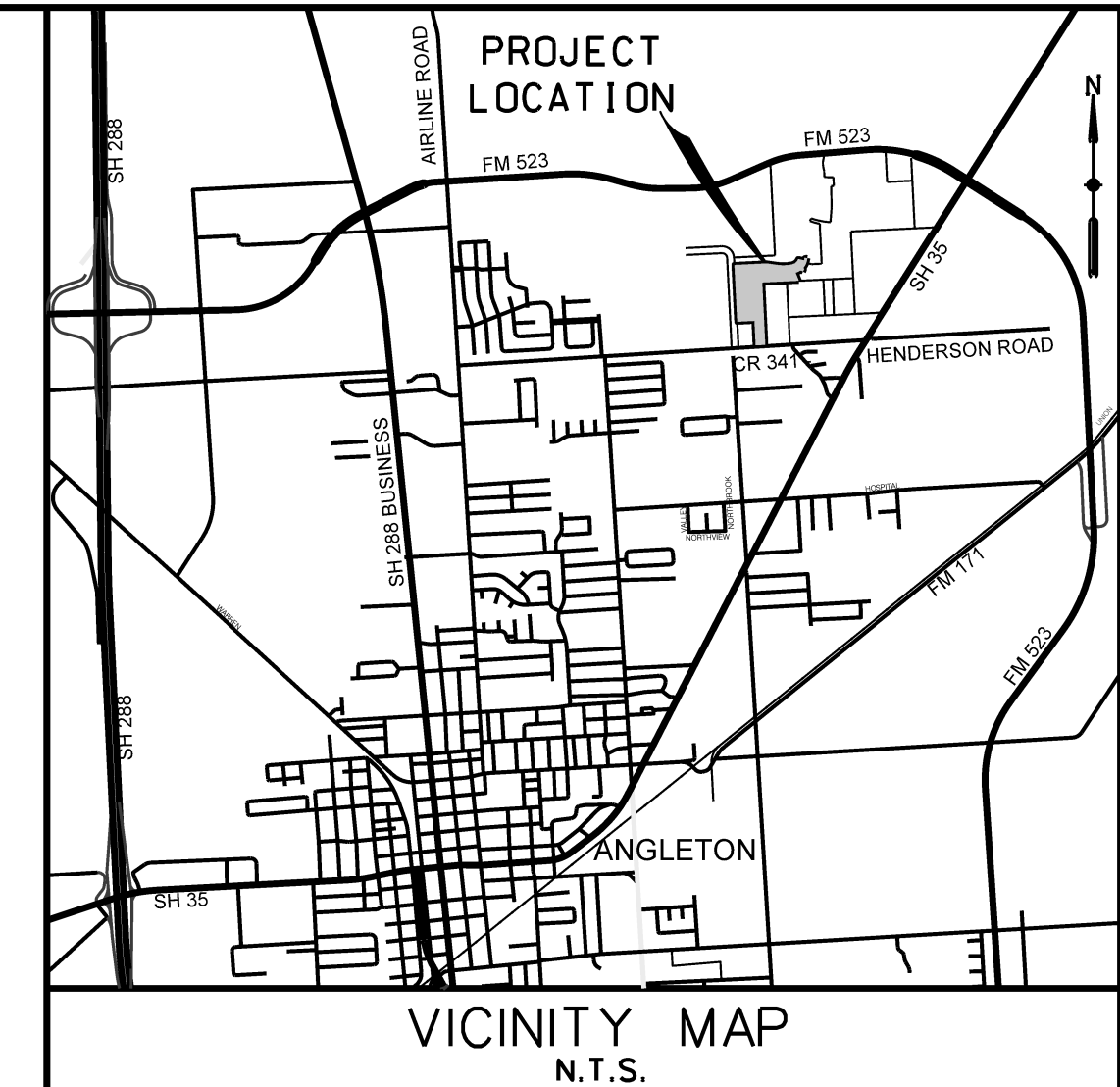

NOTICE: SELLING A PORTION OF THIS ADDITION BY METES AND BOUNDS IS A VIOLATION OF THE UNIFIED DEVELOPMENT CODE OF THE CITY OF ANGLETON AND STATE PLATTING STATUTES AND IS SUBJECT TO FINES AND WITHHOLDING OF UTILITIES AND BUILDING PERMITS.

NOTICE: PLAT APPROVAL SHALL NOT BE DEEMED TO OR PRESUMED TO GIVE AUTHORITY TO VIOLATE, NULLIFY, VOID, OR CANCEL ANY PROVISIONS OF LOCAL, STATE, OR FEDERAL LAWS, ORDINANCES, OR CODES.

NOTICE: THE APPLICANT IS RESPONSIBLE FOR SECURING ANY FEDERAL PERMITS THAT MAY BE NECESSARY AS THE RESULT OF PROPOSED DEVELOPMENT ACTIVITY. THE CITY OF ANGLETON IS NOT RESPONSIBLE FOR DETERMINING THE NEED FOR, OR ENSURING COMPLIANCE WITH ANY FEDERAL PERMIT."

NOTICE: APPROVAL OF THIS PLAT DOES NOT CONSTITUTE A VERIFICATION OF ALL DATA, INFORMATION AND CALCULATIONS SUPPLIED BY THE APPLICANT. THE ENGINEER OF RECORD OR REGISTERED PUBLIC LAND SURVEYOR IS SOLELY RESPONSIBLE FOR THE COMPLETENESS, ACCURACY AND ADEQUACY OF HIS/HER SUBMITTAL WHETHER OR NOT THE APPLICATION IS REVIEWED FOR CODE COMPLIANCE BY THE CITY ENGINEER.

NOTICE: ALL RESPONSIBILITY FOR THE ADEQUACY OF THIS PLAT REMAINS WITH THE ENGINEER OR SURVEYOR WHO PREPARED THEM. IN APPROVING THESE PLANS, THE CITY OF ANGLETON MUST RELY ON THE ADEQUACY OF THE WORK OF THE ENGINEER AND/OR SURVEYOR OF RECORD.

Provide the required plat notes take from the Angleton LDC Sec. 23-115, L.

Remove additional text shown in the Engineer's Certification Block

FINAL PLAT OF
WINDROSE GREEN
SECTION THREE

BEING 23.70 ACRES

LOCATED IN THE
T. S. LEE SURVEY, A-318
BRAZORIA COUNTY, TEXAS

122 LOTS 3 BLOCKS 4 RESERVES

JANUARY, 2023

ENGINEER/SURVEYOR:

Costello

OWNER:

EMPTOR ANGLETON, LLC.,
A TEXAS LIMITED LIABILITY COMPANY



COSTELLO, INC.
2107 CITYWEST BOULEVARD
3RD FLOOR
HOUSTON, TEXAS 77042
(713) 783-7788 FAX: 783-3580
TBPE FIRM REGISTRATION NO. 280
TBPLS FIRM REGISTRATION NO. 100486

9950 WESTPARK DR. #285
HOUSTON, TEXAS 77063

PLANNER:
META
PLANNING + DESIGN
24275 KATY FREEWAY, SUITE 200
KATY, TEXAS 77494
Tel: 281-810-1422

FILED

CALLED 100.000 ACRES
 ANGLETON INDEPENDENT
 SCHOOL DISTRICT
 FILE NO. 2008002676
 O.P.R.B.C.

WINDROSE GREEN
 SEC 1
 PLAT NO. 2021062480
 B.C.P.R.

WINDROSE GREEN
 SEC 1
 PLAT NO.
 2021062480
 B.C.P.R.

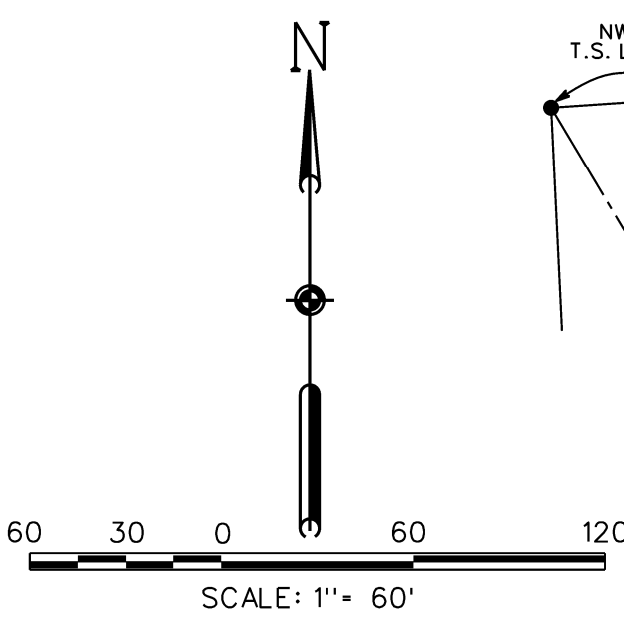

LEGEND

- SET 5/8 - INCH IRON ROD WITH PLASTIC CAP STAMPED "COSTELLO INC" UNLESS OTHERWISE NOTED
- ⊙ - FOUND 5/8 - INCH IRON ROD UNLESS OTHERWISE NOTED
- ① - INDICATES BLOCK NUMBER
- Ⓐ - INDICATES RESERVE
- - INDICATES STREET NAME BREAK

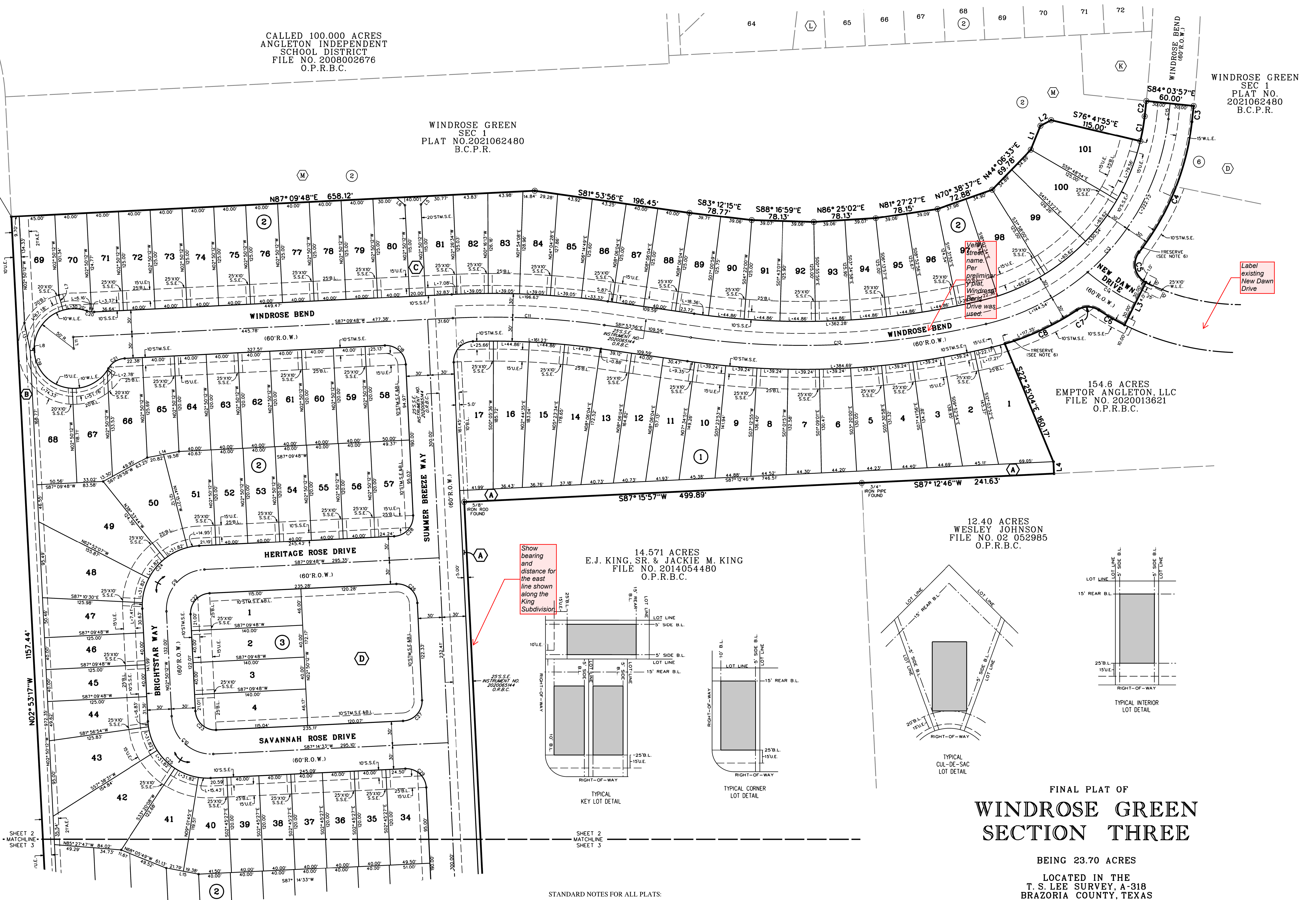

RESERVE "A"
 HERITAGE PARK
 SUBDIVISION
 SECTION NO. 2
 DOCUMENT NO. 2017045765
 O.P.R.B.C.

9.032 ACRES
 ANGLETON DRAINAGE DISTRICT
 VOL. 329, PG. 340 D.R.B.C.

154.6 ACRES
 EMPTOR ANGLETON, LLC
 FILE NO. 2020013621
 O.P.R.B.C.

14.571 ACRES
 E.J. KING, SR. & JACKIE M. KING
 FILE NO. 2014054480
 O.P.R.B.C.

12.40 ACRES
 WESLEY JOHNSON
 FILE NO. 02 052985
 O.P.R.B.C.

- GENERAL NOTES:
- ALL BEARINGS ARE REFERENCED TO THE TEXAS COORDINATE SYSTEM (NAD83, 1993 ADJ.) SOUTH CENTRAL ZONE.
 - ALL EASEMENTS SHOWN ON LOT LINES ARE CENTERED UNLESS OTHERWISE NOTED.
 - EASEMENTS ARE HEREBY RESERVED AS SHOWN TO FACILITATE ROADWAYS, DRAINAGE, AND INSTALLATION OF UTILITIES, INCLUDING BUT NOT LIMITED TO ELECTRICAL LINES, WASTEWATER DISPOSAL LINES, GAS, AND WATER LINES. THERE IS ALSO A RESERVED TEN (10) FOOT STRIP CENTERED ALONG ALL TRACT LINES FOR A GENERAL DRAINAGE AND UTILITY EASEMENT.
 - ALL RESERVES SHALL BE OWNED AND MAINTAINED BY HOMEOWNER'S ASSOCIATION OR MUD.
 - ALL DRAINAGE EASEMENTS SHOWN HEREON SHALL BE DEDICATED TO THE PUBLIC AND SHALL BE MAINTAINED BY THE RANCHO ISABELLA MUNICIPAL UTILITY DISTRICT.
 - A ONE-FOOT RESERVE DEDICATED TO THE PUBLIC IN FEE AS A BUFFER SEPARATION BETWEEN THE SIDE OR END OF STREETS WHERE SUCH STREETS ADJACENT PROPERTY. THE CONDITIONS OF THIS DEDICATION BEING THAT WHEN THE ADJACENT PROPERTY IS SUBDIVIDED OR RE-SUBDIVIDED IN A RECORDED PLAT, THE ONE-FOOT RESERVE SHALL THEREUPON BECOME VESTED IN THE PUBLIC FOR STREET RIGHT-OF-WAY PURPOSES AND THE FEE TITLE THERETO SHALL REVERT TO AND REVEST IN THE DEDICATOR, HIS HEIRS, ASSIGNS, OR SUCCESSORS.
 - HORIZONTAL DATUM:
 ALL BEARINGS ARE REFERENCED TO THE TEXAS COORDINATE SYSTEM, NORTH AMERICAN DATUM OF 1983 (NAD83), SOUTH CENTRAL ZONE.
 VERTICAL DATUM:
 ALL ELEVATIONS ARE REFERENCED TO THE NORTH AMERICAN VERTICAL DATUM OF 1988 (NAVD88), GEOID 12B, BASED ON ALLTERRA'S RTK NETWORK STATIONS HAGS_1012 AND HC0G_14012.
 ACCORDING TO THE NATIONAL FLOOD INSURANCE PROGRAM FLOOD INSURANCE RATE MAP FOR BRAZORIA COUNTY, TEXAS, MAP NUMBER 48039C0435 H, DATED JUNE 5, 1989 THIS PROPERTY LIES IN UNSHADDED ZONE "X", WHICH IS DEFINED AS AREAS DETERMINED TO BE OUTSIDE THE 500-YEAR FLOODPLAIN.
 - NO PIPELINE OR PIPELINE EASEMENT EXISTS WITHIN THE BOUNDARIES OF THIS PLAT.
 - SIDEWALKS SHALL BE CONSTRUCTED IN ACCORDANCE TO THE DEVELOPMENT AGREEMENT BETWEEN THE CITY OF ANGLETON, TEXAS AND OWNER.
 - RESERVES "A", "B", "C" AND "D" WILL BE OWNED AND MAINTAINED BY THE RANCHO ISABELLA MUNICIPAL UTILITY DISTRICT.
 - RESERVE "D" WILL BE OWNED AND MAINTAINED BY THE HOMEOWNER'S ASSOCIATION.

WINDROSE GREEN SECTION THREE RESERVE TABLE

DESCRIPTION	LAND USE	ACREAGE/SQUARE FOOTAGE
RESERVE "A"	LANDSCAPE / OPEN SPACE / DRAINAGE	0.40 AC. / 17,361 50 FT.
RESERVE "B"	LANDSCAPE / OPEN SPACE / DRAINAGE	0.76 AC. / 33,046 50 FT.
RESERVE "C"	LANDSCAPE / OPEN SPACE / DRAINAGE	0.06 AC. / 26,000 50 FT.
RESERVE "D"	PARK	0.57 AC. / 24,743 50 FT.
TOTAL:		1.79 AC. / 101,150 50 FT.

ABBREVIATION TABLE

O.P.R.B.C.	OFFICIAL PUBLIC RECORDS OF BRAZORIA COUNTY
D.R.B.C.	DEED RECORDS BRAZORIA COUNTY
B.C.P.R.	BRAZORIA COUNTY PLAT RECORDS
C.F. NO.	CLERK'S FILE NUMBER
A.E.	AERIAL EASEMENT
U.E.	UTILITY EASEMENT
S.S.E.	SANITARY SEWER EASEMENT
STM.S.E.	STORM SEWER EASEMENT
W.L.E.	WATER LINE EASEMENT
D.E.	DRAINAGE EASEMENT
ESMT.	EASEMENT
B.L.	BUILDING LINE
R.O.W.	RIGHT-OF-WAY
P.O.B.	POINT OF BEGINNING

STANDARD NOTES FOR ALL PLATS:

NOTICE: SELLING A PORTION OF THIS ADDITION BY METES AND BOUNDS IS A VIOLATION OF THE UNIFIED DEVELOPMENT CODE OF THE CITY OF ANGLETON AND STATE PLATING STATUTES AND IS SUBJECT TO FINES AND WITHHOLDING OF UTILITIES AND BUILDING PERMITS.

NOTICE: PLAT APPROVAL SHALL NOT BE DEEMED TO OR PRESUMED TO GIVE AUTHORITY TO VIOLATE, NULLIFY, VOID, OR CANCEL ANY PROVISIONS OF LOCAL, STATE, OR FEDERAL LAWS, ORDINANCES, OR CODES.

NOTICE: THE APPLICANT IS RESPONSIBLE FOR SECURING ANY FEDERAL PERMITS THAT MAY BE NECESSARY AS THE RESULT OF PROPOSED DEVELOPMENT ACTIVITY. THE CITY OF ANGLETON IS NOT RESPONSIBLE FOR DETERMINING THE NEED FOR, OR ENSURING COMPLIANCE WITH ANY FEDERAL PERMIT.

NOTICE: APPROVAL OF THIS PLAT DOES NOT CONSTITUTE A VERIFICATION OF ALL DATA, INFORMATION AND CALCULATIONS SUPPLIED BY THE APPLICANT. THE ENGINEER OF RECORD OR REGISTERED PUBLIC LAND SURVEYOR IS SOLELY RESPONSIBLE FOR THE COMPLETENESS, ACCURACY AND ADEQUACY OF HIS/HER SUBMITTAL WHETHER OR NOT THE APPLICATION IS REVIEWED FOR CODE COMPLIANCE BY THE CITY ENGINEER.

NOTICE: ALL RESPONSIBILITY FOR THE ADEQUACY OF THIS PLAT REMAINS WITH THE ENGINEER OR SURVEYOR WHO PREPARED THEM. IN APPROVING THESE PLANS, THE CITY OF ANGLETON MUST RELY ON THE ADEQUACY OF THE WORK OF THE ENGINEER AND/OR SURVEYOR OF RECORD.

Show bearing and distance for the east line shown along the King Subdivision

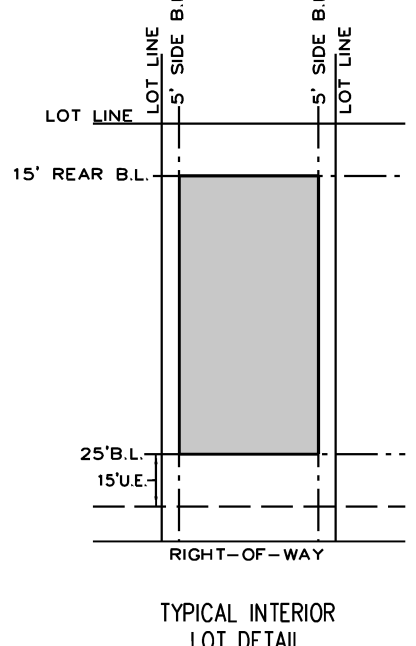
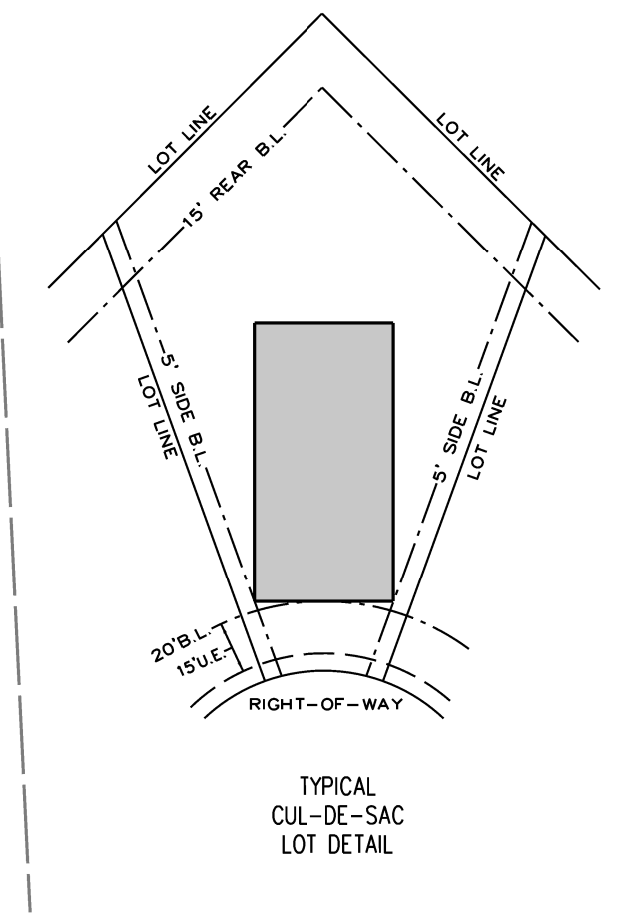
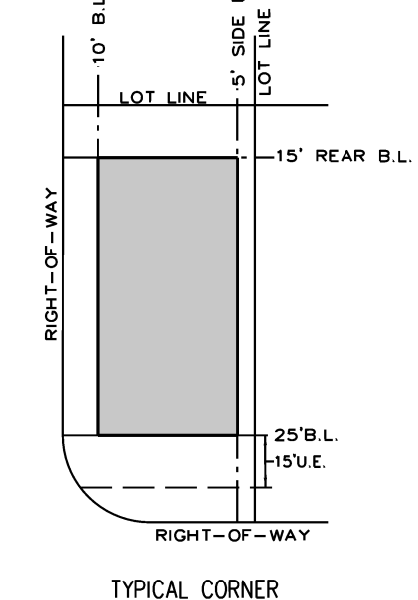
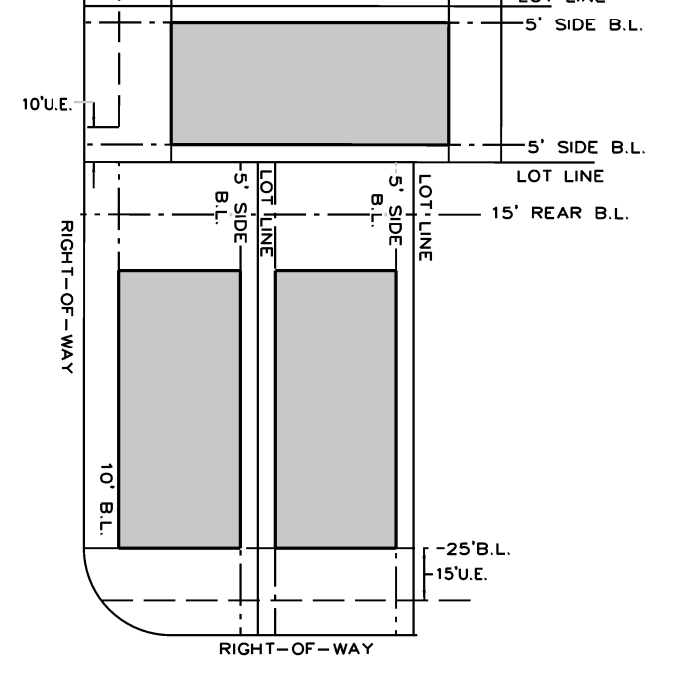

FINAL PLAT OF
WINDROSE GREEN SECTION THREE

BEING 23.70 ACRES
 LOCATED IN THE
 T. S. LEE SURVEY, A-318
 BRAZORIA COUNTY, TEXAS
 122 LOTS 3 BLOCKS 4 RESERVES

SCALE: 1" = 60' JANUARY, 2023

PLANNER:
META
 PLANNING + DESIGN
 24275 KATY FREEWAY, SUITE 200
 KATY, TEXAS 77494
 Tel: 281-810-1422

OWNER:
EMPTOR ANGLETON, LLC,
 A TEXAS LIMITED LIABILITY COMPANY
 9950 WESTPARK DR. #285
 HOUSTON, TEXAS 77063

ENGINEER/SURVEYOR:
Costello
 COSTELLO, INC.
 2107 CITYWEST BOULEVARD
 3RD FLOOR
 HOUSTON, TEXAS 77042
 (713) 783-7788 FAX: 783-3580
 TPBE FIRM REGISTRATION NO. 280
 TPBLS FIRM REGISTRATION NO. 100486

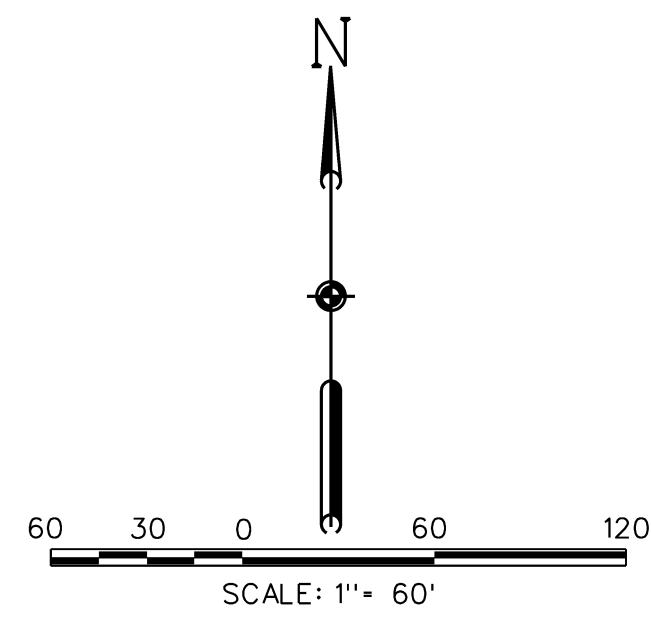

LEGEND

- SET 5/8 - INCH IRON ROD WITH PLASTIC CAP STAMPED "COSTELLO INC" UNLESS OTHERWISE NOTED
- ⊙ - FOUND 5/8 - INCH IRON ROD UNLESS OTHERWISE NOTED
- ① - INDICATES BLOCK NUMBER
- A - INDICATES RESERVE
- - - INDICATES STREET NAME BREAK

ABBREVIATION TABLE	
D.P.R.B.C.	OFFICIAL PUBLIC RECORDS OF BRAZORIA COUNTY
D.R.B.C.	DEED RECORDS BRAZORIA COUNTY
B.C.P.R.	BRAZORIA COUNTY PLAT RECORDS
C.F. NO.	CLERK'S FILE NUMBER
A.E.	AERIAL EASEMENT
U.E.	UTILITY EASEMENT
S.S.E.	SANITARY SEWER EASEMENT
STM.S.E.	STORM SEWER EASEMENT
W.L.E.	WATER LINE EASEMENT
D.E.	DRAINAGE EASEMENT
ESMT.	EASEMENT
B.L.L.	BUILDING LINE
R.O.W.	RIGHT-OF-WAY
P.O.B.	POINT OF BEGINNING

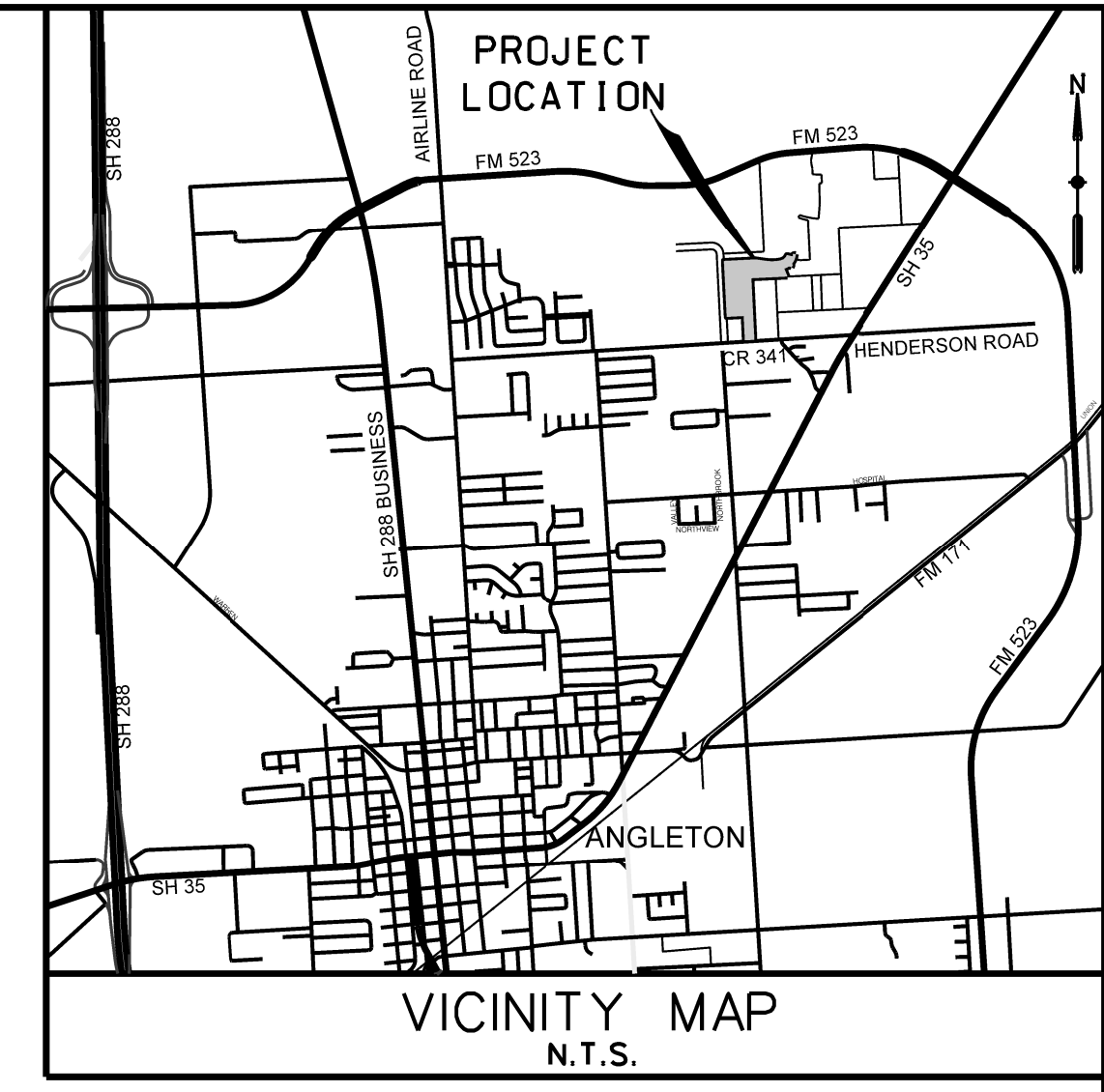

RESERVE "A"
HERITAGE PARK
SUBDIVISION
SECTION NO. 2
DOCUMENT NO. 2017045765
O.P.R.B.C.

WINDROSE GREEN SECTION THREE RESERVE TABLE		
DESCRIPTION	LAND USE	ACREAGE/SQUARE FOOTAGE
RESERVE "A"	LANDSCAPE / OPEN SPACE / DRAINAGE	0.40 AC. / 17,361 SQ. FT.
RESERVE "B"	LANDSCAPE / OPEN SPACE / DRAINAGE	0.76 AC. / 33,046 SQ. FT.
RESERVE "C"	LANDSCAPE / OPEN SPACE / DRAINAGE	0.06 AC. / 26,000 SQ. FT.
RESERVE "D"	PARK	0.57 AC. / 24,743 SQ. FT.
TOTAL:		1.79 AC. / 101,150 SQ. FT.

LINE DATA TABLE

NUMBER	DIRECTION	DISTANCE (FEET)
L1	N21°44'36"E	32.57
L2	N62°31'20"E	19.96
L3	S26°29'59"W	60.00
L4	S02°47'14"E	15.00
L5	N42°09'48"E	14.14
L6	N47°50'12"W	14.14
L7	S15°35'32"E	20.00
L8	N87°25'20"E	4.99
L9	S87°07'20"W	5.02
L10	N47°45'27"W	14.14
L11	S02°50'12"E	14.61
L12	N02°45'27"W	15.00
L13	N11°42'23"W	35.46
L14	N79°04'05"E	40.40
L15	N79°03'05"W	41.17

CURVE DATA TABLE

NUMBER	ARC LENGTH (FEET)	RADIUS (FEET)	DELTA ANGLE	CHORD DIRECTION	CHORD LENGTH (FEET)
C1	31.77	270.00	6° 44' 33"	N09° 55' 49" E	31.75
C2	19.31	1770.00	0° 37' 30"	N06° 14' 47" E	19.31
C3	19.96	1830.00	0° 37' 30"	S06° 14' 47" W	19.96
C4	179.28	330.00	31° 7' 38"	S22° 07' 23" W	177.08
C5	44.15	25.00	101° 11' 11"	S12° 54' 25" E	38.63
C6	37.53	330.00	6° 30' 57"	N60° 14' 32" W	37.51
C7	29.10	25.00	66° 41' 16"	S89° 40' 19" W	27.48
C8	100.13	330.00	17° 23' 9"	S65° 01' 15" W	99.75
C9	78.54	50.00	90° 0' 0"	N42° 09' 48" E	70.71
C10	78.47	50.00	89° 55' 15"	S47° 47' 50" E	70.66
C11	180.90	1000.00	10° 56' 16"	S87° 22' 04" E	190.61
C12	373.48	1000.00	21° 23' 56"	N87° 24' 06" E	371.32
C13	367.27	300.00	70° 8' 35"	N41° 37' 50" E	344.76
C14	71.98	300.00	13° 44' 7"	S56° 37' 37" E	71.80
C15	19.63	1800.00	0° 37' 30"	N06° 14' 47" E	19.63
C16	16.09	25.00	36° 52' 11"	S21° 11' 33" E	15.81
C17	39.85	25.00	91° 20' 7"	S42° 54' 37" W	35.76
C18	39.30	25.00	90° 4' 45"	N47° 47' 50" E	35.38
C19	226.25	50.00	258° 15' 58"	S20° 37' 23" E	77.01
C20	9.53	25.00	21° 50' 48"	S81° 54' 48" E	9.47
C21	25.05	25.00	57° 25' 10"	N58° 27' 13" E	24.02
C22	39.27	25.00	90° 0' 0"	S42° 09' 48" W	35.36
C23	39.24	25.00	89° 55' 15"	S47° 47' 50" E	35.33
C24	117.81	75.00	90° 0' 0"	S47° 09' 48" W	105.07
C25	117.71	75.00	89° 55' 15"	S47° 47' 50" E	105.99
C26	39.30	25.00	90° 4' 45"	S47° 47' 50" E	35.38
C27	39.27	25.00	90° 0' 0"	N42° 14' 33" E	35.36
C28	39.24	25.00	89° 55' 15"	N42° 12' 10" E	35.33
C29	39.27	25.00	90° 0' 0"	S47° 45' 27" E	35.36
C30	225.85	50.00	258° 48' 31"	S15° 36' 26" W	77.27
C31	25.21	25.00	57° 46' 9"	S63° 52' 23" E	24.15
C32	9.18	25.00	21° 2' 22"	N76° 43' 22" E	9.13
C33	39.27	25.00	90° 0' 0"	N42° 14' 33" E	35.36
C34	39.27	25.00	90° 0' 0"	S47° 45' 27" E	35.36
C35	39.21	25.00	89° 51' 36"	S42° 10' 21" W	35.31

9.032 ACRES
ANGLETON DRAINAGE DISTRICT
VOL.329, PG.340 D.R.B.C.

4.0174 ACRES
GOOD SHEPHERD
LUTHERAN CHURCH
VOL. 288, PG 254
O.P.R.B.C.

14.571 ACRES
E.J. KING SR. & JACKIE M. KING
FILE NO. 2014054480
O.P.R.B.C.

FINAL PLAT OF
WINDROSE GREEN SECTION THREE
BEING 23.70 ACRES
LOCATED IN THE
T. S. LEE SURVEY, A-318
BRAZORIA COUNTY, TEXAS
122 LOTS 3 BLOCKS 4 RESERVES

SCALE: 1" = 60' JANUARY, 2023

PLANNER:
META
PLANNING + DESIGN
24275 KATY FREEWAY, SUITE 200
KATY, TEXAS 77494
Tel: 281-810-1422

OWNER:
EMPTOR ANGLETON, LLC.,
A TEXAS LIMITED LIABILITY COMPANY

ENGINEER/SURVEYOR:
Costello
COSTELLO, INC.
2107 CITYWEST BOULEVARD
3RD FLOOR
HOUSTON, TEXAS 77042
(713) 783-7788 FAX: 783-3580
TBPE FIRM REGISTRATION NO. 280
TBPLS FIRM REGISTRATION NO. 100486